

ERCHONIA® FX-635™

**A double-blind, placebo-controlled
randomized evaluation of the effect
of the Erchonia® FX-635™
on diabetic peripheral neuropathy pain
clinical study protocol**

ERCHONIA CORPORATION

**Version 1.1
January 12, 2016**

TABLE OF CONTENTS

Contents

STUDY INFORMATION..... 1
SPONSOR..... 1
REGULATORY CONSULTANT 1
CLINICAL CONSULTANT 1
MONITORS 1
PRINCIPAL CLINICAL INVESTIGATOR(S) AND TEST SITE(S) 2
PURPOSE OF STUDY 2
INDICATION FOR USE 2
EXPECTED RESULTS 3
STUDY INDICATION, THEORY OF MECHANISM OF OPERATION, STUDY RATIONALE &
SUPPORTING MATERIALS 4
THEORY OF MECHANISM OF OPERATION OF THE APPLICATION OF LOW LEVEL LASER
THERAPY TO REDUCING PAIN..... 10
DEVICE INFORMATION: ERCHONIA® FX-635™ 14
STUDY DESIGN 26
SUBJECT GROUPS 26
WANTED 29
ADULTS WITH DIABETES WITH FOOT PAIN ONGOING OVER THE LAST 3 MONTHS FOR
ACLINICAL STUDY OF THE EFFECTS OF 29
FOR MORE INFORMATION PLEASE CONTACT: 29
STUDY PROCEDURE 31
STUDY TEST BATTERY 31
PRE-PROCEDURE ACTIVITIES 35
STUDY QUALIFICATION 35
PRE-PROCEDURE EVALUATION PHASE 38
PRE-PROCEDURE VARIABLES 38
PROCEDURE ADMINISTRATION PHASE 39
POST-PROCEDURE ACTIVITIES 40
OPEN-LABEL PLACEBO SUBJECT PROCEDURE ADMINISTRATION PERIOD 41
ADVERSE EVENTS 45
PRIVACY AND CONFIDENTIALITY 45
MONITORING OF THE CLINICAL STUDY 45
STATISTICAL ANALYSIS 46
INFORMED CONSENT 51
CASE REPORT FORMS 51

STUDY INFORMATION

SPONSOR

Erchonia Corporation
2021 Commerce Drive
McKinney, TX 75069
Contact: Mr. Steven Shanks, President
Telephone: 214-544-2227
Fax: 214-544-2228
e-mail: sshanks@erchonia.com

REGULATORY CONSULTANT

Regulatory Insight, Inc.
Denver Office
33 Golden Eagle Lane
Littleton, CO 80127
Contact: Kevin Walls, Principal Consultant
Telephone: 720-962-5412
Fax: 720-962-5413
E-mail: kevin@reginsight.com

CLINICAL CONSULTANT

Regulatory Insight, Inc.
Nashville Office
1503 Red Oak Drive
Brentwood, TN 37027
Contact: Elvira Walls, Clinical Consultant
Telephone: 615-712-9743
Fax: 615-712-9852
E-mail: elvira@reginsight.com

MONITORS

🕒 Erchonia Corporation
2021 Commerce Drive
McKinney, TX 75069
Contact: Mr. Joseph Zapolsky
Telephone: 214-544-2227
Fax: 214-544-2228
e-mail: jzapolsky@erchonia.com

🕒 Regulatory Insight, Inc.
Nashville Office
1503 Red Oak Drive
Brentwood TN 37027
Contact: Elvira Walls, Clinical Consultant
Telephone: 615-712-9743
Fax: 615-712-9852
e-mail: Elvira@reginsight.com

PRINCIPAL CLINICAL INVESTIGATOR(S) AND TEST SITE(S)

🕒 Kerry Zang, DPM
Arizona Institute of Footcare Physicians
1620 S. Stapley Dr., Suite 132
Mesa, AZ 85204
Telephone: 480-834-8804
Fax: 480-464-8289
E-mail: kerryzang@aol.com

🕒 Mr. Robert Sullivan
BSc. (Hons) Podiatry, MSc. Pod Surgery,
PgC.Acup, .FICHPA. M.Inst.Ch.P.
Clinical Director
Midleton Foot Clinic
22 New Cork Road,
Midleton,
Co. Cork, Ireland
Telephone: 021-4621044
e-mail: robert.sullivan@midletonfootclinic.ie

INSTITUTIONAL REVIEW BOARD (U.S. TEST SITE)

🕒 Western Institutional Review Board® (WIRB®)
3535 Seventh Avenue, SW
Olympia, WA 98502-5010
United States
Telephone: 360-252-2500
Fax: 360-252-2498

ETHICS COMMITTEE (IRELAND TEST SITE)

🕒 Irish Chiropody and Podiatry Association Ethics Board
2nd Floor
22 New Cork Road
Midleton, Co. Cork
Ireland

PURPOSE OF STUDY

The purpose of this clinical study is to determine the effectiveness of the Erchonia® FX-635™, manufactured by Erchonia Corporation (the Company), in providing relief of foot pain in individuals with chronic painful diabetic peripheral neuropathy.

INDICATION FOR USE

The indication (claim) being sought through support of the results of this clinical study is: "The Erchonia® FX-635™ is indicated for adjunctive use in providing relief of chronic pain arising from diabetic peripheral neuropathy."

It is intended that the results of this clinical study be used to support a 510(k) submission to FDA for clearance to market the device for the intended indication.

EXPECTED RESULTS

Following completion of the study procedure protocol with the Erchonia® FX-635™ relative to baseline, it is anticipated that significantly more subjects in the test group than in the placebo group will show a 30% or greater reduction in self-reported VAS pain rating in the feet.

RESOURCES

This clinical study protocol design and content is based on the clinical study protocols whose implementation outcome was used to successfully support FDA clearances to market the Erchonia® EML low level laser for the following chronic pain reduction related indications:

- 🕒 *K132940: Erchonia® Allay™*: is indicated as an adjunct to reducing chronic heel pain arising from plantar fasciitis.
- 🕒 *K050672: Erchonia EVRL Laser*: is generally indicated while using the red diode, for adjunctive use in providing temporary relief of minor chronic neck and shoulder pain of musculoskeletal origin.

STUDY INDICATION, THEORY OF MECHANISM OF OPERATION, STUDY RATIONALE & SUPPORTING MATERIALS

STUDY INDICATION: CHRONIC PAINFUL DIABETIC PERIPHERAL NEUROPATHY

The study indication to be evaluated in this study is the temporary relief of chronic foot pain arising from diabetic peripheral neuropathy.

STATISTICS

Peripheral neuropathy is one of the most common chronic diseases and a leading cause of adult disability in the U.S. Of the over 100 known types of neuropathy, diabetic neuropathy represents over a third of all neuropathies, making diabetes the leading cause of peripheral neuropathy. Due to the increasing prevalence of diabetes, there are now about 15-18 million Americans with diabetic peripheral neuropathy, about 60% to 70% of the 25.8 million adults and children in the U.S. with diabetes. U.S. (Source: *The Neuropathy Association*). In addition, there are 79 million individuals in the U.S. with pre-diabetes who are at risk for developing diabetic peripheral neuropathy (Source: *The Center for Disease Control*).

Living with neuropathy can cause tremendous frustration and social isolation for patients. The daily chronic pain impacts day-to-day functionality resulting in physical and psychological problems including impaired concentration, anxiety, depression, a decline in cognitive abilities, and sleep difficulties which in turn can lead to irritability and increased pain sensitivity. Additionally, the economic burden from medical costs and workplace productivity losses are high and on the rise as the incidence of peripheral neuropathy increases. Neuropathic pain patients are often high health care system users as they seek relief from persistent suffering. Those debilitated by neuropathy or coping with chronic pain are challenged with working full-time, and may become unemployable or stay under-employed.

DESCRIPTION & DEFINITION

Peripheral neuropathy describes damage to the peripheral nervous system, the vast communications network that transmits information from the brain and spinal cord (central nervous system) to every other part of the body. Peripheral nerves also send sensory information back to the brain and spinal cord, such as a message that the feet are cold or a finger is burned. Damage to the peripheral nervous system interferes with these vital connections, distorting and sometimes interrupting messages between the brain and the rest of the body.

🕒 Classification of the Peripheral Neuropathies

More than 100 types of peripheral neuropathy have been identified, each with its own characteristic set of symptoms, pattern of development and prognosis. Specific impaired function and symptoms depend on the type of nerves - motor, sensory, or autonomic - that are damaged:

- *Motor nerves* control movements of all muscles under conscious control, such as those used for walking, grasping things, or talking
- *Sensory nerves* transmit information about sensory experiences, such as the feeling of a light touch or the pain resulting from a cut.
- *Autonomic nerves* regulate biological activities that people do not control consciously, such as breathing, digesting food, and heart and gland functions.

🕒 Forms of Neuropathy

- *Mononeuropathies*: Neuropathies that involve damage to only one nerve.
- *Polyneuropathies*: Neuropathies that involve multiple nerves affecting all limbs.
- *Mononeuritis multiplex*: Less commonly, neuropathies wherein two or more isolated nerves in separate areas of the body are affected

Some neuropathies affect all three types of nerves, but most often, neuropathies primarily affect one or two types. Therefore, neuropathies may be further described as predominantly motor neuropathy, predominantly sensory neuropathy, sensory-motor neuropathy, or autonomic neuropathy.

🕒 Acute versus Chronic Neuropathies

In *acute neuropathies*, such as Guillain-Barre syndrome, symptoms appear suddenly, progress rapidly, and resolve slowly as damaged nerves heal.

In *chronic neuropathies*, symptoms begin subtly and progress slowly. There may be periods of relief followed by relapse. A plateau stage may be reached where symptoms stay the same for months or years. Some chronic neuropathies worsen over time, but fatality from neuropathy is extremely rare unless complicated by other diseases. Occasionally, neuropathy is a symptom of another disorder.

🕒 Acquired peripheral neuropathies

Peripheral neuropathy may be either acquired or inherited.

🕒 Acquired vs. inherited peripheral neuropathies

- *Acquired peripheral neuropathies* are grouped into three broad categories; those caused by:
 - ✓ *systemic disease*
 - ✓ *trauma from external agents*
 - ✓ *infections or autoimmune disorders affecting nerve tissue*

Causes of *acquired peripheral neuropathy* include:

- ✓ physical injury (trauma) to a nerve
 - ✓ tumors
 - ✓ toxins
 - ✓ autoimmune responses
 - ✓ nutritional deficiencies
 - ✓ alcoholism
 - ✓ vascular and metabolic disorders
- *Inherited forms of peripheral neuropathy* are caused by inborn mistakes in the genetic code or by new genetic mutations. Depending on the genetic error/mutation, inherited peripheral neuropathies can range from those with symptoms that begin in early adulthood and are minimal to more severe forms and symptoms/impairments that may begin in infancy or childhood. The most common inherited neuropathies are a group of disorders collectively referred to as *Charcot-Marie-Tooth disease* that result from flaws in genes responsible for

manufacturing neurons or the myelin sheath and are characterized by extreme weakening and wasting of muscles in the lower legs and feet, gait abnormalities, loss of tendon reflexes, and numbness in the lower limbs.

🕒 Diabetic Peripheral Neuropathy

Diabetic peripheral neuropathy is a chronic acquired form of nerve damage that can occur in individuals with diabetes. High blood sugar can injure nerve fibers throughout the body, but diabetic neuropathy most often damages nerves in the legs and feet.

ETIOLOGY

The primary cause of diabetic peripheral neuropathy is damage to nerve fibers and blood vessels from prolonged exposure to high blood sugar (glucose). While the precise mechanism for this damage remains unclear, a combination of factors likely plays a role, including the complex interaction between nerves and blood vessels. High blood glucose interferes with the ability of the nerves to transmit signals and weakens the walls of the small blood vessels (capillaries) that supply the nerves with oxygen and nutrients.

Other factors that may contribute to diabetic neuropathy include:

- *Inflammation in the nerves* caused by an autoimmune response that occurs when the immune system mistakenly attacks part of the body as if it were a foreign organism.
- Genetic factors unrelated to diabetes that make some people more susceptible to nerve damage.
- *Smoking and alcohol abuse* which damage both nerves and blood vessels and significantly increase the risk of infections.

Risk factors

Anyone with diabetes can develop neuropathy, but the following factors increase the risk of susceptibility to nerve damage:

- *Poor blood sugar control* is the greatest risk factor for every complication of diabetes, including nerve damage.
- *Duration of diabetes*. The risk of diabetic neuropathy increases with increasing duration of diabetes, especially if there is also poor control of blood sugar. Peripheral neuropathy is most common in people who have had diabetes for at least 25 years.
- *Kidney disease*. Diabetes can cause damage to the kidneys, which may increase the toxins in the blood and contribute to nerve damage.
- *Smoking* narrows and hardens the arteries, reducing blood flow to the legs and feet, making it more difficult for wounds to heal and damages the integrity of the peripheral nerves.

PRESENTATION AND SYMPTOMS

🕒 Early, primary symptoms of diabetic peripheral neuropathy may include:

- tingling, prickling, buzzing, pinching or burning feeling in the feet
- pins and needles in the feet
- sharp, jabbing, stabbing pains
- cramps in the legs and feet
- cold sensation
- numbness or reduced ability to feel pain or changes in temperature, especially in the feet and toes

Symptoms often worsen at night.

🕒 Progressive symptoms of diabetic peripheral neuropathy may include:

- *Touch sensitivity*: heightened and/or extreme sensitivity to touch such as the weight of a sheet or clothes being painful, or heightened tingling or numbness in the toes, feet, legs, or hands
- *Muscle weakness*: difficulty walking or getting up from a chair, grabbing things or carrying things with the hands as a result of muscle weakness from nerve damage
- *Balance problems*: increased unsteadiness and incoordination when walking, occurring as the body adapts to changes brought on by muscle damage
- *Serious foot problems*: such as ulcers, infections, deformities, and bone and joint pain

🕒 Complications: Diabetic neuropathy can cause a number of serious complications. Among the most serious are the following two complications:

- *Loss of a limb*: As nerve damage can cause lack of feeling in the feet, cuts and sores can go unnoticed and eventually become severely infected or ulcerated. The risk of infection is high because diabetes reduces blood flow to the feet. Infections that spread to the bone and cause tissue death (gangrene) may be impossible to treat and require amputation of a toe, foot or even the lower leg. More than half the non-traumatic lower limb amputations performed every year in the United States are due to diabetes.
- *Charcot joint*: This occurs when a joint, usually in the foot, deteriorates because of nerve damage. Charcot joint is marked by loss of sensation, as well as swelling, instability and sometimes deformity in the joint itself.
- *Neuropathic pain* is difficult to control and can seriously affect emotional well-being and overall quality of life. Neuropathic pain is often worse at night, seriously disrupting sleep and adding to the emotional burden of sensory nerve damage.

DIAGNOSIS

Patients being evaluated for diabetic peripheral neuropathy will have already been clinically diagnosed with diabetes and/or be evaluated for and diagnosed with diabetes prior to the evaluation for diabetic peripheral neuropathy.

Diabetic neuropathy is diagnosed by a qualified physician based on a thorough evaluation of the patient's symptoms, medical history and a physical exam that includes assessment of blood pressure, heart rate, muscle strength and tone, tendon reflexes, and sensitivity to touch, position changes, temperature and vibration.

A comprehensive foot exam assessing the skin, muscles, bones, circulation, and sensation of the feet is also performed as part of the diagnostic process.

Specific tests that may be conducted as part of the diagnostic process include:

- *Filament test.* Sensitivity to touch may be tested using a soft nylon monofilament or via pin prick. The inability to feel the filament on the foot or the pin prick is a sign that sensation in those nerves has been lost or diminished.
- *Tuning fork.* A tuning fork is used for quantitative sensory testing to assess vibration and temperature change perception.
- *Nerve conduction studies or electromyography* are sometimes used to help determine the type and extent of nerve damage. Nerve conduction studies check the transmission of electrical current through a nerve. Electromyography evaluates how well muscles respond to electrical signals transmitted by nearby nerves. These tests are rarely needed to diagnose neuropathy.

CURRENT THERAPEUTIC APPROACHES TO THE MANAGEMENT OF CHRONIC PAINFUL DIABETIC PERIPHERAL NEUROPATHY

Nerve pain from diabetic peripheral neuropathy can be severe, constant, and difficult to treat. As diabetic neuropathy is a many-faceted complication of diabetes, it is often best managed symptomatically with an array of drugs and/or treatments. In addition to optimal management of blood glucose levels (including a regimen of diet, exercise and medication), the following medications and therapies, and combinations therein, are used to assist in the management of painful diabetic peripheral neuropathy symptoms:

(i) Over-the-counter (OTC) pain relief options:

- *OTC NSAIDs (nonsteroidal anti-inflammatory drugs)*, such as aspirin, ibuprofen (Advil, Motrin), and naproxen (Aleve) reduce inflammation and relieve pain. A downside of NSAIDs is the potential for harmful side effects such as stomach irritation and bleeding, or even kidney and liver damage, with prolonged use, which may be more likely in people with diabetes.
- *Acetaminophen* medications relieve diabetes nerve pain without reducing inflammation and do not cause the stomach irritation of NSAIDs, but there is a risk of liver damage with excessive use.
- *Capsaicin* is found naturally in chili peppers or in drug stores under various brand names, including Capzasin-P and Zostrix. Capsaicin is believed to ease pain by reducing a chemical called substance P, which is involved in transmitting pain signals through the nerves. Effective on a short-term basis, there are concerns about long-term consequences such as prevention wound healing, which is most serious in patients with diabetes.
- *Lidocaine* is an OTC and/or prescription gel or cream anesthetic that numbs the area of application. Some product names include Topicaine and Xylocaine.
- *Other topical creams* such as salicylate, a chemical similar to aspirin found in pain-relieving creams like Aspercreme and Bengay; cortisone creams containing corticosteroids, potent anti-inflammatory drugs that can help relieve pain. However, there is no clear evidence that either helps relieve nerve pain from peripheral neuropathy.

(ii) Prescription pain relief options:

- *Prescription NSAIDs* such as Celebrex, Lodine, and Relafen. As with the OTC NSAIDs, people with diabetes are at greater risk of kidney damage that can occur with prescription NSAIDs, and at greater risk of heart disease which may also be elevated with prescription NSAID use.
- *Antidepressants*, such as:
 - ✓ *Tricyclic antidepressants (TCAs)* that primarily affect the levels of the brain chemicals norepinephrine and serotonin, such as Elavil, Pamelor and Norpramin. Side effects vary between the three, but can include drowsiness, weight gain, dry mouth, and dry eyes. For people with peripheral neuropathy, there may be additional side effects such as the development of blood pressure, heart rate problems and dizziness.
 - ✓ *Selective serotonin reuptake inhibitors (SSRIs)* that work by altering the amount of the brain chemical serotonin, but these are the least effective for pain management.
 - ✓ *Serotonin and norepinephrine reuptake inhibitors (SNRIs)*, such as Effexor and Cymbalta, affect the levels of the brain chemicals serotonin and norepinephrine. They are quite effective for pain relief with fewer side effects than the SSRIs or TCAs. Cymbalta is FDA-approved for painful neuropathy.
- *Antiseizure drugs* that prevent epileptic seizures can also relieve neuropathic pain by controlling the abnormal firing of nerve cells. These drugs include:
 - ✓ *Neurontin* is most commonly used for nerve pain from peripheral neuropathy. Side effects include causing sedation or dizziness at higher doses.
 - ✓ *Lyrice* is FDA-approved for painful neuropathy. The most common side effects are dizziness and sleepiness.
- *Opioid medicines* such as Ultram and Ultracet, are strong pain killers for when pain is very severe and immediate relief is needed. Ultram and Ultracet are FDA-approved painkillers that contain tramadol, a weak opioid (morphine-like) substance. The drug also weakly affects the brain chemicals serotonin and norepinephrine, similar to antidepressants, which reduces the perception of pain.
- *Tramadol* is often used as a back-up for "breakthrough pain" - pain that suddenly, for no apparent reason, is worse. Tramadol is a good replacement for over-the-counter medications at those times. However, strong narcotic opioid medications can cause severe constipation and have the potential for addiction.

(iii) Additional and Alternative Treatment Options:

- *Injections of local anesthetics such as lidocaine* - or patches containing lidocaine - can be used to numb the painful area for severe, intractable diabetes nerve pain.
- *Surgical destruction* of nerves or to relieve a nerve compression that causes pain.
- *Implantation of a device* that relieves pain.
- *Transcutaneous electrotherapy and percutaneous electrical nerve stimulation* are alternative therapies that provide electrical nerve stimulation wherein small amounts of electricity are used to block pain signals as they pass through the skin.
- *Hand or foot braces* to compensate for muscle weakness or to help relieve nerve compression.
- *Orthopedic shoes* to improve gait (walking) problems to will prevent foot injuries.

THEORY OF MECHANISM OF OPERATION OF THE APPLICATION OF LOW LEVEL LASERTHERAPY TO REDUCING PAIN

"Low-energy photon irradiation by low level laser light lasers or LED arrays has been found to modulate various biological processes in cell culture and animal models. This mechanism of photobiomodulation by LLLT lasers or LED arrays at the cellular level has been ascribed to the activation of mitochondrial respiratory chain components, resulting in initiation of a signaling cascade that promotes cellular proliferation and cytoprotection."

Source: Proc Natl Acad Sci U S A. 2003 Mar 18; 100(6): 3439-44. 2003 Mar 07.

When applied to injuries and lesions, low level laser light has been shown to stimulate healing and to reduce pain by accelerating the speed, quality and strength of tissue repair and the reduction of inflammation. Furthermore, laser therapy has been found to be particularly effective over other standard therapies in relieving pain and other symptoms associated with injuries as it impacts the complete system of targeted muscles, tendons, ligaments, connective tissue, bone, nerve, and dermal tissues.

Lasers can strengthen damaged cells. Using photochemical processes, laser light inserts bio-photons into damaged cells. The cells begin to produce energy (ATP), which improves their function, assists their division, strengthens the body's immune system, and causes the secretion of various hormones. The tissues are healed, and pain diminishes. If damaged cells have died, the bio-photons help the division of neighboring cells, generating new tissues, and thus bring about healing.

Therefore, LLLT promotes healing, regeneration and pain reduction through the following mechanisms:

- 1) increased cell membrane polarization and permeability
- 2) increased ATP production and respiratory chain activity
- 3) increased enzyme activity
- 4) increased collagen and epithelial production
- 5) increased capillary formation
- 6) increased macrophage (immune) activity
- 7) analgesic effects due to elevated endorphin production, electrolytic nerve blockage, and improved blood and lymph flow
- 8) anti-inflammatory effect due to improved circulation and accelerated tissue regeneration; and 9) increased production of antioxidants.

Of additional benefit is that light energy from low level lasers will only be absorbed by those cells and tissues that are not functioning normally and that need it. Soft laser light has no effect on healthy cells.

The progressive process by which low level laser light aids in the production of ATP, consequently providing cells with more energy which in turn optimizes the cells' condition to play their part in a natural healing and pain reduction process, is as follows:

The effects of low level laser light are photo-chemical (not thermal), triggering normal cellular function.

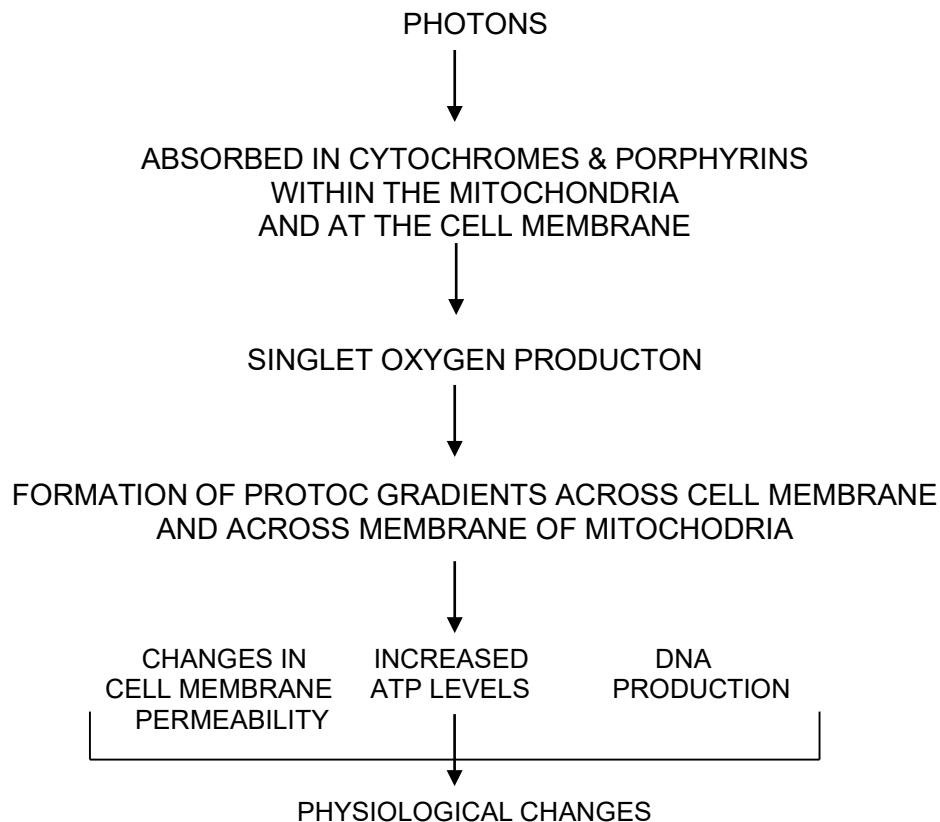

THEORY OF MECHANISM OF OPERATION OF THE APPLICATION OF LOW LEVEL LASER THERAPY TO REDUCING CHRONIC DIABETIC PERIPHERAL NEUROPATHY PAIN

Considering the general mechanism of operation of LLLT as explained above, it follows that LLLT provides relief from the foot pain from chronic diabetic peripheral neuropathy by:

- penetrating the skin of the foot and the ligaments and tendons to increase the production of ATP and activate enzymes in the targeted cells of the tissue to promote healing of the tendons and ligaments
- cultivating a growth factor response within the cells and tissue of the foot as a result of the increased ATP production to promote new, healthier cell and tissue growth to strengthen and support ligaments and tendons, to restore mechanical and sensory function, and to protect against further damage
- The anti-inflammatory properties of low level lasers reduce nerve irritation and inflammation in the foot to provide pain relief

ERCHONIA CORPORATION LLLT LASER DEVICES AND CHRONIC PAIN REDUCTION INDICATIONS

Erchonia Corporation's low level lasers have been shown through controlled clinical trials to be effective for pain reduction, as evidenced through several FDA 510(k) approvals for various indications based on the supportive outcome of those clinical trials, as listed below.

- 1. K132940:** *Erchonia® Allay™*: is indicated as an adjunct to reducing chronic heel pain arising from plantar fasciitis.
- 2. 510(k)#:** K072206: *Erchonia EML Laser*: is indicated for the temporary reduction in post-surgery pain at 24 hours after surgery following bilateral breast augmentation surgery.
- 3. 510(k)#:** K050672: *Erchonia EVRL Laser*: is generally indicated while using the red diode, for adjunctive use in providing temporary relief of minor chronic neck and shoulder pain of musculoskeletal origin.
- 4. 510(k)#:** K041139: *Erchonia EML Laser*: is indicated as an adjunct to liposuction procedures of the thighs, hips and stomach for reduction of pain associated with the recovery process.

STUDY RATIONALE & JUSTIFICATION

The chronic pain of diabetic peripheral neuropathy can be debilitating, impacting the individual's day-to-day functionality that further leads to physical, cognitive, psychological, sleep and social impairments. Additionally, diabetic neuropathic pain patients are typically burdensome to the health care system, frequently seeking relief from the persistent pain. Many afflicted also suffer economically, as coping with the chronic pain of the condition may render them unemployable or under-employed.

Current therapeutic approaches for managing the chronic pain of diabetic peripheral neuropathy are primarily over-the-counter and prescription medications. However, in addition to their general limited effectiveness, many have harmful side effects with prolonged use such as stomach irritation and bleeding, kidney and liver damage, prevention of wound healing, elevated blood pressure and heart rate problems which can be both more likely to occur and more likely to pose serious implications for individuals with diabetes. Additional potential side effects include dizziness, drowsiness, weight gain, dry mouth, and dry eyes, as well as the potential for addiction with certain prescription medications. Non-medication alternatives are also of limited effectiveness and most, including injections of local anesthetics, surgical destruction of nerves, device implantation and transcutaneous electrotherapy and percutaneous electrical nerve stimulation are costly, invasive and carry their own set of potentially harmful and lasting side effects.

Low level laser light therapy, such as that provided through application of the Erchonia® FX-635™ Laser as proposed in this study protocol, offers a simple, quick, non-invasive, safe, effective and side-effect free option to reduce diabetic peripheral neuropathy pain. Prior trials with Erchonia low level lasers have demonstrated their efficacy in reducing chronic pain in various clinically diagnosed chronic pain conditions, and in post-surgical pain, in a clinically meaningful and statistically significant manner, as is the treatment goal being evaluated in the current clinical study.

Specific Justification for the assertion of anticipated safety and effectiveness of the Erchonia® FX-635™ for application to reducing chronic pain arising from diabetic peripheral neuropathy is found through the following FDA clearances for Erchonia® low level laser devices for chronic pain

Erchonia® FX-635™ Diabetic Peripheral Neuropathy Pain Clinical Study Protocol
reduction and post-surgical pain reduction indications, each device of whose technical specifications and outputs are comparable to those of the Erchonia® FX-635™ as presented in the current clinical study protocol:

For all of the respective 510(k) clearances, the assigned Product Code is NHN, defined as follows:

- ✓ *Device:* Powered Light Based Non-Laser Non-Thermal Instrument With Non-Heating Effect For Adjunctive Use In Pain Therapy
- ✓ *Regulation Description:* Infrared lamp
- ✓ *Definition:* A light based non-laser device that emits energy in infrared or other wavelengths, provides non-heating and non-thermal effect, and is indicated for adjunctive use in pain therapy or related indication. It does not provide therapeutic topical heating. The classification regulation for infrared lamps describes a device that emits energy in the infrared wavelength to provide topical heating and that is not limited to adjunctive use.
- ✓ *Device Class:* 2

The above-referenced 510(k) clearances are the following:

- 🕒 *K132940: Erchonia® Allay™:* is indicated as an adjunct to reducing chronic heel pain arising from plantar fasciitis.
- 🕒 *K050672: Erchonia EVRL Laser:* is generally indicated while using the red diode, for adjunctive use in providing temporary relief of minor chronic neck and shoulder pain of musculoskeletal origin.
- 🕒 *K072206: Erchonia EML Laser:* is indicated for the temporary reduction in post-surgery pain at 24 hours after surgery following bilateral breast augmentation surgery.
- 🕒 *K041139: Erchonia EML Laser:* is indicated as an adjunct to liposuction procedures of the thighs, hips and stomach for reduction of pain associated with the recovery process.

Therefore, Erchonia® low level lasers of comparable configuration, technical specification and application as proposed in this current clinical study protocol have been determined to be safe and effective by the FDA for various pain reduction indications, including an indication for reducing chronic heel pain arising from plantar fasciitis, such that evaluation of application of the Erchonia® low level laser to reducing chronic diabetic peripheral neuropathy foot pain is a natural extension of its proven and accepted application for chronic pain reduction purposes.

DEVICE INFORMATION: ERCHONIA® FX-635™

REGULATORY BACKGROUND

The Erchonia® FX-635™ Laser being evaluated in this clinical study for use as an adjunct to reduction of chronic diabetic peripheral neuropathy foot pain is identical to the Erchonia® Allay™ laser device that received FDA 510(k) clearance for market for the following foot pain-reduction related indication:

Device: Erchonia® Allay™

510(k)#: K132940

Manufacturer: Erchonia Corporation

Device Class: Class II

Product Code: NHN

Clearance Date: 04/14/14

Indication for Use: The Erchonia® Allay™ laser is indicated as an adjunct to reducing chronic heel pain arising from plantar fasciitis.

The Erchonia® FX-635™ laser device to be used in this clinical study is identical in design, configuration and technical specifications including dosage output and energy delivered to the skin as the Erchonia® Allay™ whose FDA clearance was attained following review of the outcome of a controlled clinical trial that supported the above indication.

DEVICE DESCRIPTION & DETAILS

The Erchonia® FX-635™ used in this study is made up of 3 independent 17 mW, 635 nm red laser diodes mounted in scanner devices with flexible arms positioned equidistant from each other.

The Erchonia® FX-635™ is a variable hertz device. The variable hertz feature of the Erchonia® FX-635™ is a pulsed wave, defined as containing a selected series of breaks, variances that are preprogrammed.

The Erchonia® FX-635™ utilizes internal mechanics that collects the light emitted from each of the laser diodes and processes each through a proprietary patented lens which redirects the beam with a line refractor. The refracted light is then bent into a spiraling circle pattern that is totally random and independent of the other diodes.

The Erchonia® FX-635™ has the following specifications:

- ✓ Configuration: Class 2 Line Generated Laser Diode Modules
- ✓ Wavelength: 635 nm
- ✓ Power Output (Mean): 17 mW
- ✓ Modulation: Pulsed Wave (50% duty Cycle)
- ✓ Display: Full Color TFT Touch Screen Control Center
- ✓ Adjustments:
 - 44" Vertical Arm Height Adjustment.
 - Three Independent Adjustable Arms
- ✓ Power Source: 100-240 VAC 50-60 Hz
- ✓ Chassis:

- Metal Frame Powder Coated for Ease of Cleaning
- 4 Anti-Static Casters (4 Locking)
- ✓ Housing: Black Carbon Fiber Finish Thermoformed from Non-Allergen Material/Plastic
- ✓ Weight: 70 lbs.

Dosage calculations for the Erchonia® FX-635™

Equations:

1) Intensity = W/cm^2

2) Dosage = $(J/cm^2) = (W/cm^2) \times r(s)$

3) Oval Surface area = $n \times (r1/2) \times (r2/2)$

MW = milliwatts

W = Watts

Intensity:

Intensity .. oval surface area = intensity at tissue

1) $17.5 \text{ mW} / 1000 = 0.0175 \text{ W}$ (Intensity conversion from mW to W)

2) $n \times (9\text{cm}/2) \times (9.5\text{cm}/2) = 21.375 \text{ cm}^2$ (surface area of treated region at single diode at 3.5" above the skin surface.)

3) $0.0175 / 21.375 \text{ cm}^2 = 8.2 \times 10^{-4} \text{ W/cm}^2$ (intensity for single diode at skin)

4) $8.2 \times 10^{-4} \text{ W/cm}^2 \times (3 \text{ diodes}) = 2.46 \times 10^{-3} \text{ W/cm}^2$ (intensity for all 3 diodes combined at the skin)

Dosage delivered to the skin:

Intensity \times r(s) = dosage at specific area

1) $2.46 \times 10^{-3} \text{ W/cm}^2 \times (900 \text{ seconds}) = \mathbf{.0865 \text{ J/cm}^2}$ (total dosage delivered to the skin)

The Erchonia® FX-635™ used in this study is shown in Figures 1 and 2 below.



Figure 1: Erchonia® FX-635™



Figure 2: Erchonia® FX-635™

The Erchonia® FX-635™ System Components is shown in Figures 3 and 4 below.

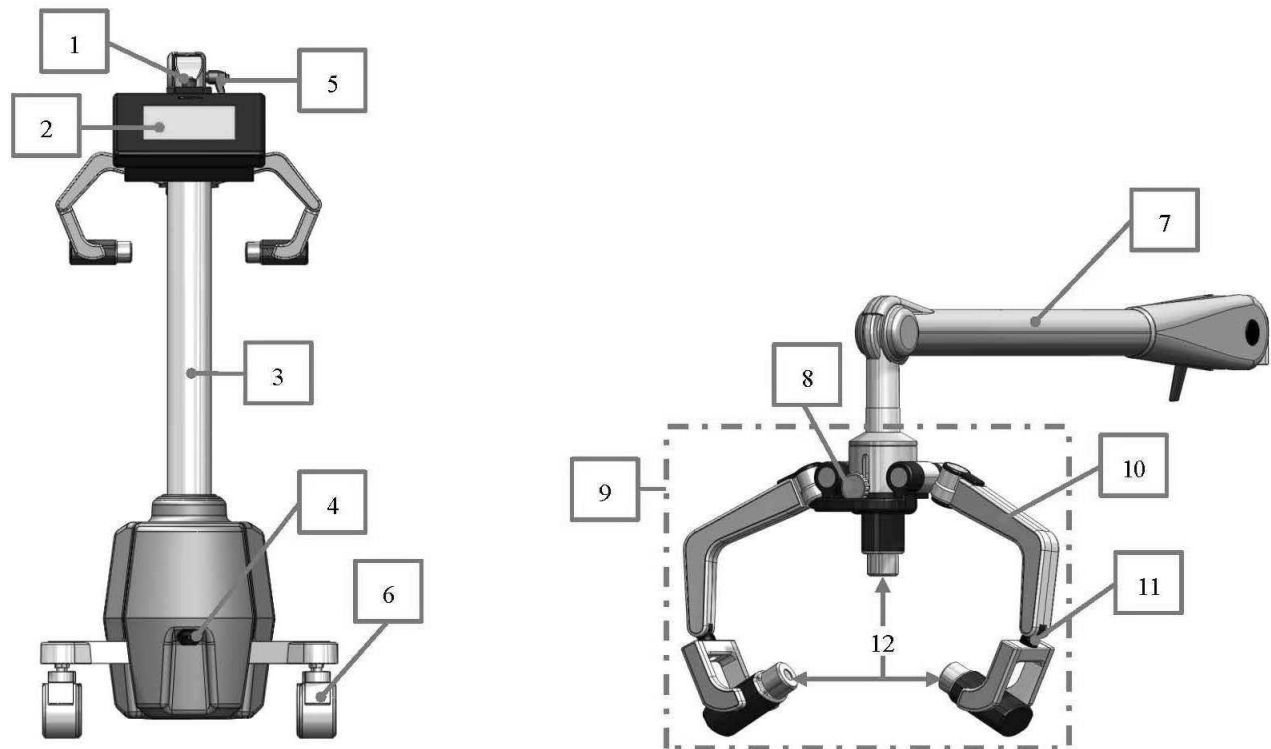

Figure 3: Erchonia® FX-635™ System Components

- | | |
|-----------------------------|--------------------------------------|
| 1. Power Safety Lockout Key | 8. Center Head Adjustment Knob |
| 2. Touch Screen | 9. Laser Head Assembly |
| 3. Main Upright of Base | 10. Upper Arms |
| 4. Power Inlet/Fuse Holder | 11. Upper/Lower Pivots |
| 5. Arm Lock (Fig. 2) | 12. Laser Output Heads |
| 6. Wheel Lock | 13. Locking Knob - not shown |
| 7. Boom Arm | 14. Power Cord - not shown |
| | 15. Electrical Connector - not shown |

POWER SAFETY LOCKOUT KEY (1)

The Power Safety Lockout Key is the outwardly visible portion of an internal locking mechanism on top of the touch screen [2] that comes with an external key. Together they allow the end user to turn the device ON or OFF. ("O" = OFF and "I" = ON) In the OFF position the device is locked.

TOUCH SCREEN (2)

The touch screen functions as a display screen and an input panel, providing information to the user and a means to operate the device by touching the appropriate icon.

MAIN UPRIGHT OF BASE (3)

The main upright of base supports the boom arm and contains the electrical connector (See Setup) and the Locking Knob [13].

POWER INLET/FUSE HOLDER (4)

The device contains an appliance coupler (power inlet) and a flexible detachable power cord [14]. This is the location on the device where the power cord is connected.

ARM LOCK (5)

The Arm Lock is the black lever attached to the side of the Boom Arm. This is a secondary locking mechanism for the boom arm. The arm tension can be adjusted or locked into position with the arm lock lever.

WHEEL LOCKS (6)

The device includes four antistatic wheels that enable ease for maneuverability. Once the device is transported to the desired location the wheel locks can be engaged to eliminate excessive movement of the device.

BOOM ARM (7)

The Boom Arm serves to position the Laser Head Assembly [9] vertically only. It is designed to adjust by intentional force from the end user. This allows the end user to lower and raise the Laser Output Heads for proper positioning to patient for accurate treatment distance.

CENTER HEAD ADJUSTMENT KNOB (8)

The Center Head Adjustment Knob [8] serves to adjust the treatment height of the center head. This also acts as the locking mechanism for the center head.

LASER HEAD ASSEMBLY (9)

This three head assembly located on the end of the laser arm (boom arm) accommodates the laser output heads, pivots, arms and center head adjustment knob. This assembly can be rotated 120 degrees for proper positioning to patient for accurate treatment.

UPPER ARMS (10)

The upper arms serve as a positioning support for Laser Output Heads [12]. It is designed to adjust by intentional force from the end user. This allows the end user to lower and raise the Laser Output Heads for proper positioning to patient for accurate treatment distance.

UPPER/LOWER PIVOTS (11)

The upper and lower pivots serve as a positioning support for Laser Output Heads [12]. It is designed to adjust by intentional force from the end user. This allows the end user to move the laser output heads in and out, as well as side to side for proper positioning to patient for accurate treatment distance.

LASER OUTPUT HEADS (12)

The three plastic housings located on the end of the Lower Pivots [11] as well as the center of laser head assembly [9], accommodates the lens, laser diodes, motors, and their associated electronics. The side heads are designed to adjust by intentional force from the end user; this allows the end user to change the angle of the laser output heads for proper positioning to patient for accurate treatment distance. The center head is designed to be adjusted by center head adjustment knob [8].

LOCKING KNOB (13)

The locking Knob is utilized to secure the two piece assembly [3 & 7], also preventing the boom arm assembly from unwanted rotation during use.

POWER CORD (14)

The device contains a flexible detachable power cord.

ELECTRICAL CONNECTOR (15)

The electrical connector is a two piece assembly. The electrical connector connects the main head assembly to the base assembly in order to transfer data and power.

This pictorial shows the simple 2 piece assembly of the scanner. This assembly is best done with 2 people.

The 2 major components are the arm [7] and base [3].

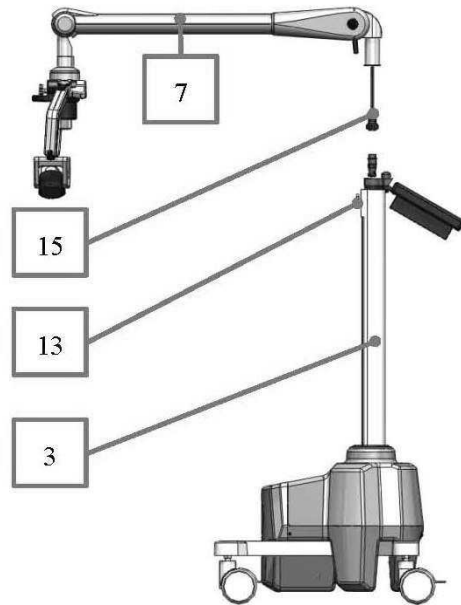

Figure 4: Erchonia® FX-635™ Assembly

DEVICE SAFETY

RISK AND PREVENTION OF EYE INJURY

The Erchonia® FX-635™ is classified by the FDA/IEC as a Class 2 laser device. This designation represents a current standard for use in order to ensure the safety of the subject. A Class 2 laser is determined to have a chronic viewing hazard. Pointing the laser beam directly into the eye and maintaining it there for an extended period of time could prove to be damaging.

To ensure there is no possible instance of residual effect, eye protection is implemented for both the investigator administering the study procedures with the Erchonia® FX-635™ Laser and for the subject receiving the laser procedure administrations.

A pair of specialty safety glasses is provided for use during all procedure applications. These safety glasses are Laser Safety Industries PN: 100-40-240 light blue safety glasses. These safety glasses have the following specifications:

- ✓ OD 4+ @ 630-690 nm
- ✓ OD 7+ @ 690-970 nm
- ✓ OD 5+ @ 970-1100 nm
- ✓ VLT 36%

The Laser Safety Industries PN: 100-40-240 light blue safety glasses are shown in Figures 5 & 6 below.



Figure 5: Laser Safety Industries PN: 100-40-240 Safety Glasses*

*The block out glasses is specifically for the clinical trial



Figure 6: Laser Safety Industries PN: 100-40-240 Safety Glasses Specifications

FOOD AND DRUG ADMINISTRATION (FDA) DETERMINATION OF NON-SIGNIFICANT RISK
(NSR) STATUS

(i) Regulatory Clearances: The Food and Drug Administration (FDA) has determined the family of Erchonia® low level laser devices, including those employing 635 nm red diodes, to be non-significant risk (NSR) through numerous **510(k) clearances**, including several for pain relief indications, as follows.

1. **K132940**: *Erchonia® Allay™*: is indicated as an adjunct to reducing chronic heel pain arising from plantar fasciitis.
2. **K072206**: *Erchonia® EML Laser*: is indicated for the temporary reduction in post-surgery pain at 24 hours after surgery following bilateral breast augmentation surgery.
3. **K050672**: *Erchonia® EVRL Laser*: The Erchonia EVRL Laser is generally indicated:
 - a. while using the red diode, for adjunctive use in providing temporary relief of minor chronic neck and shoulder pain of musculoskeletal origin, and
 - b. while using the blue diode, to treat dermatological conditions, and specifically indicated to treat moderate inflammatory Acne Vulgaris.
4. **K041139**: *Erchonia® EML Laser*: is indicated as an adjunct to liposuction procedures of the thighs, hips and stomach for reduction of pain associated with the recovery process.
5. **K100509 & K130741**: *Erchonia® THL1 Laser & Erchonia® PL5000*: is indicated for adjunctive use in providing temporary relief of minor chronic neck and shoulder pain of musculoskeletal origin.
6. **K130996**: *Erchonia® XLR8™*: The Erchonia XLR8™ is indicated for the following three indications:
 - a. adjunctive use in providing temporary relief of minor chronic neck and shoulder pain of musculoskeletal origin
 - b. as an adjunct to liposuction procedures of the thighs, hips and stomach for reduction of pain associated with the recovery process
 - c. temporary reduction in post-surgery pain at 24 hours after surgery following bilateral breast augmentation surgery
7. **K142042**: *Erchonia® SHL Laser*: is indicated for use as a non-invasive dermatological aesthetic treatment for reduction of circumference of hips, waist and upper abdomen when applied to individuals with a Body Mass Index (BMI) between 30 kg/m² and 40 kg/m².
8. **K130922**: *Erchonia® Verju Laser System with Massager*: is indicated for use as a non-invasive dermatological aesthetic treatment as an adjunct for individuals intending to undergo liposuction procedures for the reduction of circumference of hips, waist and thighs. The Massager component is indicated for the temporary reduction in the appearance of cellulite.
9. **K123237 & K133718**: *Erchonia® Zerona™ 2.0 Laser & Zerona®-Z6*: is indicated for use as a non-invasive dermatological aesthetic treatment as an adjunct for individuals intending to undergo liposuction procedures for the reduction of circumference of hips, waist, and thighs.

10. **K121695 & K082609:** *Erchonia® ML Scanner (MLS) & Erchonia® Zerona:* is indicated for use as a non-invasive dermatological aesthetic treatment as an adjunct for individuals intending to undergo liposuction procedures for the reduction of circumference of hips, waist, and thighs.
 11. **K21690 & K120257:** *Erchonia® MLS, Zerona, Zerona-AD:* is indicated for use as a non-invasive dermatological aesthetic treatment as an adjunct for individuals intending to undergo liposuction procedures for the reduction of circumference of the upper arms.
 12. **K101430:** *MLS-AC Derma Scanner™:* is indicated while using the red diodes for adjunctive use in providing temporary relief of minor chronic neck and shoulder pain of musculoskeletal origin, and while using the blue diode, to treat moderate inflammatory Acne Vulgaris.
 13. **K082609:** *Erchonia® ML Scanner (MLS):* is indicated for use as a non-invasive dermatological aesthetic treatment for the reduction of circumference of hips, waist and thighs.
- (ii) Pre-IDE Reviews: FDA has previously reviewed numerous clinical study protocols employing various Erchonia® Corporation low level laser devices, including all of the clinical studies conducted in support of the above 510(k) clearances and those employing 635 nm red diodes. For all of the FDA's pre-IDE reviews of Erchonia low level laser clinical study protocols, there was concurrence from FDA that the clinical study protocols and application of the Erchonia laser devices therein were considered non-significant risk (NSR).

INSTITUTIONAL REVIEW BOARD (IRB) DETERMINATION OF NON-SIGNIFICANT RISK (NSR) STATUS

Erchonia® Corporation low level laser devices have been determined to be non-significant risk (NSR) when applied in various clinical studies through several IRBs, including those involving application of 635 nm red diode energy and application for pain reduction indications, as follows:

-  Western Institutional Review Board (WIRB®) has previously determined Erchonia low level laser devices to be non-significant risk (NSR) when applied in the following clinical studies:
1. **WIRB PRO NUM: 20141594:** Erchonia® Verju™: An evaluation of the effect of the Erchonia® Verju™ laser with Suprenza™ to reduce central adiposity in overweight and obese individuals
 2. **WIRB PRO NUM: 20140748:** Erchonia® ZERONA® Z6: Evaluation of efficacy, usability and labeling comprehension for over-the-counter use of the Erchonia Corporation ZERONA® Z6 for body contouring of the waist, hips and thighs
 3. **WIRB PRO NUM: 20140535:** Erchonia® EML Laser: A randomized evaluation of the effect of the Erchonia® EML laser on the autologous transfer of fat to the hands from fat harvested during laser-assisted liposuction of the thighs and/or hips and/or stomach pilot study
 4. **WIRB PRO NUM: 20131165:** Erchonia® ZERONA 6 Headed Scanner (EZ6): An evaluation of the effect of the Erchonia® ZERONA 6 Headed Scanner (EZ6) six-week treatment protocol on circumference reduction of the waist, hips, thighs and upper abdomen clinical study

5. **WIRB PRO NUM: 20130851:** Erchonia® ML Scanner (MLS): An evaluation of the effect of the Erchonia® ML Scanner (MLS) laser on increasing blood circulation in individuals with chronic heel pain clinical study
6. **WIRB PRO NUM: 20130488:** Erchonia® TMJ laser: A pilot evaluation of the effect of the Erchonia® TMJ Laser on reducing jaw pain and improving jaw function for individuals with temporomandibular joint (TMJ) disorder
7. **WIRB PRO NUM: 20130343:** Erchonia® Obesity Laser: A double-blind, placebo-controlled randomized evaluation of the Erchonia® Obesity Laser on the reduction of the circumference of the hips, waist and upper abdomen for individuals with Body Mass Index (BMI) of 40 to 40 kg/m²
8. **WIRB PRO NUM: 20121548:** Erchonia® MLS: A double-blind, placebo-controlled randomized evaluation of the effect of the Erchonia® ML Scanner (MLS) laser on reducing pain associated with degenerative arthritis (osteoarthritis) of the midfoot clinical study protocol
9. **WIRB PRO NUM: 20120787:** Erchonia® MLS: A double-blind, placebo-controlled randomized evaluation of the effect of the Erchonia® ML Scanner (MLS) on low back pain clinical study protocol
10. **WIRB PRO NUM: 20111793:** Erchonia® MLS: A double-blind, placebo-controlled randomized evaluation of the effect of the Erchonia® ML Scanner (MLS) laser on chronic heel pain clinical study protocol
11. **WIRB PRO NUM: 20110331:** Erchonia® MLS: An evaluation of the effectiveness of the Erchonia® ML Scanner (MLS) as a non-invasive dermatological aesthetic treatment for the reduction of circumference of the upper arms clinical study protocol
12. **WIRB PRO NUM: 20120911:** Erchonia® MLS: A double-blind, placebo-controlled randomized evaluation of the effect of the Erchonia® ML Scanner (MLS) on body contouring of the waist, hips and thighs five-day treatment protocol clinical study protocol
13. **WIRB PRO NUM: 20110758:** Erchonia® MLS: A pilot evaluation of the effect of the Erchonia® ML Scanner (MLS) laser device on enhancing body weight loss, fat loss and circumference reduction of the waist, hips and thighs clinical study protocol
14. **WIRB PRO NUM: 20121330:** Erchonia LUNULA™: An Evaluation of the Effect of the Erchonia LUNULA™ on Treating Toenail Onychomycosis Clinical Study Protocol; Version 6.0 August 7, 2012
15. **WIRB PRO NUM: 20110461:** Erchonia FX-405™: An Evaluation of the Effect of the Erchonia FX-405™ on Treating Toenail Onychomycosis Clinical Study Protocol; Version 3.0 March 19, 2011
16. **WIRB PRO NUM: 20120489:** Erchonia® MLS: A double-blind, placebo-controlled randomized evaluation of the effect of the Erchonia® ML Scanner (MLS) on lipid panel levels clinical study protocol

⌚ Independent Review Consulting, Inc.'s/Ethical and Independent Review Services has previously determined Erchonia low level laser devices to be non-significant risk (NSR) when applied in the following clinical studies:

1. **IRC# 07150, NSR# DER-006:** Erchonia® MLS: A double blind, placebo-controlled randomized evaluation of the effect of the Erchonia® ML Scanner (MLS) on body contouring of the waist, hips and thighs clinical study protocol.
2. **IRC# 09120, NSR# DER-015:** Erchonia® MLS: A double-blind, placebo-controlled randomized evaluation of the effect of the Erchonia® ML Scanner (MLS) on reducing the appearance of cellulite clinical study protocol.
3. **IRC# 08167, NSR# DER-009:** Erchonia® MLS: A double blind, placebo-controlled randomized evaluation of the effect of the Erchonia® ML Scanner (MLS) on capsular contracture clinical study protocol.
4. **IRC# 09059, NSR# DER-010:** Erchonia® MLS: A double blind, placebo-controlled randomized evaluation of the effect of the Erchonia® ML Scanner (MLS) in combination with silicone sheets on cellulite pilot study protocol.

⌚ Chesapeake Research Review, Inc. determined the Erchonia® ML Scanner (MLS) laser device to be a non-significant risk (NSR) device when applied in the following study:

1. **Pro. # 00006393:** Erchonia® MLS: A pilot evaluation of the effect of the Erchonia® ML Scanner (MLS) as applied to the abdomen on reducing visceral abdominal fat in patients with HIV-associated lipodystrophy.

OTHER POTENTIAL RISKS

Other potential risks and their mitigation include:

- (i) Electric shock: operator risk only: mitigated through electrical safety testing.
- (ii) Electromagnetic interference: mitigated through EMC/EMI testing.
- (iii) User error: mitigated through instructions for use documentation.

STUDY DESIGN

This clinical study is a double-blind, placebo-controlled randomized parallel group design multi-site evaluation of the effect of the Erchonia® FX-635™ on providing relief of chronic foot pain arising from diabetic peripheral neuropathy.

SUBJECT GROUPS

Each subject will be randomized to the test procedure group or to the placebo procedure group, as follows:

Test procedure group: Subjects randomized to the test procedure group will receive the study procedures with the active (true) Erchonia® FX-635™ laser.

Control procedure group: Subjects randomized to the control procedure group will receive the study procedures with a 'fake' (placebo) Erchonia® FX-635™ laser.

The 'fake' (placebo) laser device will appear to the subject to be an active device, but will not produce any therapeutic light output. The placebo laser device is designed to have the same physical appearance as the actual (active test) laser device, including the appearance of any **visible** light output. Therefore, both the test and control devices emit light when activated that is indistinguishable to the subject. As the laser light does not put out any notable degree of heat or noise, these are not distinguishing factors for subjects between the active and control devices.

Apart from the distinction of whether or not the subject receives the study procedures with the actual or the fake laser device, all subjects and investigative parties will adhere to all phases of the entire protocol design.

DOUBLE BLIND DESIGN

This clinical study will be a double-blind design, such that neither the subject nor the investigator will be aware of whether a subject is receiving the study procedures with the active (test procedure group assignment) or the 'fake' (placebo procedure group assignment) Erchonia® FX-635™ until after the study is completed .

Maintenance of study double-blind throughout the entire course of the study will be achieved through the following means:

- 1) Each subject will be randomly assigned to Procedure Group A or to Procedure Group B by the independent study Monitor. Subjects assigned to Procedure Group A will be treated with the Erchonia® FX-635™ A and subjects assigned to Procedure Group B will be treated with Erchonia® FX-635™ B. Only the study Sponsor will know which label ('A' or 'B') corresponds to the actual (test) FX-635™ device and which label corresponds to the 'fake' device until the final study data analysis is complete. The Sponsor will ensure that this information is stored and maintained confidentially at the Sponsor's work site. This knowledge will not be shared with the investigators, the subjects, or the study Monitor until the final data analysis is complete.
- 2) The fake (placebo) Erchonia® FX-635™ is designed to have the same physical appearance as the actual Erchonia® FX-635™, including the appearance of any **visible** light output, with the placebo device employing a 635 nm LED rather than a 635 nm laser diode in the active device. Therefore, both the test and sham devices emit light when activated that is indistinguishable to both the subject and to the investigator. As the laser light does not put out

any notable degree of heat or noise, these are not distinguishing factors for subjects between the two groups.

- 3) There will be two independent investigators interacting with subjects: (i) *administration investigator*: who will be responsible for administering the study treatments; (ii) *assessment investigator*: who will be responsible for recording the study outcome measures. Only the administration investigator will be aware of whether a subject is assigned to Procedure Group A or B, although he or she will not be made aware of whether A or B corresponds to the true or fake laser. Neither the assessment investigator nor the subject will be aware of the subject's A/B Group assignment. In this way, the assessment investigator will not be able to form an association between A/B Procedure Group and active/sham device over the course of the study if a treatment effect is observed.
- 4) During the laser procedures, both the subject and the administration investigator will wear safety glasses that filter out the laser light spectrum.

RANDOMIZATION

Subject allocation to procedure group will be via variable block randomization with varying block sizes of two, four and six used at random to minimize the likelihood of predicting the next procedure group assignment. In addition, randomization will be stratified by test site.

Randomization will be attained using computer generation sequence methodology, insuring that the randomization methodology and the generated allocation sequence is concealed from the investigator and subjects.

Concealment will be insured as follows:

- (ii) Each computer generated randomization sequence is unique and will therefore not be able to be replicated.
- (iii) Randomization will occur to either 'Procedure Group A' or to 'Procedure Group B' rather than to a test or placebo group, and only the study Sponsor will know which assignment (A or B) corresponds to the active device and which corresponds to the fake device. The Sponsor will not reveal this information to any source (investigators, subjects, or study Monitor) until the final study data analysis is complete.

Once a subject has qualified for and been enrolled in the study, the Principal Investigator will contact the study Monitor who will act as the central source for providing sequential subject procedure group assignment.

SUBJECTS

Subject Sample

Subjects will be males and females aged 18 years or older who have diagnosed diabetic peripheral neuropathy with pain persisting over at least the past three months.

Sample size

There will be 64 qualified subjects enrolled in this clinical study:

- 32 subjects in the active procedure group
- 32 subjects in the control procedure group

Rationale for sample size

Based on the following parameters established for the purposes of assessing efficacy of the Erchonia® FX-635™ in this clinical study - :

- ⌚ Individual subject success criteria is defined as a 30% or greater reduction in self-reported Degree of Pain rating on the 0-100 VAS from baseline to study endpoint evaluation.

N.B.: The clinical relevance of a 30% change in VAS score is explained and supported in the STATISTICAL ANALYSIS PLAN section further along in this protocol document.

- ⌚ Overall study success criteria of at least a 35% difference between the test device group and the placebo group, comparing the proportion of individual successes in each group.
- ⌚ It is anticipated that about 55% of subjects in the test device group and about 20% of subjects in the placebo group will meet the individual success criteria, and
- ⌚ intended application of a two-tailed test with an alpha value of 0.05 and Power of 0.8

- the sample size of 29 subjects per group (test group and the control group, separately) has been determined using the following reference calculator: *Hypothesis Testing: Categorical Data - Estimation of Sample Size and Power for Comparing Two Binomial Proportions* in Bernard Rosner's *Fundamentals of Biostatistics*.

For the purposes of sample size calculation, it is anticipated that about one-twentieth of subjects overall may withdraw from the study prior to completion for various reasons. Therefore, the following formula is used to determine the final needed starting sample size for each group:

Final sample size = sample size X 1/(1-d); where d = # expected dropouts/# subjects enrolled.
Final sample size = 29 X 1/(1-0.083)
Final sample size = 29 X 1/0.917 = 29 X 1.0905 = 31.62, rounded to 32 subjects per procedure group.

Therefore, a minimum starting sample size of 32 subjects in each group is needed to insure that a sufficient number remains at the end of the trial (29 subjects per group) for any significant differences found between groups to be considered statistically valid and representative of the general population being sampled. This results in a total of 64 subjects being enrolled in this study across both study procedure groups.

Recruitment

Subjects will be recruited from among the Principal Investigator's/test site's pool of patients who are currently being treated for, or who are seeking treatment for, diagnosed diabetic peripheral neuropathy, or from response to the following recruitment materials.

a) Flyer

WANTED

**ADULTS WITH DIABETES WITH FOOT PAIN
ONGOING OVER THE LAST 3 MONTHS FOR A
CLINICAL STUDY OF THE EFFECTS OF
LOW LEVEL LASER LIGHT ON
REDUCING FOOT PAIN**

**THIS STUDY INVOLVES TWELVE
LASER LIGHT PROCEDURES
WITH THE ERCHONIA® FX-635™ LASER
OVER SIX WEEKS AT THE TEST SITE.**

THERE ARE THREE MORE VISITS TO THE TEST SITE
TWO WEEKS, FOUR WEEKS AND THREE MONTHS
AFTER THE LAST LASER LIGHT PROCEDURE.

FOR MORE INFORMATION PLEASE CONTACT:

<PI name>
<test site name & location>
<phone # and/or e-mail>

b) Newspaper Ad

Diabetic Foot Pain Research Study

This study is to see if the Erchonia® FX-635™, a non-invasive, investigational device that uses low-level laser light, can help to relieve foot pain in people with diabetes that has been ongoing for at least 3 months.

The study involves fifteen visits to a test site and recording some information at home.

Please contact <PI name> at
<test site name & location> at
<phone and/or e-mail> for details.

Compensation

A subject will not receive financial or any other form of compensation to participate in this clinical study. However, he or she will also not be charged for the cost of the study procedures with the Erchonia® FX-635™ Laser or for the cost of any other directly-related evaluations or measurements that occur as part of his or her participation in the study.

STUDY PROCEDURE

STUDY TEST BATTERY

The following is a list of the study outcome assessment tools that will be used in this clinical study. For each study phase, the precise tools from this list that will be employed will be specified.

BASELINE FOOT VARIABLES: The following is recorded at baseline evaluation:

- (i) Duration of Pain: years/months since foot pain began
- (ii) Number of Months/Years Since Diabetes Diagnosis
- (iii) Insulin Dependency: Insulin dependent diabetes or non-insulin dependent diabetes

BASELINE CONCOMITANT MEDICATION AND THERAPY USE: The following is recorded at baseline evaluation:

- (i) Over-the-counter and prescription medications currently used, and therapies currently engaged in by the subject for any non-pain relief indication, including dosages and frequency of use.
- (ii) Over-the-counter and prescription medications that have been used specifically to relieve the subject's diabetic peripheral neuropathy foot pain.
- (iii) Non-drug treatments/therapies (conventional, alternative and experimental) that have been used specifically to relieve the subject's diabetic peripheral neuropathy foot pain.

SUBJECT DEMOGRAPHICS: The subject's age, gender and ethnicity are recorded.

VISUAL ANALOG SCALE (VAS) DEGREE OF PAIN RATING: Subjects will be asked to rate the overall degree of pain experienced in the target foot region on the following 0-100 mm (0 -10 cm) Visual Analog Pain Scale, by responding to the following question:

"Using the scale below, please mark with a cross (X) the spot along the 0 to 100 line below that best shows how much pain you feel in your feet right now. '0' means you feel no pain at all and '100' means you feel the worst pain imaginable. Please mark only one spot."



The Visual Analog Pain Scale (VAS) is one of the three most commonly used scales for assessing chronic pain. It is a simple scale that consists of a line anchored at one end by a label such as "NO PAIN" and at the other end "WORST POSSIBLE PAIN". The subject marks on the line the spot for the pain intensity, which is then measured.

Standard guidelines for effective use of the VAS that are followed in this clinical study are:

- i. The line should be 10, 15 or 20cm long, as other lengths are less reliable.
- ii. There should be a small vertical mark at each end, with numbers 0 and 100, and a verbal description.
- iii. The verbal description must be in absolute terms (e.g. worst pain imaginable);
- iv. The line itself should be clear of any markings and should be horizontal rather than vertical, for more reliable measurements.

Used in the above way, it has been shown that the VAS is a proper ratio scale. Like a thermometer, this means that its two ends are rooted, and a doubling of the score does accurately

reflect a doubling of the pain. Consequently, sensitive t-tests and ANOVA methods can be used in the analysis, so that significant differences can be identified with relatively small sample sizes or small differences between groups.

Source: *Measuring Pain* by Adrian White, *Acupuncture in Medicine*, November 1998 - Vol 16 No. 2

The subject is instructed to refrain from consuming any pain relief medication within 4 hours of recording a required VAS Degree of Pain Rating to ensure that the effect of the pain relief medication does not influence any potential treatment effect of the study procedure with the Erchonia® FX-635™ as evidenced through the VAS ratings. The subject may take a dosage of his or her study rescue pain relief medication immediately after recording a VAS rating, if needed.

NEUROPATHIC PAIN SYMPTOM INVENTORY (NPSI): The NPSI was developed in 2004 by Bouhassira Didier to evaluate the different symptoms of neuropathic pain in adults. It is a 12-item self-administered patient-reported outcome (PRO) assessment tool with a recall/ observation period of over the past 24 hours. It contains 10 descriptors representing 5 distinct dimensions on the basis of factor analysis: burning pain, deep pain, paroxysmal pain, evoked pain, paresthesia/dysesthesia, and 2 temporal items designed to assess pain duration and the number of pain paroxysms. The NPSI has been validated in patients with definite neuropathic pain of peripheral or central origin.

The development and validation of the NPSI is contained in the abstract below:

SUBJECT DAILY DIARY: Commencing upon administration of the first Erchonia® FX-635™ laser procedure to the foot through to completion of the 4-week post-procedure evaluation phase, the subject will be required to complete a Subject Daily Diary at home with the following information, as applicable:

- ✓ *Rescue Pain Medication Use:* The subject will record each time a dose of the study rescue pain medication is taken as needed to manage knee pain.
- ✓ *Confirmation of Abstinence from Other Pain Medication Use:* The subject will confirm at the end of each day that he or she refrained from consuming any OTC and/or prescription medication(s) for the indication of pain relief other than the study pain relief rescue medication during that day
- ✓ *'Other' Medication Use:* The subject will record at the end of each day any medication(s) he or she consumed that day that was different from that reported during Baseline evaluation.
- ✓ *Adverse Events* recording, as applicable.
- ✓ *Additional comments*, as desired

SUBJECT SATISFACTION WITH FOOT PAIN LEVEL: The subject is asked to rate how satisfied he or she is with the level of foot pain experienced at the relevant evaluation points following completion of the laser administration procedures with the Erchonia® FX-635™, by using the 5-point Likert scale presented below to respond to the following question: "Overall, how satisfied or dissatisfied are you with any change in the pain in your feet following the study procedures with the study laser device?"

- Very Satisfied
- Somewhat Satisfied
- Neither Satisfied nor Dissatisfied
- Not Very Satisfied
- Not at All Satisfied

SUBJECT PERCEIVED GROUP ALLOCATION AND RATIONALE: The subject records whether he or she believes to have received the study procedures with the true or fake Erchonia® FX-635™ and records verbatim his or her reasoning or rationale for this perceived determination.

ASSESSMENT INVESTIGATOR PERCEIVED GROUP ALLOCATION AND RATIONALE: The Assessment Investigator records whether he or she believes the subject to have received the study procedures with the true or fake Erchonia® FX-635™ and records verbatim his or her reasoning or rationale for this perceived determination.

RESCUE PAIN MEDICATION USE: As subjects in this study are those that present with a chronic pain level of 50 or greater on the 0 to 100 VAS pain scale, it is unethical to require subjects in this clinical study to refrain from consuming any and all medication(s) indicated for the relief of pain, particularly for subjects assigned to the placebo group. Therefore, this clinical study will incorporate the use of rescue pain medication, to be taken as needed throughout the subject's participation in the clinical study.

The rescue medication to be used in this study will be over-the-counter Regular Strength Tylenol® tablets. Subjects will be instructed to take a dosage of Tylenol as needed to control any foot pain he or she may be experiencing, ensuring that the directions for use are followed.

Subjects will be instructed to record each time a dosage of the pain medication is taken during the study procedure administration and evaluation phase in the Subject Daily Diary.

Subjects will be instructed not to take a dose of any other over-the-counter or prescription medications for the indication of pain relief, including NSAIDs, over the course of study participation.

Subjects will be instructed not to record a VAS pain rating (whenever indicated) any sooner than six hours after they have consumed a dosage of the study pain relief rescue medication. This is to ensure that the effect of the pain relief medication does not influence the effect of the study procedures with the Erchonia® FX-635™ Laser device. That is, a VAS rating is only to be recorded once the effect of any previously-consumed rescue pain medication has dissipated. The subject will be able to take another dosage of the study pain relief rescue medication immediately after recording the VAS rating, if needed.

Throughout the course of his or her study participation, a subject can continue to take any other over-the-counter and/or prescription medication(s) that he or she usually takes for any other (non-pain relief) indication(s), as he or she usually takes them, as reported at Baseline evaluation and approved by the study investigator. Subjects will be required to record any deviations from Baseline reported medication use throughout the course of study participation.

STUDY PROCEDURE PROTOCOL

PRE-PROCEDURE ACTIVITIES

The pre-procedure activities will be conducted at the test site prior to administration of the initial study procedure with the Erchonia® FX-635™.

STUDY QUALIFICATION

SIGNING OF INFORMED CONSENT FORM

The PI will commence by presenting and reviewing in detail the items in the informed consent form with the individual and answer any questions he or she may have. To proceed, the individual must willingly sign the informed consent form.

ASSIGNMENT OF SUBJECT IDENTIFICATION NUMBER

The subject will be assigned a unique subject identification number based upon his or her order of entry into the study.

Additional information about the informed consent and subject ID number assignment is contained in a later section of the protocol titled, "SAFETY AND CONFIDENTIALITY ISSUES."

STUDY QUALIFICATION EVALUATION: INCLUSION/EXCLUSION CRITERIA

INCLUSION CRITERIA

To be eligible for study participation, a subject must satisfy each of the following criteria.

- ⌚ Existing clinical diagnosis of diabetes induced Peripheral Neuropathy documented by a suitably qualified and licensed medical professional
- ⌚ Significant spontaneous foot pain that occurs approximately equally (comparably) bilaterally
- ⌚ Significant spontaneous pain of 50 or greater on the 0-100 VAS for the feet overall
- ⌚ Foot pain is chronic, defined as having been ongoing for at least 3 months, bilaterally
- ⌚ Subject has been on a stable anti-diabetic medication regimen for the prior 30 days or on no anti-diabetic medication regimen for the prior 30 days
- ⌚ Subject is willing and able to refrain from consuming any over-the-counter and/or prescription medication and/or herbal supplements intended for the relief of pain and/or inflammation, including muscle relaxants throughout the course of study participation, except for the study-specific pain relief medication of over-the-counter Tylenol.
- ⌚ Subject is willing and able to refrain from engaging in any non-study procedure therapies for the management of his or her foot pain throughout the course of study participation, including conventional therapies such as physical therapy, occupational therapy and hot or cold packs, as well as alternative therapies such as chiropractic care and acupuncture
- ⌚ Subject agrees to complete the post-procedure phase Subject Diary, as applicable.
- ⌚ 18 years of age or older
- ⌚ Male or female
- ⌚ Subject's primary language is English.

EXCLUSION CRITERIA

A subject who satisfies any of the following criteria will be excluded from study participation:

- 🕒 Subject does not have a definitive clinical diagnosis of diabetes induced Peripheral Neuropathy documented by a suitably qualified and licensed medical professional.
- 🕒 Subject's foot pain is undiagnosed, or has been diagnosed by a qualified medical professional as being other than, or in addition to, diabetes induced Peripheral Neuropathy (such as due to drugs, poisoning, cancer or genetic conditions)
- 🕒 Subject's foot pain is unilateral or notably different between the two feet (such that the pain in one foot is notably lesser/greater than in the other)
- 🕒 Subject's self-reported Degree of Pain rating on the VAS pain scale is less than 50 for both feet overall
- 🕒 Serious organ disease or other serious primary disease merger
- 🕒 Diabetes ketosis, ketoacidosis or severe infection within the past two weeks
- 🕒 Current, active chronic pain disease: chronic fatigue syndrome, fibromyalgia, endometriosis, inflammatory bowel disease, interstitial cystitis, peripheral vascular disease
- 🕒 Cancer or treatment for cancer in the past 6 months
- 🕒 Subject's foot pain is not chronic; that is, it has not been ongoing for at least the prior three months in both feet
- 🕒 Use of any one or more of the following analgesics, or an equivalent, within 7 days prior to initiation of the study procedure administration with the Erchonia® FX-635™:
 - ✓ OTC NSAIDs (nonsteroidal anti-inflammatory drugs) such as aspirin, ibuprofen (Advil, Motrin) and naproxen (Aleve),
 - ✓ prescription NSAIDs such as Celebrex, Lodine and Relafen

N.B.: If any of the above analgesics have been taken within 7 days prior to administration of the initial study procedure, the subject will remain eligible for study participation if he or she agrees to refrain from use of the analgesic(s), and it is medically prudent for him or her to do so, for 7 days prior to initial study procedure administration

- 🕒 Use of any of the following antidepressants within 30 days prior to initiation of the study procedure administration with the Erchonia® FX-635™ IF consumption of the drug has commenced within that 30 day period:
 - ✓ Tricyclic antidepressants (TCAs) such as Elavil, Pamelor and Norpramin; amitriptyline
 - ✓ Selective serotonin reuptake inhibitors (SSRIs) such as Paxil, paroxetine, fluoxetine (Prozac)
 - ✓ clomipramine (Anafranil)
 - ✓ desipramine (Norpramin)

N.B.: If the subject has been on a stable dosage any of the above, or any equivalent, antidepressant agent for at least 90 days prior to initial procedure administration, during which time foot pain has been ongoing, then he or she will remain eligible for participation in the clinical study provided that he or she is willing and agrees to maintain that stable dosage throughout the follow-up evaluation phase of the clinical study, and it is medically prudent for him or her to do so.

- 🕒 Use of any of the following prescription medications within 30 days prior to initiation of the study procedure administration phase:

- ✓ *Neurontin*
- ✓ *Lyrica*
- ✓ *Tramadol*
- ✓ *Opioid medicines* such as Ultram and Ultracet

N.B.: If the subject has been on a stable dosage any of the above, or any equivalent, agents for at least 90 days prior to initial procedure administration, during which time foot pain has been ongoing, then he or she will remain eligible for participation in the clinical study provided that he or she is willing and agrees to maintain that stable dosage throughout the follow-up evaluation phase of the clinical study, and it is medically prudent for him or her to do so.

- ⌚ Injections of local anesthetics such as lidocaine within the past 30 days
- ⌚ Surgical intervention to treat diabetic peripheral neuropathy foot pain, including implantation of a pain relief device
- ⌚ Subject is not willing, or is unable, or it is not medically prudent for the subject, to refrain from engaging in any non-study procedure therapies for the management of his or her foot pain throughout study participation, including conventional therapies such as physical therapy, occupational therapy, as well as alternative therapies such as chiropractic care and acupuncture
- ⌚ Subject does not agree or is unable to complete the Subject Diary, as applicable, through to his or her study completion
- ⌚ Active infection, wound or other external trauma to the areas to be treated with the laser
- ⌚ Medical, physical, or other contraindications for, or sensitivity to, laser therapy
- ⌚ Pregnant, breast feeding, or planning pregnancy prior to the end of study participation
- ⌚ Serious mental health illness such as dementia or schizophrenia; psychiatric hospitalization in the past two years
- ⌚ Developmental disability or cognitive impairment that in the opinion of the investigator would preclude adequate comprehension of the informed consent form and/or ability to record the necessary study measurements
- ⌚ Involvement in litigation and/or receiving disability benefits related in any way to the parameters of the study
- ⌚ Subject is less than 18 years of age
- ⌚ Participation in a clinical study or other type of research in the past 30 days
- ⌚ Subject's primary language is other than English

PRE-PROCEDURE WASHOUT PHASE: 48 HOURS PRIOR TO COMMENCEMENT OF THE PRE-PROCEDURE EVALUATION PHASE

The pre-procedure washout phase comprises the 48-hour period immediately preceding the pre-procedure evaluation phase, beginning upon waking on the first 24-hour period.

At the start of the pre-procedure washout phase, the subject commences his or her required abstinence from use of non-study related medications and therapies for the relief of foot pain and also commences the as-needed consumption of the study rescue medication – OTC Tylenol – for his or her foot pain, that will continue through to the end of the post-procedure evaluation phase.

PRE-PROCEDURE WASHOUT PHASE MEASURES

On each day of the two-day Baseline Washout period, the subject records the following measures, as outlined in the STUDY TEST BATTERY section above.

- 🕒 Subject Daily Diary (all applicable measures)
- 🕒 Visual Analog Scale (VAS) Degree of Pain Rating
- 🕒 Confirmation of Qualifying VAS Rating: **Prior to the subject commencing the pre-procedure evaluation phase of the study, the investigator reviews the average of the 2 VAS foot pain scores recorded during the 48 hour pre-procedure washout phase. In order for the subject to proceed, the 2-day average VAS score must be 50 or greater. If it is less than 50, the subject's participation in the study ends at this time.**

SUBJECT GROUP RANDOMIZATION

A fully qualified subject will be randomly assigned to Procedure Group A or to Procedure Group B, following the methodology outlined above in the STUDY DESIGN section of the protocol.

PRE-PROCEDURE EVALUATION PHASE

The pre-procedure evaluation phase commences on the day following successful completion of the two-day pre-procedure washout phase.

PRE-PROCEDURE VARIABLES

The following pre-procedure variables will be recorded prior to commencement of the procedure administration phase (prior to procedure administration #1), as listed and described in the STUDY TEST BATTERY section above.

- 🕒 Baseline Foot Variables
- 🕒 Baseline Concomitant Medication and Therapy Use
- 🕒 Subject Demographics

PRE-PROCEDURE MEASURES

The following pre-procedure measures will be recorded prior to commencement of the procedure administration phase (prior to procedure administration #1), as listed and described, and according to the methodology outlined, in the STUDY TEST BATTERY section above.

- 🕒 Visual Analog Scale (VAS) Degree of Pain Rating
- 🕒 Neuropathic Pain Symptom Inventory (NPSI)

PROCEDURE ADMINISTRATION PHASE

PROCEDURE ADMINISTRATION PROTOCOL

- ⌚ The procedure administration phase of the study commences within one hour subsequent to recording of the pre-procedure measures and variables, on the same day.
- ⌚ The procedure administration phase extends over 6 consecutive weeks.
- ⌚ Each subject receives 12 total procedure administrations with the Erchonia® FX-635™ across the consecutive 6-week procedure administration phase, 2 procedure administrations per week, each procedure administration approximately evenly spaced.
- ⌚ Each procedure administration lasts a total of 15 minutes per foot, for a total combined procedure administration time of 30 minutes per session.
- ⌚ Each procedure administration with the Erchonia® FX-635™ is administered at the investigator's test site.
- ⌚ The procedure administration protocol for each session is as follows:
 1. The subject enters the procedure administration room and is seated on a chair with the right foot elevated.
 2. The subject is correctly fitted with the laser safety glasses.
 3. The procedure administrator puts on the laser safety glasses and selects the Erchonia® FX-635™ Laser A or B according to the subject's procedure group assignment.
 4. The FX-635™ Laser is positioned around the foot such that each of the 3 laser lights is positioned between 3 and 4 inches away from, but directed toward, a) the top of the foot (dorsal aspect); b) the bottom of the foot (plantar aspect); and c) the posterior tibial nerve within the tarsal tunnel.
 5. The FX-635™ Laser is activated
 6. The laser diodes lase each of these 3 areas for 15 minutes simultaneously.
 7. The procedures listed in 4. through 6. above is repeated for the left foot.
 8. The investigator and the subject remove the safety glasses.
 9. The subject rises and leaves the procedure administration room.

At each of the procedure administration test site visits, the investigator performs an adverse events evaluation.

PROCEDURE ADMINISTRATION PHASE MEASURES

DAILY MEASURES

Commencing on the same day as the first study procedure administration with the Erchonia® FX-635™ is administered, the subject will begin to record all of the required information in the Subject Daily Diary, as applicable, at home.

FOLLOWING EACH PROCEDURE ADMINISTRATION

Within 10 minutes following administration of each of the 12 study procedure administrations with the Erchonia® FX-635™, the subject will record the following at the test site:

- ⌚ Visual Analog Scale (VAS) Degree of Pain Rating

POST-PROCEDURE ACTIVITIES

POST-PROCEDURE EVALUATION PHASE

The post-procedure administration evaluation phase of this study will commence immediately following completion of the procedure administration phase, and will last 3 months (about 12 weeks).

POST-PROCEDURE EVALUATION VISITS AND MEASURES

There will be 4 post-procedure evaluation visits. The first post-procedure evaluation visit will occur at the test site, and the remaining three post-procedure evaluation visits will take place at the subject's home. The subject will be provided with pre-dated case report forms on which to record the required information on each of those three post-procedure days, and a staff member at the investigator's test site will contact each individual on the designated day to remind him or her to record the required information. These visits, and the associated measures to be recorded at each visit, as listed and described, and according to the methodology outlined, in the STUDY TEST BATTERY section above are as follows:

DAILY MEASURES: AT HOME

The subject will continue to record all of the required information in the Subject Daily Diary, as applicable, at home, through to the 4 weeks post-procedure evaluation visit.

STUDY ENDPOINT EVALUATION: FOLLOWING COMPLETION OF THE PROCEDURE ADMINISTRATION PHASE: AT THE TEST SITE

The study endpoint evaluation visit will occur at the test site within one hour following completion of the procedure administration phase, after administration of the 12th and final procedure administration with the Erchonia® FX-635™.

The following measures will be recorded at this visit:

- 🕒 Visual Analog Scale (VAS) Degree of Pain Rating
- 🕒 Neuropathic Pain Symptom Inventory (NPSI)
- 🕒 Subject Satisfaction With Foot Pain Level
- 🕒 Subject Perceived Group Allocation and Rationale
- 🕒 Assessment Investigator Perceived Group Allocation and Rationale

TWO WEEKS POST-PROCEDURE EVALUATION: AT HOME

Two weeks following completion of the procedure administration phase, the following measures will be recorded:

- 🕒 Visual Analog Scale (VAS) Degree of Pain Rating

FOUR WEEKS POST-PROCEDURE EVALUATION: AT HOME

Four weeks following completion of the procedure administration phase, the following measures will be recorded:

- 🕒 Visual Analog Scale (VAS) Degree of Pain Rating
- 🕒 Neuropathic Pain Symptom Inventory (NPSI)
- 🕒 Subject Satisfaction With Foot Pain Level

THREE MONTHS POST-PROCEDURE EVALUATION: AT HOME

Three months following completion of the procedure administration phase, the following measures will be recorded:

- 🕒 Visual Analog Scale (VAS) Degree of Pain Rating
- 🕒 Neuropathic Pain Symptom Inventory (NPSI)
- 🕒 Subject Satisfaction With Foot Pain Level

OPEN-LABEL PLACEBO SUBJECT PROCEDURE ADMINISTRATION PERIOD

Following completion of the 3-month post-procedure administration phase, individual subject blinding will be broken. Subjects who had been randomized to the placebo (sham) procedure group will then be offered participation in an additional 6-week post-study open-label procedure administration period during which time they will knowingly receive the active 6-week 12-procedure administration protocol with the Erchonia® FX-635™ Laser as did the subjects initially assigned to the active test procedure group at the time of study enrollment.

A subject participating in the post-study open-label placebo subject procedure administration period will be required to:

- ✓ continue his or her required abstinence from use of non-study related medications and therapies for the relief of foot pain and the as-needed consumption of the study rescue medication (OTC Tylenol) for his or her foot pain, through to the end of the open-label placebo subject procedure administration period;
- ✓ record the same measures as during the initial procedure administration phase, as follows:

DAILY MEASURES

The subject will record all of the required information in the Subject Daily Diary, as applicable, at home.

FOLLOWING EACH PROCEDURE ADMINISTRATION

Within 10 minutes following administration of each of the post-study open-label procedure administration period 12 study procedure administrations with the Erchonia® FX-635™, the subject will record the following at the test site:

- 🕒 Visual Analog Scale (VAS) Degree of Pain Rating

STUDY ENDPOINT EVALUATION: FOLLOWING COMPLETION OF THE PROCEDURE ADMINISTRATION PHASE: AT THE TEST SITE

The post-study open-label procedure administration period study endpoint evaluation visit will occur at the test site within one hour following completion of the open-label procedure administration phase, after administration of the 12th and final procedure administration with the Erchonia® FX-635™.

The following measures will be recorded at this visit:

- 🕒 Visual Analog Scale (VAS) Degree of Pain Rating
- 🕒 Neuropathic Pain Symptom Inventory (NPSI)
- 🕒 Subject Satisfaction With Foot Pain Level

At completion of the post-study open-label procedure administration phase study endpoint evaluation test site visit, a subject's participation in the post-study open-label placebo subject procedure administration period will be complete. Subjects participating in the post-study open-label procedure administration phase will not be required to enter a post-procedure evaluation phase.

Participation in the 6-week post-study open-label procedure administration period is voluntary for subjects who had been assigned to the placebo (sham) procedure group. Participation in the 6-week post-study open-label procedure administration period will not be offered to subjects who had initially been randomized to the active test laser procedure group.

TABLE OF SUBJECT EVENTS

The following table provides a progressive summary of subject events throughout this study.

PRE-PROCEDURE ACTIVITIES
<ul style="list-style-type: none"> 🕒 A potentially well-suited and interested candidate for participation in the study attends the investigator's office. 🕒 The investigator reviews the informed consent form with the candidate. 🕒 If the candidate continues to be interested and voluntarily signs the informed consent form, the study qualification evaluation phase of the study is performed. 🕒 A qualified subject is randomly assigned to procedure group.
PRE-PROCEDURE WASHOUT PHASE: 48 HOURS
<ul style="list-style-type: none"> 🕒 Subject Daily Diary commenced 🕒 VAS Degree of Pain Rating (Daily)
PRE-PROCEDURE EVALUATION PHASE
<p>PRE-PROCEDURE VARIABLES</p> <ul style="list-style-type: none"> 🕒 Baseline Foot Variables 🕒 Baseline Concomitant Medication and Therapy Use 🕒 Subject Demographics <p>PRE-PROCEDURE MEASURES</p> <ul style="list-style-type: none"> 🕒 VAS Degree of Pain Rating 🕒 Neuropathic Pain Symptom Inventory (NPSI)
PROCEDURE ADMINISTRATION PHASE
<p>PROCEDURE ADMINISTRATION PROTOCOL</p> <p>Twelve 30-minute (15 minutes per foot) study procedure administrations with the Erchonia® FX-635™ over 6 consecutive weeks, 2 procedure administrations per week, administered at the test site.</p> <p>PROCEDURE ADMINISTRATION PHASE MEASURES</p> <ul style="list-style-type: none"> 🕒 Subject Daily Diary 🕒 VAS Degree of Pain Rating after each procedure administration

POST-PROCEDURE ACTIVITIES

DAILY MEASURES: AT HOME

- 🕒 Subject Daily Diary through to Week 4 Post-Procedure

STUDY ENDPOINT EVALUATION: AT TEST SITE

- 🕒 VAS Degree of Pain Rating
- 🕒 Neuropathic Pain Symptom Inventory (NPSI)
- 🕒 Subject Satisfaction With Foot Pain Level
- 🕒 Subject Perceived Group Allocation and Rationale
- 🕒 Assessment Investigator Perceived Group Allocation and Rationale

TWO WEEKS POST-PROCEDURE EVALUATION: AT HOME

- 🕒 VAS Degree of Pain Rating

FOUR WEEKS POST-PROCEDURE EVALUATION: AT HOME

- 🕒 VAS Degree of Pain Rating
- 🕒 Neuropathic Pain Symptom Inventory (NPSI)
- 🕒 Subject Satisfaction With Foot Pain Level

THREE MONTHS POST-PROCEDURE EVALUATION: AT HOME

- 🕒 VAS Degree of Pain Rating
- 🕒 Neuropathic Pain Symptom Inventory (NPSI)
- 🕒 Subject Satisfaction With Foot Pain Level

POST-STUDY OPEN-LABEL PLACEBO SUBJECT PROCEDURE ADMINISTRATION PERIOD

OPEN-LABEL PLACEBO SUBJECT PROCEDURE ADMINISTRATION PROTOCOL

Twelve 30-minute (15 minutes per foot) study procedure administrations with the Erchonia® FX-635™ over 6 consecutive weeks, 2 procedure administrations per week, administered at the test site.

OPEN-LABEL PROCEDURE ADMINISTRATION PHASE MEASURES

- 🕒 Subject Daily Diary
- 🕒 VAS Degree of Pain Rating after each procedure administration
- 🕒 Study Endpoint Evaluation:
 - ✓ VAS Degree of Pain Rating
 - ✓ Neuropathic Pain Symptom Inventory (NPSI)
 - ✓ Subject Satisfaction With Foot Pain Level

ADVERSE EVENTS

At each evaluation and measurement point throughout the clinical study, and at any other time throughout the duration of the clinical trial that is necessary, any and all potential adverse events reported by a subject or observed by an investigator will be recorded on the case report form, and subsequently evaluated by the investigator for its relation to the study procedure and whether or not any corrective action needs to be taken. All potential adverse events recorded will be appropriately reported to the governing IRB, as applicable.

It is unlikely and not expected that any adverse events will result from implementation of this clinical study protocol. Prior clinical trials using low level laser light have not typically yielded any adverse events or reactions. However, potential adverse events that may feasibly occur from application of the Erchonia® FX-635™ include, but are not necessarily limited to: skin irritation, discoloring, rash, indentations and infection.

PRIVACY AND CONFIDENTIALITY

Records for each subject in this clinical study will be maintained in separate files in a locked filing cabinet at the test site. The investigator at the test site will be responsible for ensuring that all records for a subject pertaining to his or her participation in the clinical study are stored in that subject's file at all times other than when information is being recorded on them.

Regulatory Insight, Inc., the study Monitor, will have access to the files for the purposes of data monitoring and auditing. Once the study is complete, copies of all of the subject case report forms will be made and supplied to Regulatory Insight, Inc. for analysis of results. Regulatory Insight, Inc. will maintain these copies in a separate clinical study file that is kept in a locked filing cabinet on their premises. The original records will be maintained at the respective test sites upon completion of the study in their original files and stored in a locked filing cabinet.

Subjects' identities will be kept confidential by assigning each subject a subject ID upon acceptance into the study. The subject ID will comprise the investigator's two initials (first and last name initials) and a three-digit number that will be based upon the subject's order of entry into the clinical study. Each test site will be assigned a unique range of numbers. Test site #1 will be assigned numbers 001 to 100. Test site #2 will be assigned numbers 101 to 200. For example, the eighth subject to be enrolled at test site #2 with Principal Investigator John Black would have a subject ID of JB108. Neither the study Sponsor nor Regulatory Insight, Inc. will receive any additional identifying information about a subject and will therefore have no way of linking a subject ID to a particular subject and his or her results.

MONITORING OF THE CLINICAL STUDY

The study Monitor will assure that each test site and each investigator is executing the protocol exactly as outlined and intended. This includes insuring that a signed informed consent form has been attained from each subject prior to commencing the protocol, and that all study evaluations are recorded using the specified methods and correctly and fully recorded on the appropriate clinical case report forms. All investigators will be trained by the same study Monitor to this end, including insuring that the investigator understands how to watch for, to evaluate and to handle, the occurrence or potential occurrence of an adverse event.

STATISTICAL ANALYSIS

PRIMARY EFFICACY OUTCOME MEASURE: CHANGE IN SUBJECT SELF-REPORTED VAS PAIN RATING FROM BASELINE TO STUDY ENDPOINT

Primary efficacy outcome measure for this clinical study will be a statistically significant difference in the proportion of subjects between test and control groups who achieve a clinically meaningful and statistically significant decrease in self-reported VAS pain rating from baseline to study endpoint.

The primary efficacy outcome evaluation will be performed on the blinded data attained from subjects who were initially enrolled in either the test or placebo procedure group, and will not include active procedure test data attained from placebo subjects who partook in the post-study open-label procedure administration period after blinding was broken.

Subjects meeting Individual Success Criteria

The individual subject success criteria is defined as a 30% or greater decrease in self-reported VAS pain rating at study endpoint relative to baseline.

Overall Study Success Criteria.

Overall study success criteria is defined as at least a 35% difference between procedure groups, comparing the proportion of individual successes in each group. It is anticipated that about 55% of subjects in the test group will meet the individual success criteria and about 20% of subjects in the control group will meet the individual success criteria.

The clinical relevance of a 30% change in VAS score has been well previously established by FDA's Division of Surgical, Orthopedic and Restorative Devices through numerous pre-IDE reviews, the results of said studies that were subsequently used to successfully support various pain-reduction related indications for various Erchonia Corporation light therapy devices under Product Code NHN for the 510(k)s listed below over the past 8 years:

1. K101430; 06/22/10: "The MLS-AC DermaScanner™ is indicated, while using the red diodes, for adjunctive use in providing temporary relief of minor chronic neck and shoulder pain of musculoskeletal origin."
2. K100509; 06/08/10: "The Erchonia THL1 is indicated for use in providing temporary relief of minor chronic neck and shoulder pain of musculoskeletal origin."
3. K072206; 04/24/08: "The Erchonia EML Laser is indicated for the temporary reduction in post - surgery pain at 24 hours after surgery following breast augmentation surgery."
4. K050672; 06/02/05: "The Erchonia EVRL Laser is generally indicated while using the red diode for adjunctive use in providing temporary relief of minor chronic neck and shoulder pain of musculoskeletal origin."
5. K041139; 09/30/04: "The Erchonia EML Laser is indicated as an adjunct to liposuction procedures of the thighs, hips and stomach for reduction of pain associated with the recovery process."

Evaluation Time Point

The study end evaluation time point at which primary study success will be analyzed is at six weeks post-baseline, following completion of the 12th and final study procedure administration with the Erchonia® FX-635™.

Null Hypothesis: There will be no statistically significant difference in the proportion of individual successes, as defined, between the test and control groups.

Alternative Hypothesis: There will be a statistically significant difference in the proportion of individual successes, as defined, between the test and control groups, to the effect of 35% or greater.

SECONDARY EFFICACY OUTCOME MEASURES

Secondary efficacy outcome measures will be evaluated for the following four data sets:

- (i) The blinded data set only attained from subjects who were initially enrolled in either the test or placebo procedure group, and will not include active procedure test data attained from placebo subjects who partook in the post-study open-label procedure administration period after blinding was broken.

For this group, the following secondary efficacy outcome measure will be evaluated:

- a) Change in VAS rating across and between all study evaluation time points within and between treatment groups
 - b) Change in scores on the Neuropathic Pain Symptom Inventory (NPSI) across and between all evaluation points within and between treatment groups
 - c) Differences in the use of rescue pain medication between procedure groups across study duration
- (ii) The combined data set comprising the blinded data set attained from subjects who were initially enrolled in either the test or placebo procedure group, and the active procedure test data attained from placebo subjects who partook in the post-study open-label procedure administration period after blinding was broken, comparing combined test (blinded and non-blinded) to placebo data

For this group, the following secondary efficacy outcome measure will be evaluated:

- a) Change in VAS rating across and between all study evaluation time points to study endpoint evaluation within and between treatment groups
 - b) Changes in scores on the Neuropathic Pain Symptom Inventory (NPSI) across and between all evaluation points to study endpoint evaluation within and between treatment groups
 - c) Differences in the use of rescue pain medication between procedure groups across study duration to study endpoint evaluation.
- (iii) The data set comprising the blinded data set attained from subjects who were initially enrolled in the test procedure group, and the active procedure test data attained from placebo subjects who partook in the post-study open-label procedure administration period after blinding was broken, comparing combined blinded to non-blinded test group data

For this group, the following secondary efficacy outcome measure will be evaluated:

- a) Change in VAS rating across and between all study evaluation time points to study endpoint evaluation within and between treatment groups
 - b) Changes in scores on the Neuropathic Pain Symptom Inventory (NPSI) across and between all evaluation points to study endpoint evaluation within and between treatment groups
 - c) Differences in the use of rescue pain medication between procedure groups across study duration to study endpoint evaluation.
- (iv) The data set comprising the blinded data set attained from subjects who were initially enrolled in the placebo procedure group, and the active procedure test data attained from placebo subjects who partook in the post-study open-label procedure administration period after blinding was broken, comparing combined blinded placebo to non-blinded test group data

For this group, the following secondary efficacy outcome measure will be evaluated:

- a) Change in VAS rating across and between all study evaluation time points to study endpoint evaluation within and between treatment groups
- b) Changes in scores on the Neuropathic Pain Symptom Inventory (NPSI) across and between all evaluation points to study endpoint evaluation within and between treatment groups
- c) Differences in the use of rescue pain medication between procedure groups across study duration to study endpoint evaluation.

In addition, the following will be explored:

- ✓ Any deviations in compliance with study required abstinences between procedure groups
 - ✓ Comments provided by subjects
 - ✓ Adverse events
- (v) The data set comprising the blinded data set attained from subjects who were initially enrolled in the test procedure group, and the active procedure test data attained from placebo subjects who partook in the post-study open-label procedure administration period after blinding was broken, comparing combined blinded to non-blinded test group data

For this group, the following secondary efficacy outcome measure will be evaluated:

- d) Change in VAS rating across and between all study evaluation time points to study endpoint evaluation within and between treatment groups
- e) Changes in scores on the Neuropathic Pain Symptom Inventory (NPSI) across and between all evaluation points to study endpoint evaluation within and between treatment groups
- f) Differences in the use of rescue pain medication between procedure groups across study duration to study endpoint evaluation.

STATISTICAL METHODS

Efficacy analysis will be according to the intent to treat (ITT) principle by last observation carried forward (LOCF).

Intent to Treat: Subjects will be included in the analysis if they were randomized to study procedure group, had a valid baseline visit including the required Low Back Pain VAS recordings; and received the first study procedure administration.

Last observation carried forward: Missing data will be handled by carrying forward the last observation.

Per-protocol analysis will also be performed for the set of all subjects who were randomized to procedure group and completed the study according to the full protocol.

STATISTICAL ANALYSIS

The primary analysis of efficacy will be through the application of:

- 1) **Fisher's exact test** to compare the proportion of success between the test and the control groups, considering that randomization has been diligently conducted and important covariates between the two groups are well balanced.
- 2) **Parametric ANCOVA model** analysis with the mean change from baseline to study endpoint in foot pain ratings on the VAS as the dependent variable, procedure group as the independent variable of interest and baseline average foot pain VAS rating as a covariate. A two-tailed significance level of 5% will be considered to be statistically significant.

Covariates: The following potential covariate baseline variables will be adjusted, as applicable, through application of an ANCOVA analysis for the continuous variables and linear regression analysis for categorical variables.

- ✓ Baseline VAS rating
- ✓ Baseline NPSI total score
- ✓ Duration of foot pain
- ✓ Time since Diabetes diagnosis
- ✓ Insulin dependent versus non-insulin dependent Diabetes
- ✓ Age
- ✓ Gender
- ✓ Ethnicity

Secondary Measures Analysis

- 🕒 The secondary measures that are continuous variables will be analyzed through parametric analysis using ANCOVA. A two-way significance level of 5% will be considered to be statistically significant.
- 🕒 The secondary measures that are categorical will be evaluated through linear regression analysis.

Satisfaction with Study Outcome Ratings: will be tabulated according to category and reported as percentages. Satisfaction levels will be correlated with subject individual study success and recorded changes in foot pain VAS ratings from Baseline to post-procedure evaluations.

BLINDING EFFICACY EVALUATION

Statistical evaluation of blinding efficacy will be performed as follows:

- (i) The percentage of subjects who correctly perceived their procedure group allocation and the percentage of subjects who did not correctly perceive their procedure group allocation will be calculated.
- (ii) The percentage of times the assessment investigator correctly perceived subjects' procedure group allocation and the percentage of times the assessment investigator did not correctly perceive subjects' procedure group allocation will be calculated.

- (iii) The Fischer's Exact categorical analysis technique for comparison of proportion of successes (accurate procedure group allocation determination) between actual active and placebo subject groups will be performed.

It is anticipated that the results of the Fischer's Exact analysis will not be statistically significant; that is, it is anticipated that both subjects assigned to the active procedure group and subjects assigned to the placebo procedure group will demonstrate a high percentage of accuracy of group allocation determination if the study treatment proves efficacious. Similarly, it is anticipated that assessment investigators will demonstrate a high percentage of accuracy of group allocation determination for both subjects assigned to the active procedure group and subjects assigned to the placebo procedure group, if the study treatment proves efficacious. Therefore, it should be noted that lack of a statistically significant Fischer's Exact analysis result will be considered an indicator of study blinding efficacy, providing additional support to study outcome efficacy, particularly if appropriately supported by the reasoning statements, as explained below.

Positive blinding efficacy will be supported by comments provided to support perceived group allocation that pertain to the determination being made based on treatment efficacy or lack thereof; e.g.: 'My foot pain is much less than it used to be, so I believe I got the real treatment' or 'My foot pain hasn't really changed, so I believe I got the fake treatment.'

Blinding will be determined to have failed if comments provided to support perceived group allocation pertain to factors such as sensation/visual clues (e.g. I saw/didn't see a light go on the laser, etc.) or other factors that pertain to blinding having been compromised such as 'I overheard the doctor saying I wasn't getting the real treatment.'

SAFETY ANALYSES

Safety analyses will be based on all subjects who were randomized to test or placebo procedure group. Safety will be assessed by evaluating and comparing frequency and incidence of observed and/or reported adverse events between test and placebo procedure groups related to administration of the Erchonia® FX-635™ laser procedures. A chi-square test with a continuity correction will be performed to compare the percentage of subjects who experienced adverse events between test and placebo procedure group subjects.

INDIVIDUAL SITE ANALYSIS

Analysis of results will be performed by individual test site and pooled across test sites. Application of a balanced test-control group study design incorporating a varied block by test site randomization procedure will contribute to statistical justification of pooling data across the different test sites.

INFORMED CONSENT

- Informed consent will be an agreement between the individual investigator and each subject, having the capacity to understand and make an informed decision. Consent will be obtained prior to each potential subject's participation in this clinical study.
- Each subject participating in this clinical study will be made aware of the fact that his or her participation involves research and the intent of the research, the expected duration of his or her participation and a description of the procedures that will be followed.
- Each subject will be made aware of the reasonably expected benefits he or she might receive, as well as any risks or potential discomfort that are involved.
- Each subject will also be made aware of alternative treatments available to him or her.
- Each subject will be made aware that his or her records will remain confidential, but that the FDA and the IRB has the right to inspect his or her records.
- Each subject will be told that his or her participation in the clinical study is voluntary, without force or influence from the investigator or sponsor.
- Each subject will be given the name and method of contacting the appropriate person(s) to answer his or her questions about the research and in the event of a research-related injury.

The subject informed consent form that will be used in this clinical study is contained in **Appendix E**.

CASE REPORT FORMS

The case report forms that will be used to collect the data from each subject in this clinical study can be found in **Appendix D**

APPENDIX E

INFORMED CONSENT FORM

RESEARCH SUBJECT INFORMATION AND CONSENT FORM

TITLE: A double-blind, placebo-controlled randomized evaluation of the effect of the Erchonia® FX-635™ on diabetic peripheral neuropathy pain clinical study

PROTOCOL NO.: None

SPONSOR: Erchonia Corporation

INVESTIGATOR:

SITE(S):

**STUDY-RELATED
PHONE NUMBER(S):**

This consent form may contain words that you do not understand. Please ask the study doctor or the study staff to explain any words or information that you do not clearly understand. You may take home an unsigned copy of this consent form to think about or discuss with family or friends before making your decision.

SUMMARY

You are being asked to be in a research study. The purpose of this consent form is to help you decide if you want to be in the research study. Please read this form carefully. To be in a research study you must give your informed consent. "Informed consent" includes:

- Reading this consent form,
- Having the study doctor or staff explain the research study to you,
- Asking questions about anything that is not clear, and
- Taking home an unsigned copy of this consent form. This gives you time to think about it and to talk to family or friends before you make your decision.

You should not join this research study until all of your questions are answered.

Things to know before deciding to take part in a research study:

- The main goal of a research study is to learn things to help patients in the future.
- The main goal of regular medical care is to help each patient.
- No one can promise that a research study will help you.
- Taking part in a research study is entirely voluntary. No one can make you take part.
- If you decide to take part, you can change your mind later on and withdraw from the research study.
- The decision to join or not join the research study will not cause you to lose any medical benefits. If you decide not to take part in this study, your doctor will continue to treat you.
- This study involves experimental (investigational) device procedures that are being tested for a certain condition or illness. An investigational device is one that has not been approved by the U.S. Food & Drug Administration (FDA).

After reading and discussing the information in this consent form you should know:

- Why this research study is being done;
- What will happen during the research;
- What device and procedures will be used;
- Any possible benefits to you;
- The possible risks to you;
- The other medical procedures, drugs or devices that could be used instead of being in this research study; and
- How problems will be treated during the study and after the study is over.

If you take part in this research study, you will be given a copy of this signed and dated consent form.

PURPOSE OF THE STUDY

In this study, the Sponsor, Erchonia Corporation, and investigators are studying the use of a device called the Erchonia® FX-635™ that gives off low level laser light. This study is to see if using the Erchonia® FX-635™ can help to reduce foot pain in people with diabetic peripheral neuropathy. The Erchonia® FX-635™ is cleared for marketing by the U.S. Food and Drug Administration (FDA) as an adjunct to reducing chronic heel pain arising from plantar fasciitis. However its use in this study is investigational, as the FX-635™ has not been cleared for market by the FDA for reducing foot pain in individuals with diabetic peripheral neuropathy.

PROCEDURES

- If you agree to take part in this study, you will be one of about 64 people taking part.
- This is a randomized, double-blind, placebo-controlled study. This means that if you choose to take part in this study, it will be determined by chance (like the flip of a coin) whether you will get the active study treatment or the placebo study treatment. In this study, there will be two groups of participants. Participants in one of the groups will get active study treatments. The other group of participants will get placebo treatments. This means the study treatments will be 'fake', as if the Erchonia® FX-635™ laser device were turned off.

Since there are two different groups, you have:

- About a 50% chance of receiving active study treatments.
- About a 50% chance of receiving a placebo treatment (no laser therapy).

Neither the active nor the placebo device make any noise or produce any heat, and both will have a light that you can see, so neither you nor the study investigators will be able to guess which group you are in.

To take part in this study, you must agree to not take any medicines or try any other treatments to help with your foot pain, until your part in the study is over. You may take over-the-counter Tylenol according to the directions for use on the labeling to help with your foot pain while in the study, if you need to.

- The study takes about four and a half months to complete.
- The study process is as follows:

Screening Visit (Visit 1)

If you are interested in taking part in this research study, we will conduct a screening visit at the test site. At this visit, we will review this consent form. Then, we will:

- Ask you to rate your foot pain on a line from 0-100, where '0' means you have no pain at all, and '100' means you have the worst pain imaginable.
- Get information about your medical history, including information about medical conditions you may have and medicines you may take

The visit should take about 15 minutes.

Washout Phase (at home)

The washout phase will start once you have successfully completed all of the screening procedures, and we can confirm that you are eligible for this study.

The washout phase occurs for 2 days after you have qualified for the study but before you get the first study treatment. On each of the 2 days of the washout phase, you will need to:

- Rate your foot pain on the same 0-100 line as you did during screening
- Start taking only Tylenol to relieve any foot pain you may have
- Write down each time you take a dose of Tylenol or any other medications you may take on those days for any reason.

Pre-Treatment Phase (Visit 2)

The pre-treatment phase will start once you have successfully completed the washout phase, and we can confirm that you continue to be eligible for this study. We will:

- Get information about the history of your foot pain and your diabetes
- Get information about medicines you are taking now for any reason
- Get information about your age, gender, and ethnicity
- Rate your foot pain on the same 0-100 line as you did during screening
- Ask you to fill out a questionnaire about different symptoms of your foot pain

The pre-treatment phase should take about 15 minutes.

Treatment Phase (Visits 2 through 13 and at home)

- The treatment phase will start after the pre-treatment phase is done, on the same day.
- There are 12 treatments with the Erchonia® FX-635™.
- The first treatment will happen on the same day as the pre-treatment phase.
- You will need to go to the test site 11 more times over 6 weeks for another treatment.
- Each treatment lasts 30 minutes, 15 minutes for each foot.
- You will sit comfortably with your foot elevated, and the Erchonia FX-635™ will be directed at 3 points on your foot. The laser light will shine on your foot, but it will not touch your skin.
- You will wear protective glasses to block out the laser light.
- On each day of the 6 weeks of the treatment phase, you will need to record some of the same measures at home as you did during the washout phase. You will need to:
 - Write down each time you take a dose of Tylenol to relieve any foot pain
 - Write down any other medications you take on those days for any reason that is different than usual.
- After each of the 12 treatments with the Erchonia® FX-635™, you will need to rate your foot pain on the same 0-100 line as you did during screening.

Post-Treatment Phase (Visit 13 and at home)

- The post-treatment phase will start right after your last treatment with the Erchonia® FX-635™ and last for three months.
- Right after your last treatment with the Erchonia® FX-635™, we will ask you to:
 - rate your foot pain on the same 0-100 line as you did during screening
 - fill out the questionnaire about different symptoms of your foot pain
 - rate how satisfied you are with any change you may have noticed in your foot pain after receiving the treatments with the Erchonia® FX635™ on a 5-point scale

- record if you think you got the treatments with the real or the fake Erchonia® FX635™ and why you think this
- For four weeks after your last treatment with the Erchonia® FX-465™, you will be asked to continue to use only over-the-counter Tylenol to help with any pain in your feet. You cannot take any other medication or try any other treatments to help with your foot pain during those four weeks. You will need to write down every time you take a dose of over-the-counter Tylenol during those four weeks, as you did during the washout and treatment phases.
- Two weeks after your last treatment with the Erchonia® FX-465™, you will again need to rate the level of pain in your feet on the 0 to 100 line, at home.
- Four weeks after your last treatment with the Erchonia® FX-465™, at home, you will again need to:
 - rate your foot pain on the same 0-100 line as you did during screening
 - fill out the questionnaire about different symptoms of your foot pain
 - rate how satisfied you are with any change you may have noticed in your foot pain after receiving the treatments with the Erchonia® FX635™ on a 5-point scale
- Three months after your last treatment with the Erchonia® FX-465™, at home, you will again need to:
 - rate your foot pain on the same 0-100 line as you did during screening
 - fill out the questionnaire about different symptoms of your foot pain
 - rate how satisfied you are with any change you may have noticed in your foot pain after receiving the treatments with the Erchonia® FX635™ on a 5-point scale

RISKS AND DISCOMFORTS

- There have been other research studies using Erchonia low level light lasers. In these studies, no serious medical events resulted from use of the study device.
- The only known or anticipated risk with the use of the laser study device is that long-term exposure to laser light could cause damage to your eyesight. As a precaution, when you are given the treatments with the FX-635™, you will be fitted with special darkened protective glasses to block out the light.
- However, there may be unknown risks to using the laser study device with this study treatment such as skin irritation, discoloring, rash, indentations and infection. There may be side effects that are not known at this time.
- It is possible that you will not get any improvement in your foot pain, or that it may even get worse.

PREGNANCY

If you are pregnant or nursing a child, you may not take part in this study. If you are trying to get pregnant, you should not volunteer for this study. Before entering the study, you and your study doctor must agree on the method of birth control you will use during the entire study. If you think that you have gotten pregnant during the study, you must tell your study doctor immediately, and you will be taken out of the study.

NEW INFORMATION

You will be told about any new information that might change your decision to be in this study. You may be asked to sign a new consent form if this occurs.

BENEFITS

Your foot pain may improve while you are in this study; however, this cannot be promised. The results of this study may help people to lessen their foot pain in the future.

COSTS

It will not cost you anything to be part of the study. Erchonia Corporation, the sponsor of this research, will provide the treatments with the Erchonia FX-635™ free of charge during this study. The cost for all study related procedures and measurements will also be covered by Erchonia Corporation. Nothing will be billed to you or to your insurance company.

PAYMENT FOR PARTICIPATION

You will not be paid for your part in this research study.

ALTERNATIVE TREATMENT

If you decide not to enter this study, there is other care available to you, such as over-the-counter medicines like aspirin, ibuprofen, naproxen, acetaminophen and capsaicin; topical creams such as lidocaine, salicylate and cortisone; prescription medications such as Celebrex, Lodine, and Relafen; antidepressants; anti-seizure drugs; opioid medicines, local anesthetic injections; surgical procedures; electrical nerve stimulation therapy; and hand or foot braces or orthopedic shoes. The study doctor will discuss these with you. You do not have to be in this study to be treated for your foot pain.

AUTHORIZATION TO USE AND DISCLOSE INFORMATION FOR RESEARCH PURPOSES

What information may be used and given to others?

The study doctor will get your personal and medical information. For example:

- Research records
- Records about your study visits.

Who may use and give out information about you?

The study doctor and the study staff.

Who might get this information?

The sponsor of this research. "Sponsor" means any persons or companies that are:

- working for or with the sponsor, or
- owned by the sponsor

Your information may be given to:

- The U.S. Food and Drug Administration (FDA),
- Department of Health and Human Services (DHHS) agencies,
- Governmental agencies in other countries,
- Western Institutional Review Board® (WIRB®).

Why will this information be used and/or given to others?

- to do the research,
- to study the results, and
- to see if the research was done right

If the results of this study are made public, information that identifies you will not be used.

What if I decide not to give permission to use and give out my health information?

Then you will not be able to be in this research study.

May I review or copy my information?

Yes, but only after the research is over.

May I withdraw or revoke (cancel) my permission?

Yes, but this permission will not stop automatically.

You may withdraw or take away your permission to use and disclose your health information at any time. You do this by sending written notice to the study doctor. If you withdraw your permission, you will not be able to stay in this study.

When you withdraw your permission, no new health information identifying you will be gathered after that date. Information that has already been gathered may still be used and given to others.

Is my health information protected after it has been given to others?

There is a risk that your information will be given to others without your permission.

A description of this clinical trial will be available on <http://www.ClinicalTrials.gov>, as required by U.S. Law. This Web site will not include information that can identify you. At most, the Web site will include a summary of the results. You can search this Web site at any time.

COMPENSATION FOR INJURY

If you are injured or get sick as a result of being in this study, call the study doctor immediately. The study doctor will provide emergency medical treatment. Your insurance will be billed for this treatment. The sponsor will pay any charges that your insurance does not cover. No other payment is routinely available from the study doctor or sponsor.

VOLUNTARY PARTICIPATION AND WITHDRAWAL

Your participation in this study is voluntary. You may decide not to participate or you may leave the study at any time. Your decision will not result in any penalty or loss of benefits to which you are entitled.

Your participation in this study may be stopped at any time by the study doctor or the sponsor without your consent for any of the following reasons:

- if it is in your best interest;
- you do not consent to continue in the study after being told of changes in the research that may affect you;
- or for any other reason

If you leave the study before the planned final visit, you may be asked by the study doctor to have some of the end of study procedures done.

SOURCE OF FUNDING FOR THE STUDY

The sponsor, Erchonia Corporation, will pay for this research study.

QUESTIONS

Contact <PI name> at <phone> (24 hours) for any of the following reasons:

- if you have any questions about this study or your part in it,
- if you feel you have had a research-related injury or a bad reaction to the study treatment,
or
- if you have questions, concerns or complaints about the research

If you have questions about your rights as a research subject or if you have questions, concerns or complaints about the research, you may contact:

Western Institutional Review Board® (WIRB®)
1019 39th Avenue SE Suite 120
Puyallup, Washington 98374-2115
Telephone: 1-800-562-4789 or 360-252-2500
E-mail: Help@wirb.com.

WIRB is a group of people who independently review research.

WIRB will not be able to answer some study-specific questions, such as questions about appointment times. However, you may contact WIRB if the research staff cannot be reached or if you wish to talk to someone other than the research staff.

Do not sign this consent form unless you have had a chance to ask questions and have gotten satisfactory answers.

If you agree to be in this study, you will receive a signed and dated copy of this consent form for your records.

CONSENT

I have read this consent form. All my questions about the study and my part in it have been answered. I freely consent to be in this research study.

I authorize the use and disclosure of my health information to the parties listed in the authorization section of this consent for the purposes described above.

By signing this consent form, I have not given up any of my legal rights.

Subject Name (printed)

CONSENT SIGNATURE:

Signature of Subject (18 years and older)

Date

Signature of Person Conducting Informed

Date