

## Protocol

**Study ID:** 207966

**Official Title of Study:** A Phase IIIb, Randomized, Multicenter, Parallel-group, Non-inferiority, Open-label Study Evaluating the Efficacy, Safety, and Tolerability of Long-acting Cabotegravir Plus Long-acting Rilpivirine Administered Every 8 Weeks or Every 4 Weeks in HIV-1-infected Adults who are Virologically Suppressed (ATLAS-2M), further referred to as A2M.

**NCTID:** NCT03299049

**Sub-study Protocol Amendment Title:** Sub-study to the A2M study to Evaluate the Pharmacokinetics, Tolerability and Efficacy of Cabotegravir and Rilpivirine Long-Acting Injections Following Intramuscular Administration in the Vastus Lateralis Muscle (thigh) in HIV-infected Adult Participants who have Received at Least Three Years of Gluteal Injections in the A2M Study.

**NCTID:** NCT05896761

**Date of Document:** 11 August 2021

The sub-study was added to the protocol of the main study via an amendment. Details of the sub-study can be found in the protocol section *11.13 Appendix 13: Vastus Lateralis Muscle (Thigh) PK sub-study Amendment*. A separate record has been created on ClinicalTrials.gov for the sub-study.

**TITLE PAGE**

**Protocol Title:** A Phase IIIb, Randomized, Multicenter, Parallel-group, Non-inferiority, Open-label Study Evaluating the Efficacy, Safety, and Tolerability of Long-acting Cabotegravir Plus Long-acting Rilpivirine Administered Every 8 Weeks or Every 4 Weeks in HIV-1-infected Adults who are Virologically Suppressed.

**Protocol Number:** 207966/06

**Short Title:** Study Evaluating the Efficacy, Safety, and Tolerability of Long-acting Cabotegravir Plus Long-acting Rilpivirine administered every 8 weeks in Virologically Suppressed HIV-1-infected Adults.

**Compound Number:** GSK1265744

**Sponsor Name and Legal Registered Address:**

This study is sponsored by ViiV Healthcare. GlaxoSmithKline is supporting ViiV Healthcare in the conduct of this study.

**Sponsor Legal Registered Address (excluding US):**

ViiV Healthcare UK Limited  
980 Great West Road  
Brentford  
Middlesex, TW8 9GS  
UK

**US IND Sponsor Legal Registered Address:**

ViiV Healthcare Company  
Five Moore Drive  
P.O. 13398  
Research Triangle Park, NC 27709-3398, USA  
Telephone: +1 919 438 2100

In some countries, local law requires that the Clinical Trial sponsor is a local company legal entity. In these instances, the appropriate company to be identified as Sponsor must be agreed with the global ViiV Healthcare clinical team and signed off by the Vice President, Global Research and Medical Strategy.

This study is sponsored by ViiV Healthcare. GlaxoSmithKline is supporting ViiV Healthcare in the conduct of this study

Copyright 2021 ViiV Healthcare group of companies. All rights reserved. Unauthorized copying or use of this information is prohibited.

**Regulatory Agency Identifying Number(s):**

IND No. 109,678;

EudraCT No. **2017-002946-62**

Approval Date: 11-Aug-2021

**SPONSOR SIGNATORY:**

**Protocol Title:** A Phase IIIb, Randomized, Multicenter, Parallel-group, Non-inferiority, Open-label Study Evaluating the Efficacy, Safety, and Tolerability of Long-acting Cabotegravir Plus Long-acting Rilpivirine Administered Every 8 Weeks or Every 4 Weeks in HIV-1-infected Adults who are Virologically Suppressed.

**Protocol Number:** 207966/06

**Compound Number:** GSK1265744

---

Scott McCallister,

---

**Date**

Head Physician, Clinical Development

ViiV Healthcare

**The signed page is a separate document.**

**Medical Monitor Name and Contact Information can be found in the Study Reference Manual**

## PROTOCOL AMENDMENT SUMMARY OF CHANGES TABLE

DOCUMENT HISTORY		
Document	Date	DNG Number
<i>Amendment 6</i>	11-Aug-2021	TMF-13901227
<i>Amendment 5</i>	16-Apr-2021	TMF-11797977
<i>Amendment 4</i>	05-Aug-2020	2017N326521_04
<i>Amendment 3</i>	21-May-2020	2017N326521_03
<i>Amendment 2</i>	03-Jul-2018	2017N326521_02
<i>Amendment 1</i>	14-Sep-2017	2017N326521_01
Original Protocol	17-Jul-2017	2017N326521_00

### Amendment 6 11-AUG-2021

#### Overall rationale for Amendment 6

The primary purposes of this amendment are:

- Included Thigh Injection Sub-study appendix
- Added safety and PK laboratory assessments during pregnancy for subjects who become pregnant during the study and decide to continue receiving IM treatment in the study.
- Medical device deficiencies reporting requirements updated to be aligned with GSK reporting processes.
- Updated safety information
- Other minor clarifications added

Section # and Name	Description of Change	Brief Rationale
Section 2.3.1 Risk assessment	<ul style="list-style-type: none"> <li>Updated animal reproduction data changed in line with CAB IB, to ensure the most up to date data is used</li> <li>Information regarding systemic reactions following RPV LA injection updated</li> <li>Removal of "CAB is in clinical development"</li> <li>Changed text from " a small proportion of" to "less than 1%" of participants have developed transaminitis</li> <li>Removal of text regarding participants with suspected DILI only receiving oral cabotegravir</li> </ul>	<ul style="list-style-type: none"> <li>Clarification requested by Korean Reg Agency to align with IB exposure range</li> <li>Safety information update CAB is now marketed in some countries</li> <li>More accurate data using "less than 1%"</li> <li>Some DILI were identified in participants taking prep (LA CAB)</li> </ul>
4.2.4 LTFU Phase	<ul style="list-style-type: none"> <li>Additional clarification provided on participants who transition to commercial product and do not enter the LTFU phase that the transition plan to marketed product should be done in consultation with the Central Study Team and study Medical Monitor</li> </ul>	<ul style="list-style-type: none"> <li>As more countries begin to transition their participants onto commercial CAB + RPV LA this additional information provides more guidance for investigators</li> </ul>
5.3 Additional eligibility criteria	<ul style="list-style-type: none"> <li>Additional clarification regarding participants in CAB studies being unable to participate in other clinical studies</li> </ul>	<ul style="list-style-type: none"> <li>Study teams were seeing a rise in requests for participants being involved in other interventional studies, the additional text clarifies that this is not permitted in CAB protocols</li> </ul>
7.1.1 and 7.2.2 Time and Events table	<ul style="list-style-type: none"> <li>Added Device Deficiencies reporting assessment</li> </ul>	<ul style="list-style-type: none"> <li>In line with Medical Device Reporting requirement.</li> </ul>
7.4.3.1. Time period and Frequency for collecting AE and SAE information	<ul style="list-style-type: none"> <li>Updated medical device text to now use the term "associated person" and "authorization letter"</li> </ul>	<ul style="list-style-type: none"> <li>In line with GSK reporting processes</li> </ul>
7.4.3.4 Prompt Reporting of SAEs and Other Events	<ul style="list-style-type: none"> <li>Added footer reference to Appendix 12 for Medical Device deficiencies reporting requirements</li> </ul>	<ul style="list-style-type: none"> <li>In line with GSK reporting processes</li> </ul>
7.4.3.5 Disease related events and / or Disease Related Outcomes not Qualifying as SAEs	<ul style="list-style-type: none"> <li>Updated text in this section to ensure the reporting process is in line with the study reporting process and data management</li> <li>Removed "instead of a DRE"</li> </ul>	<ul style="list-style-type: none"> <li>Removes confusion and is in line with ATLAS2M reporting</li> </ul>
7.4.3.9 Medical device deficiencies	<ul style="list-style-type: none"> <li>Updated medical device text to now use the term "associated person" and "authorization letter"</li> <li>Included examples of who an "associated person" is</li> <li>Updated text to clarify the process for an associated person</li> <li>Updated wording on the medical devices used in the study</li> <li>Included wording regarding the responsible person for compliance with local regulatory requirements relating to the reporting of device deficiencies</li> </ul>	<ul style="list-style-type: none"> <li>In line with GSK reporting processes</li> <li>Provides clarity on what is considered a medical device</li> </ul>

Section # and Name	Description of Change	Brief Rationale
7.4.5.4 Seizures	<ul style="list-style-type: none"> <li>Updated statistics regarding seizures following CAB administration</li> </ul>	<ul style="list-style-type: none"> <li>Provides the most up to date information</li> </ul>
7.4.7.3 Time Period for Collecting Pregnancy Information	<ul style="list-style-type: none"> <li>Additional text regarding women who become pregnant whilst on LA and the collection of unbound CAB and extra testing during pregnancy, this is updated through the pregnancy appendix</li> </ul>	<ul style="list-style-type: none"> <li>In line with updated requirements to ensure clinical oversight of pregnant subjects</li> </ul>
7.4.7.4 Action to be Taken if Pregnancy Occurs	<ul style="list-style-type: none"> <li>Additional text to clarify the additional samples to be collected in case of pregnancy.</li> </ul>	<ul style="list-style-type: none"> <li>In line with updated requirements to ensure clinical oversight of pregnant subjects.</li> </ul>
11.1 Appendix 1: Abbreviations and Trademarks	<ul style="list-style-type: none"> <li>Added new abbreviations and trademarks used throughout the protocol.</li> </ul>	<ul style="list-style-type: none"> <li>Not applicable</li> </ul>
11.6.5. Evaluating AEs and SAEs	<ul style="list-style-type: none"> <li>Added language regarding Medical Device deficiency reporting</li> </ul>	<ul style="list-style-type: none"> <li>In line with Medical Device Reporting requirement.</li> </ul>
11.8.3 Informed Consent Process	<ul style="list-style-type: none"> <li>Updated medical device text to now use the term "associated person" and "authorization letter"</li> </ul>	<ul style="list-style-type: none"> <li>In line with GSK reporting processes</li> </ul>
11.11.3 Background (Removed)	<ul style="list-style-type: none"> <li>Removed this section as pregnancy outcome details were no longer current.</li> </ul>	<ul style="list-style-type: none"> <li>Safety information update.</li> </ul>
11.11.3.1 Cabotegravir	<ul style="list-style-type: none"> <li>Updated animal reproduction data changed in line with CAB IB, to ensure the most up to date data is used</li> <li>Updated text regarding the ongoing DTG birth outcomes study to provide the most up to date data</li> <li>Removal of outdated text</li> </ul>	<ul style="list-style-type: none"> <li>Clarification requested by Korean Reg Agency to align with IB exposure range</li> <li>Safety information update</li> </ul>
11.11.4.3 Overall Benefit: Risk Conclusion	<ul style="list-style-type: none"> <li>Pregnancy appendix summary updated</li> </ul>	<ul style="list-style-type: none"> <li>In line with updated requirements to ensure clinical oversight of pregnant subjects.</li> </ul>
11.11.4.1 Exposure	<ul style="list-style-type: none"> <li>Additional text to clarify the additional samples to be collected in case of pregnancy.</li> </ul>	
11.11.5 Study Assessments and Procedures: specific assessments for pregnant participants		
11.11.5.1. Safety Assessment	<ul style="list-style-type: none"> <li>Mentioned that samples will be obtained for HIV-1 RNA and Clinical chemistry from the pregnant participants electing to continue the study</li> </ul>	<ul style="list-style-type: none"> <li>Additional safety assessments for pregnant participants</li> </ul>
11.11.5.2. Pharmacokinetics	<ul style="list-style-type: none"> <li>Added the details on PK sample collections separately for CAB and RPV, and unbound concentrations.</li> </ul>	<ul style="list-style-type: none"> <li>Provided the detailed information</li> </ul>
11.12.1 Definition of Device deficiency	<ul style="list-style-type: none"> <li>Updated definition of Device Deficiency</li> </ul>	<ul style="list-style-type: none"> <li>In line with GSK reporting processes</li> </ul>
11.12.2 Recording and Follow-Up of	<ul style="list-style-type: none"> <li>Updated AE, SAE and Device Deficiency recording</li> </ul>	

Section # and Name	Description of Change	Brief Rationale
AE and/or SAE and Device Deficiencies		
11.12.4 Reporting of Medical Device Deficiencies for Associated Person	<ul style="list-style-type: none"> <li>• Updated medical device text to now use the term "associated person" and "authorization letter"</li> <li>• Included examples of who is an "associated person"</li> </ul>	<ul style="list-style-type: none"> <li>• In line with the current process of using an authorization letter if an associated person is impacted by a medical device in study</li> <li>• Informs investigators of who is considered an "associated person"</li> </ul>
11.13 Appendix 13 Thigh PK sub study	<ul style="list-style-type: none"> <li>• Included the Appendix: Vastus Lateralis Muscle (Thigh) PK sub study amendment. The appendix includes all of the relevant information for the sub study.</li> </ul>	<ul style="list-style-type: none"> <li>• ATLAS2M Thigh PK Sub-study implementation.</li> </ul>
General Updates	<ul style="list-style-type: none"> <li>• Additional minor clarifications and corrections to typographical errors/formatting to protocol text have been added</li> </ul>	<ul style="list-style-type: none"> <li>• Text clarifications and formatting</li> </ul>



**TABLE OF CONTENTS**

	<b>Page</b>
PROTOCOL AMENDMENT SUMMARY OF CHANGES TABLE.....	4
1. SYNOPSIS.....	16
1.1. Rationale .....	16
1.2. Objectives and Endpoints .....	17
1.3. Overall Design .....	19
1.3.1. 207966 (ATLAS-2M) Study Design Schematic .....	21
1.3.2. Number of Participants .....	21
1.4. Treatment Groups and Duration .....	22
1.4.1. Screening Phase (Up to 35 days) .....	22
1.4.2. Maintenance Phase (Day 1 up to Week 100).....	22
1.4.2.1. Patients randomized to LA dosing from current ART SOC therapy:.....	23
1.4.2.1.1. IM injections every 4 weeks (Q4W from SOC): .....	24
1.4.2.1.2. IM injections every 8 weeks (Q8W from SOC): .....	24
1.4.2.2. Participants transitioning from ATLAS and currently receiving CAB LA + RPV LA Q4W .....	25
1.4.2.2.1. IM injections every 4 weeks (Q4W from ATLAS Q4W):.....	26
1.4.2.2.2. IM injections every 8 weeks (Q8W from ATLAS Q4W):.....	26
1.4.3. Extension Phase.....	26
1.4.4. Long-Term Follow-Up Phase .....	27
1.4.5. Dose Modifications: .....	29
2. INTRODUCTION.....	29
2.1. Study Rationale .....	30
2.2. Background .....	30
2.3. Benefit/Risk Assessment .....	33
2.3.1. Risk Assessment .....	33
2.3.1.1. Other Clinically Relevant Information.....	50
2.3.2. Benefit Assessment .....	50
2.3.3. Overall Benefit:Risk Conclusion .....	50
3. OBJECTIVES AND ENDPOINTS.....	51
4. STUDY DESIGN .....	54
4.1. Overall Design .....	54
4.2. Treatment Groups and Duration .....	56
4.2.1. Screening Phase (Up to 35 days) .....	56
4.2.2. Maintenance Phase (Day 1 up to Week 100).....	57
4.2.2.1. Patients randomized to LA dosing from current ART SOC therapy:.....	58
4.2.2.1.1. IM injections every 4 weeks (Q4W from SOC): .....	59

- 4.2.2.1.2. IM injections every 8 weeks (Q8W from SOC): ..... 59
- 4.2.2.2. Participants transitioning from ATLAS and currently receiving CAB LA + RPV LA Q4W ..... 60
  - 4.2.2.2.1. IM injections every 4 weeks (Q4W from ATLAS Q4W):..... 60
  - 4.2.2.2.2. IM injections every 8 weeks (Q8W from ATLAS Q4W):..... 60
- 4.2.3. Extension Phase..... 61
- 4.2.4. LTFU Phase – IM Regimen Only ..... 62
- 4.2.5. Dose Modifications: ..... 63
- 4.2.6. Independent Data Monitoring Committee..... 63
- 4.3. Type and Number of Participants..... 64
- 4.4. Scientific Rationale for Study Design ..... 64
- 4.5. Dose Justification..... 66
  - 4.5.1. Oral Lead-In Phase..... 66
  - 4.5.2. Long Acting Injectable for Maintenance Phase ..... 69
    - 4.5.2.1. CAB LA Q8W ..... 73
      - 4.5.2.1.1. CAB PK Profile Following Transition to Q8W Regimen..... 73
    - 4.5.2.2. CAB LA Q4W ..... 76
  - 4.5.3. RPV LA..... 78
    - 4.5.3.1. RPV LA Q8W ..... 79
      - 4.5.3.1.1. RPV PK Profile Following Transition to Q8W Regimen..... 80
    - 4.5.3.2. RPV LA Q4W ..... 83
- 5. SELECTION OF STUDY POPULATION AND WITHDRAWAL CRITERIA ..... 85
  - 5.1. Inclusion Criteria ..... 85
  - 5.2. Exclusion Criteria..... 88
  - 5.3. Additional Eligibility Criteria..... 92
  - 5.4. Screening/Baseline/Run-in Failures ..... 93
  - 5.5. Withdrawal/Stopping Criteria..... 93
    - 5.5.1. Liver Chemistry Stopping Criteria ..... 96
      - 5.5.1.1. Liver Chemistry Stopping Criteria, Participant Management and Follow-Up..... 97
      - 5.5.1.2. Liver Event Adjudication Committee ..... 98
      - 5.5.1.3. Liver Chemistry Stopping Criteria – Restart..... 98
      - 5.5.1.4. General Guidance Restart..... 99
        - 5.5.1.4.1. Drug Restart ..... 99
        - 5.5.1.4.2. Drug Restart Following Transient Resolving Liver Events Not Related to IP..... 100
    - 5.5.2. QTc Stopping Criteria ..... 101
    - 5.5.3. Virologic Failure ..... 102
    - 5.5.4. Definition of Protocol-Defined Confirmed Virologic Failure..... 102
    - 5.5.5. Managing Virologic Failure ..... 102
      - 5.5.5.1. HIV-1 RNA Blips..... 102
      - 5.5.5.2. Suspected Virologic Failure ..... 103
      - 5.5.5.3. Confirmed Virologic Failure ..... 103
  - 5.6. Participant and Study Completion..... 104

- 6. STUDY TREATMENT ..... 105
  - 6.1. Investigational Product and Other Study Treatment..... 105
    - 6.1.1. Formulations of CAB + RPV ..... 106
      - 6.1.1.1. Cabotegravir Tablets (CAB)..... 106
      - 6.1.1.2. Rilpivirine Tablets (RPV)..... 106
      - 6.1.1.3. Cabotegravir Injectable Suspension (CAB LA) ..... 106
      - 6.1.1.4. Rilpivirine Injectable Suspension (RPV LA) ..... 106
  - 6.2. Treatment Assignment..... 107
  - 6.3. Dosage and Administration ..... 107
  - 6.4. Blinding..... 110
  - 6.5. Packaging and Labeling..... 110
  - 6.6. Preparation/Handling/Storage/Accountability ..... 110
    - 6.6.1. Dosing Considerations for CAB LA + RPV LA..... 111
  - 6.7. Compliance with Study Treatment Administration ..... 112
  - 6.8. Protocol Permitted Substitutions ..... 113
    - 6.8.1. Oral Bridging..... 113
  - 6.9. Interruption of Study Treatment and Visit/Dosing Windows ..... 113
    - 6.9.1. IM Dosing ..... 113
      - 6.9.1.1. IM injections every 4 weeks (Q4W): ..... 114
      - 6.9.1.2. IM injections every 8 weeks (Q8W): ..... 115
      - 6.9.1.3. IM injections every 4 weeks (Q4W) (Q4W from ATLAS Q4W):..... 116
      - 6.9.1.4. IM injections every 8 weeks (Q8W) (Q8W from ATLAS Q4W):..... 116
    - 6.9.2. Oral Dosing..... 116
  - 6.10. Discontinuation of Study Treatment ..... 117
  - 6.11. Treatment of Study Treatment Overdose ..... 117
  - 6.12. Treatment after the End of the Study ..... 118
  - 6.13. Concomitant Medications and Non-Drug Therapies..... 118
    - 6.13.1. Permitted Medications and Non-Drug Therapies..... 119
    - 6.13.2. Prohibited Medications and Non-Drug Therapies ..... 119
      - 6.13.2.1. Concurrent with CAB and/or RPV ..... 120
      - 6.13.2.2. Concurrent with either CAB LA or RPV LA ..... 121
      - 6.13.2.3. Prohibited Medications for Participants Receiving HAART during the Long-Term Follow-Up Phase ..... 121
  - 6.14. Medical Devices..... 121
- 7. STUDY ASSESSMENTS AND PROCEDURES ..... 122
  - 7.1. Time and Events Table ..... 122
    - 7.1.1. Time and Events Table for CAB LA + RPV LA Q4 Weekly Administration..... 123
    - 7.1.2. Time and Events Table for CAB LA + RPV LA Q8 Weekly Administration..... 131
  - 7.2. Screening and Critical Baseline Assessments ..... 137
    - 7.2.1. Screening Assessments ..... 137
    - 7.2.2. Baseline Assessments..... 138
  - 7.3. Efficacy..... 139
    - 7.3.1. Plasma HIV-1 RNA ..... 139
    - 7.3.2. Lymphocyte Subsets, CD4+ and CD8+ ..... 139
    - 7.3.3. HIV Associated Conditions ..... 139
  - 7.4. Safety ..... 140

7.4.1.	Clinical Evaluations.....	140
7.4.2.	Laboratory Assessments .....	141
7.4.3.	Adverse Events (AE) and Serious Adverse Events (SAEs).....	144
7.4.3.1.	Time period and Frequency for collecting AE and SAE information.....	144
7.4.3.2.	Method of Detecting AEs and SAEs .....	144
7.4.3.3.	Follow-up of AEs and SAEs.....	145
7.4.3.4.	Prompt Reporting of Serious Adverse Events and Other Events .....	145
7.4.3.5.	Disease-Related Events and/or Disease- Related Outcomes Not Qualifying as SAEs .....	148
7.4.3.6.	Regulatory Reporting Requirements for SAEs.....	148
7.4.3.7.	Cardiovascular and Death Events .....	149
7.4.3.8.	Death Events.....	149
7.4.3.9.	Medical Device Deficiencies .....	150
7.4.3.9.1.	Time period for Detecting Medical Device Deficiencies .....	150
7.4.3.9.2.	Follow-up of Medical Device Deficiencies .....	150
7.4.3.9.3.	Prompt Reporting of Medical Device Deficiencies to the Sponsor .....	150
7.4.3.9.4.	Regulatory Reporting Requirements for Device Deficiencies .....	151
7.4.4.	Toxicity Management.....	151
7.4.4.1.	Treatment Interruption Due to an Adverse Event.....	151
7.4.4.2.	Grade 1 or Grade 2 Toxicity/Adverse Event .....	152
7.4.4.3.	Grade 3 Toxicity/Adverse Event .....	152
7.4.4.4.	Grade 4 Toxicity/Adverse Event .....	153
7.4.5.	Specific Toxicities/Adverse Event Management.....	153
7.4.5.1.	Liver Chemistry Stopping and Follow-up Criteria.....	153
7.4.5.2.	Diarrhea .....	153
7.4.5.3.	Hypertriglyceridemia/ Hypercholesterolemia.....	154
7.4.5.4.	Seizures .....	154
7.4.5.5.	Creatine Phosphokinase (CPK) Elevation .....	155
7.4.5.6.	Lipase Elevations and Pancreatitis .....	155
7.4.5.7.	Decline in Renal Function.....	156
7.4.5.7.1.	Proximal Renal Tubule Dysfunctions (PRTD).....	157
7.4.5.8.	Proteinuria.....	157
7.4.5.9.	QTc Prolongation .....	157
7.4.5.10.	Injection Site Reactions (ISRs) .....	158
7.4.5.11.	Allergic reaction.....	158
7.4.5.12.	Abacavir Hypersensitivity Reaction (ABC HSR).....	158
7.4.5.12.1.	Essential Patient Information .....	159
7.4.5.12.2.	Reporting of Hypersensitivity Reactions .....	160
7.4.5.13.	Rash Without ABC HSR Symptoms .....	160
7.4.6.	Suicidal Risk Monitoring.....	162

7.4.7.	Pregnancy .....	162
7.4.7.1.	Pregnancy testing.....	162
7.4.7.2.	Rationale for Continued Use in Pregnancy .....	163
7.4.7.3.	Time Period for Collecting Pregnancy Information .....	163
7.4.7.4.	Action to be Taken if Pregnancy Occurs.....	164
7.4.8.	Physical Exams .....	165
7.4.9.	Vital Signs.....	165
7.4.10.	Electrocardiogram (ECG).....	165
7.5.	Pharmacokinetics .....	165
7.5.1.	PK Sample Collection .....	166
7.5.2.	Rationale of PK Sampling Strategy .....	168
7.5.3.	Sample Analysis .....	168
7.5.3.1.	CAB Sample Analysis.....	168
7.5.3.2.	RPV Sample Analysis.....	168
7.6.	Genetics .....	168
7.7.	Viral Genotyping and Phenotyping.....	168
7.7.1.	HIV-1 Polymerase Viral Genotyping and Phenotyping .....	169
7.7.2.	HIV-1 Exploratory Analysis .....	169
7.8.	Value Evidence and Outcomes.....	169
7.8.1.	Value Evidence and Outcomes Endpoints (Secondary).....	171
7.8.2.	Value Evidence and Outcomes Endpoints (Exploratory).....	171
7.8.3.	Guidance for administering the different versions of HIVTSQc, Preference and Reason for Switch Questionnaires in ATLAS-2M.....	172
8.	DATA MANAGEMENT .....	173
9.	STATISTICAL CONSIDERATIONS AND DATA ANALYSES .....	174
9.1.	Sample Size Considerations .....	174
9.1.1.	Rationale for non-inferiority margin .....	174
9.1.2.	Assumption for Snapshot Proportion with HIV-RNA $\geq 50$ c/mL at Week 48 (Primary Endpoint) .....	175
9.1.3.	Assumption for Response Rate at Week 48 (Secondary Endpoint) .....	175
9.1.4.	Sample Size Sensitivity.....	175
9.1.5.	Sample Size Re-estimation or Adjustment.....	177
9.2.	Data Analysis Considerations .....	177
9.2.1.	Analysis Populations.....	177
9.2.1.1.	Intent-to-Treat Exposed (ITT-E).....	177
9.2.1.2.	Per-Protocol Population (PP).....	177
9.2.1.3.	PK Population.....	177
9.2.1.4.	Safety Population .....	178
9.2.2.	Treatment Comparisons .....	178
9.2.2.1.	Primary Comparison of Interest .....	178
9.2.2.2.	Other Comparisons of Interest.....	178
9.2.3.	Planned Analyses .....	178
9.2.3.1.	Week 24 data analyses .....	179
9.2.3.2.	IDMC analyses .....	179
9.3.	Key Elements of Analysis Plan .....	179
9.3.1.	Primary Analyses.....	179
9.3.2.	Secondary Analyses .....	181

9.3.2.1.	Key Secondary Efficacy Analysis.....	181
9.3.2.2.	Other Secondary Endpoint Analyses .....	181
9.3.3.	Pharmacokinetic Analyses.....	182
9.3.4.	Population PK Analysis:.....	183
9.3.5.	Pharmacokinetic/Pharmacodynamic Analyses.....	183
9.3.6.	Viral Genotyping/Phenotyping Analyses .....	183
9.3.7.	Health Outcomes Analyses.....	183
9.3.8.	Genetic Analyses.....	184
9.3.9.	Other Analyses .....	184
10.	REFERENCES.....	185
11.	APPENDICES .....	189
11.1.	Appendix 1: Abbreviations and Trademarks.....	189
11.2.	Appendix 2: Division of AIDS Table for Grading the Severity of Adult and Pediatric Adverse Events Version 2.1, March 2017.....	193
11.3.	Appendix 3: Liver Safety – Required actions, Follow up Assessments and Study Treatment Restart Guidelines .....	217
11.3.1.	VSLC Guidelines for Drug Restart after stop for Liver criteria.....	217
11.3.2.	VSLC Decision Process for Drug Restart Approval or Disapproval.....	217
11.3.3.	Medical monitor, GCSP Physician and PI actions for Restart following VSLC decision .....	219
11.3.3.1.	Medical Monitor and GCSP Physician Actions.....	219
11.3.3.2.	PI Actions: .....	220
11.4.	Appendix 4: CDC Classification for HIV-1 Infection (2014).....	221
11.5.	Appendix 5: Genetic Research .....	223
11.6.	Appendix 6: Definition of and Procedures for Recording, Evaluating, Follow-Up and Reporting of Adverse Events.....	226
11.6.1.	Definition of Adverse Events .....	226
11.6.2.	Definition of Serious Adverse Events .....	227
11.6.3.	Definition of Cardiovascular Events .....	229
11.6.4.	Recording of AEs and SAEs .....	229
11.6.5.	Evaluating AEs and SAEs.....	230
11.6.6.	Reporting of SAEs to GSK.....	231
11.7.	Appendix 7: Contraceptive Guidance and Collection of Pregnancy Information.....	233
11.7.1.	Collection of Pregnancy Information .....	235
11.8.	Appendix 8: Study governance Considerations.....	236
11.8.1.	Regulatory and Ethical Considerations, Including the Informed Consent Process .....	236
11.8.2.	Financial Disclosure.....	236
11.8.3.	Informed Consent Process .....	237
11.8.4.	Data Protection.....	237
11.8.5.	Independent Data Monitoring Committee.....	238
11.8.6.	Quality Control (Study Monitoring) .....	238
11.8.7.	Data Quality Assurance .....	238
11.8.8.	Source Documents .....	239
11.8.9.	Study and Site Closure .....	239
11.8.10.	Records Retention .....	240

- 11.8.11. Provision of Study Results to Investigators, Posting of Information on Publicly Available Clinical Trials Registers and Publication ..... 241
- 11.9. Appendix 9: Country-Specific Requirements ..... 242
  - 11.9.1. Study Duration ..... 242
- 11.10. Appendix 10: COVID-19 Pandemic and Clinical Trial Continuity ..... 243
  - 11.10.1. Changes to Study Visits and Study Procedures ..... 243
  - 11.10.2. Changes to Informed Consent ..... 244
  - 11.10.3. Permissible Use of Antiretroviral Therapy ..... 244
  - 11.10.4. Direct-To-Patient (DTP) Shipment of Oral Study IP ..... 246
  - 11.10.5. COVID-19 Experimental Agents ..... 247
  - 11.10.6. COVID-19 Specific Data Capture ..... 247
    - 11.10.6.1. Capturing COVID-19 Specific Protocol Deviations ..... 247
    - 11.10.6.2. Capturing COVID-19 Specific AEs and SAEs ..... 247
- 11.11. Appendix 11: Information and Guidance for Managing Pregnant Participants ..... 250
  - 11.11.1. Collection of Pregnancy Information ..... 250
  - 11.11.2. Introduction ..... 250
  - 11.11.3. Benefit/Risk Assessment ..... 251
    - 11.11.3.1. Cabotegravir ..... 251
    - 11.11.3.2. Rilpivirine ..... 254
  - 11.11.4. Clinical Considerations ..... 254
    - 11.11.4.1. Exposure ..... 254
    - 11.11.4.2. Use of Supplements with CAB + RPV LA ..... 256
      - 11.11.4.2.1. Oral Cabotegravir Only ..... 256
    - 11.11.4.3. Overall Benefit: Risk Conclusion ..... 256
  - 11.11.5. Study Assessments and Procedures: specific assessments for pregnant participants ..... 257
    - 11.11.5.1. Safety Assessments ..... 257
    - 11.11.5.2. Pharmacokinetics ..... 258
  - 11.11.6. References ..... 258
- 11.12. Appendix 12: Device Deficiencies: Definition and Procedures for Recording, Evaluating, Follow-up, and Reporting in Medical Device Studies ..... 260
  - 11.12.1. Definition of Device Deficiency ..... 260
  - 11.12.2. Recording and Follow-Up of AE and/or SAE and Device Deficiencies ..... 260
  - 11.12.3. Reporting of Medical Device Deficiencies for participants ..... 261
  - 11.12.4. Reporting of Medical Device Deficiencies for Associated Person ..... 262
- 11.13. Appendix 13: Vastus Lateralis Muscle (Thigh) PK sub-study Amendment ..... 263
  - 11.13.1. Sub-study Amendment Background ..... 263
  - 11.13.2. Sub-study Amendment rationale ..... 265
  - 11.13.3. Sub-study Amendment: Objectives and Endpoints ..... 266
  - 11.13.4. Sub-study Amendment Design ..... 268
    - 11.13.4.1. Sub-study Amendment: Inclusion and Exclusion Criteria ..... 269
      - 11.13.4.1.1. Sub-study Inclusion Criteria ..... 269
      - 11.13.4.1.2. Sub-study Exclusion Criteria ..... 269
    - 11.13.4.2. Screening Phase (Gluteal IM) ..... 273

- 11.13.4.3. Thigh injections Phase (16 weeks) .....273
- 11.13.4.4. Return to Gluteal Injection Phase .....274
- 11.13.4.5. Sub-study completion .....275
- 11.13.4.6. Sub-study Amendment Withdrawal/Stopping  
Criteria.....276
  - 11.13.4.6.1. Sub-study Amendment Specific  
Virologic Failure Guidance .....276
  - 11.13.4.6.2. Sub-study Amendment HIV-1  
RNA Blips Guidance .....276
  - 11.13.4.6.3. Sub-study Amendment Specific  
Withdrawal Criteria - Pregnancy .....276
- 11.13.5. Sub-study: Time and Events table .....277
  - 11.13.5.1. Sub-study: Time and Events Table for CAB LA  
+ RPV LA Q4 Weekly Administration .....277
  - 11.13.5.2. Sub-study: Time and Events Table for CAB LA  
+ RPV LA Q8 Weekly Administration .....282
  - 11.13.5.3. Sub-study: Value Evidence and Outcomes.....286
  - 11.13.5.4. Sub-study: Pharmacokinetics sample collection .....287
- 11.13.6. Sub-study Amendment: Study Treatment .....287
  - 11.13.6.1. Sub-study Amendment: Investigational Product  
and Other Study treatment .....287
  - 11.13.6.2. Sub-study Dosage and Administration .....287
  - 11.13.6.3. Oral Bridging during the Sub-study .....288
- 11.13.7. Sub-study Data Management .....288
- 11.13.8. Sub-study Statistical Considerations and Data Analyses .....288
  - 11.13.8.1. Statistical Hypotheses .....288
  - 11.13.8.2. Sample Size Considerations.....289
  - 11.13.8.3. Data Analysis Considerations .....291
    - 11.13.8.3.1. Analysis Populations.....291
    - 11.13.8.3.2. Planned Analyses .....291
  - 11.13.8.4. Key Elements of Analysis Plan .....291
    - 11.13.8.4.1. Primary Analysis .....291
    - 11.13.8.4.2. Secondary and Exploratory  
Analyses .....292
- 11.13.9. Sub-study Amendment Pharmacokinetics.....292
- 11.14. Appendix 14: Protocol Amendment History .....294



## 1. SYNOPSIS

**Protocol Title:** A Phase IIIb, Randomized, Multicenter, Parallel-group, Non-inferiority, Open-label Study Evaluating the Efficacy, Safety, and Tolerability of Long-acting Cabotegravir Plus Long-acting Rilpivirine Administered Every 8 Weeks or Every 4 Weeks in HIV-1-infected Adults who are Virologically Suppressed.

**Short Title:** Study Evaluating the Efficacy, Safety, and Tolerability of Long-acting Cabotegravir Plus Long-acting Rilpivirine administered every 8 weeks in Virologically Suppressed HIV-1-infected Adults.

### 1.1. Rationale

The 207966 (ATLAS-2M) study is being conducted to establish if human immunodeficiency virus type 1 (HIV-1) infected adult participants with current viral suppression (HIV-1 RNA <50 c/mL) remain suppressed upon administration of a two-drug intramuscular (IM) long-acting (LA) regimen of cabotegravir (CAB) and rilpivirine (RPV) administered every 8 weeks (Q8W; every 2 months). This study is designed to demonstrate the non-inferior antiviral activity of CAB LA 600 mg + RPV LA 900 mg administered every 8 weeks compared with CAB LA 400 mg + RPV LA 600 mg administered every 4 weeks (Q4W; monthly) over a 48-week treatment period. ATLAS-2M will also provide comparative data on antiviral activity, safety, tolerability, and patient satisfaction through Week 152.

Two groups of participants with demonstrated virologic suppression will be enrolled into ATLAS-2M including participants who at Screening are 1) receiving oral standard of care triple antiretroviral therapy (SOC) or 2) receiving a two drug IM regimen of Q4W CAB LA + RPV LA. The majority of participants in ATLAS-2M will rollover from the ongoing 201585 (ATLAS) trial and additional participants on SOC will also be included in order to support a targeted total sample size of approximately 1020 participants. Participants entering on SOC treatment consisting of a stable antiretroviral (ARV) regimen containing 2 nucleoside reverse transcriptase inhibitors (NRTIs) plus an integrase inhibitor (INI), non-nucleoside reverse transcriptase inhibitor (NNRTI), or a protease inhibitor (PI), will therefore either enter as new study participants or will rollover from the ongoing ATLAS trial. All participants entering on Q4W CAB LA + RPV LA will be rolled over from the ATLAS trial.

ATLAS is a Phase III, randomized, multicenter, parallel-group, non-inferiority, open-label study evaluating the efficacy, safety, and tolerability of switching to CAB LA + RPV LA from current INI- NNRTI-, or PI-based antiretroviral regimen in HIV-1-infected adults who are virologically suppressed. ATLAS participants randomized to the SOC, “current antiretroviral” treatment arm, consisting of 2 nucleoside reverse transcriptase inhibitors (NRTIs) plus a third agent (INI, NNRTI, or a PI), or the CAB LA + RPV LA Q4W arm, who successfully complete Week 52 (at minimum) of ATLAS, and remain virologically suppressed (HIV-1 RNA <50 c/mL), will be eligible to enter ATLAS-2M.

Eligible participants entering ATLAS-2M on oral SOC (either from ATLAS or new participants) will be randomized (1:1) to the CAB LA + RPV LA Q4W or Q8W regimen

beginning with 4 weeks of oral lead-in with CAB + RPV to confirm tolerability prior to IM dosing with CAB LA and RPV LA. Eligible participants entering from ATLAS on the CAB LA+ RPV LA Q4W regimen will be randomized (1:1) to either continue Q4W injections or transition to Q8W injections in ATLAS-2M (without the oral lead-in).

All participants who successfully complete Week 100 of CAB LA + RPV LA treatment in the Maintenance Phase will continue to have access to their randomized CAB LA + RPV LA regimen in the Extension Phase through Week 152 and until CAB LA and RPV LA are either locally approved and commercially available, the participant no longer derives clinical benefit, the participant meets a protocol-defined reason for discontinuation or until development of their assigned CAB LA + RPV LA regimen is terminated.

## 1.2. Objectives and Endpoints

Objectives	Endpoints
<b>Primary</b>	
To demonstrate the non-inferior antiviral activity of CAB LA + RPV LA every 8 weeks (every two months) compared to CAB LA + RPV LA every 4 weeks (monthly) over 48 weeks in suppressed HIV-1 infected antiretroviral therapy (ART)-experienced participants	Proportion of participants with plasma HIV-RNA greater than or equal to 50 copies/mL as per Food and Drug Administration (FDA) Snapshot algorithm at Week 48 (Intent-to-Treat Exposed [ITT-E] population)
<b>Secondary</b>	
To demonstrate the antiviral and immunologic activity of CAB LA + RPV LA every 8 weeks compared to CAB LA + RPV LA every 4 weeks	<p>Proportion of participants with plasma HIV-1 RNA &lt;50 c/mL (c/mL) at Week 24, Week 48, Week 96, and Week 152 using the FDA Snapshot algorithm (Intent-to-Treat Exposed [ITT-E] population)</p> <p>Proportion of participants with protocol-defined confirmed virologic failure (CVF) through Week 24, Week 48, Week 96, and Week 152</p> <p>Proportion of participants with HIV-RNA greater than or equal to 50 c/mL as per FDA Snapshot algorithm at Week 24, Week 96, and Week 152</p> <p>Absolute values and changes from Baseline in viral load and CD4+ cell counts over time including Week 48, Week 96, and Week 152</p>

Objectives	Endpoints
<p>To evaluate the safety and tolerability of CAB LA + RPV LA every 8 weeks compared to CAB LA + RPV LA every 4 weeks</p>	<p>Incidence and severity of AEs and laboratory abnormalities over time including Week 24, Week 48, Week 96, and Week 152</p> <p>Proportion of participants who discontinue treatment due to AEs over time including Week 24, Week 48, Week 96, and Week 152</p> <p>Change from Baseline in laboratory parameters over time including Week 48, Week 96, and Week 152</p>
<p>To assess viral resistance in participants experiencing protocol-defined confirmed virologic failure</p>	<p>Incidence of treatment emergent genotypic and phenotypic resistance to CAB, RPV through Week 24, Week 48, Week 96, and Week 152</p>
<p>To characterize CAB and RPV concentrations and population pharmacokinetics and identify important determinants of variability</p>	<p>Plasma PK parameters for CAB LA and RPV LA (when evaluable, <math>C_{\text{trough}}</math>, concentrations post dose [<math>\sim C_{\text{max}}</math>], and area under the curve [AUC])</p> <p>Demographic parameters including, but not limited to, age, sex, race, body weight, body mass index, and relevant laboratory parameters will be evaluated as potential predictors of inter- and intra-participant variability for pharmacokinetic parameters</p>
<p>To assess preference for CAB LA + RPV LA every 8 weeks or CAB LA + RPV LA every 4 weeks LA compared to oral antiretroviral (ARV)</p> <p>To assess preference for CAB LA+ RPV LA every 8 weeks compared to CAB LA + RPV LA every 4 weeks</p>	<p>Preference for CAB LA + RPV LA every 8 weeks and CAB LA + RPV LA every 4 weeks compared to oral ARV and preference for CAB LA + RPV LA every 8 weeks compared to CAB LA + RPV LA every 4 weeks will be assessed using a preference questionnaire at week 48 (or Withdrawal).</p>
<p>To assess patient reported health-related quality of life, treatment satisfaction, injection tolerability, and treatment acceptance.</p>	<p>Change from Baseline (Day 1) in HRQoL at Week 24, and Week 48 (or Withdrawal)</p> <p>Change from baseline (Day 1) in total “treatment satisfaction” score, and individual item scores of the HIV Treatment Satisfaction Status Questionnaire (HIVTSQs) at Week 24, 48, and 152 (or Withdrawal)</p>

Objectives	Endpoints
	<p>Change in treatment satisfaction over time using the HIV Treatment Satisfaction Change Questionnaire HIVTSQc at Week 48 (or Withdrawal).</p> <p>Change from Week 8 in Dimension scores (“Bother of ISRs”, “Leg movement”, “Sleep”, and “Injection Acceptance”) and individual item scores assessing pain during injection, anxiety before and after injection, willingness to be injected in the future and overall satisfaction with mode of administration over time will be assessed using the Perception of iNjection questionnaire (PIN) at Weeks 8, 24, 48, and 152 (or Withdrawal)</p> <p>Change from Baseline (Day 1) in treatment acceptance at Week 24, Week 48 and Week 152 (or Withdrawal) will be assessed using the “General acceptance” dimension of the Chronic Treatment Acceptance (ACCEPT) questionnaire</p>

**1.3. Overall Design**

Study 207966 (Antiretroviral Therapy as Long Acting Suppression every 2 Months- ATLAS-2M) is a Phase III, randomized, open-label, active-controlled, multicenter, parallel-group, non-inferiority study designed to assess the antiviral activity and safety of CAB LA + RPV LA administered every 4 weeks compared to CAB LA + RPV LA administered every 8 weeks in approximately 1020 adult HIV-1 infected participants.

Two groups of patients who fulfill eligibility requirements will be randomized (1:1) to receive CAB LA + RPV LA Q4W, or CAB LA + RPV LA Q8W regimen for at least 100 weeks:

Group 1: Patients randomized from current ART SOC therapy

Patients randomized from current ART SOC therapy, including those enrolled to the “current ART” arm of the ATLAS study following completion of the Week 52 visit (at minimum), will begin oral therapy with CAB 30 mg + RPV 25 mg once daily at Day 1 for 28 days (±3 days) to determine individual safety and tolerability prior to receiving CAB LA + RPV LA Q4W, or CAB LA + RPV LA Q8W. For patients on SOC transitioning from the ATLAS trial, eligibility for ATLAS-2M can be determined once

the final central lab results from ATLAS are available and safety parameters have been reviewed.

Group 2: Patients currently receiving CAB LA + RPV LA Q4W

Patients currently receiving CAB LA + RPV LA Q4W within ATLAS will be randomized at Day 1 to either continue Q4W administration or transition to Q8W administration of CAB LA + RPV LA. Eligible patients include those originally randomized to Q4W in the Maintenance phase of ATLAS and those who transitioned from SOC to the Q4W regimen within the Extension Phase of ATLAS. The first injection visit for ATLAS-2M can be performed once the final central lab results from ATLAS are available and safety parameters have been reviewed, and the ATLAS Week 52 visit (at minimum) has been completed. Participants will continue to receive CAB LA + RPV LA Q4W injections as scheduled within the ATLAS trial until their eligibility for ATLAS-2M can be fully evaluated and the participant is re-randomized (Q4W or Q8W). If determined to be ineligible for ATLAS-2M, those participants can elect to continue participation in ATLAS or withdraw from the ATLAS study.

Participants in ATLAS-2M who successfully complete Week 100 (without meeting study defined withdrawal criteria) will be given the option to continue to receive their randomized treatment (CAB LA + RPV LA administered Q4W or Q8W) in the Extension Phase through Week 152 and until the study treatment is either locally approved and commercially available within the local sector (including through local public/government health sectors), the participant no longer derives clinical benefit, the participant meets a protocol-defined reason for discontinuation or until development of either CAB LA + RPV LA Q4W and/or Q8W is terminated. Alternatively, participants can choose to complete study participation and enter the 52-week Long-Term Follow-Up (LTFU) Phase of the study.

Any participant who receives at least one dose of CAB LA and/or RPV LA and discontinues the CAB LA + RPV LA regimen for any reason will enter a 52-week LTFU Phase (please refer to Section 1.4.4 of the synopsis for additional details). Those participants must remain on suppressive highly active antiretroviral therapy (HAART) for at least 52 weeks after the last dose of CAB LA and/or RPV LA.

In order to achieve balance across the treatment arms, randomization will be stratified by prior CAB + RPV Exposure: 0 weeks, 1-24 weeks, >24 weeks. The primary endpoint for the study is the proportion of participants with HIV-RNA greater than or equal to 50 c/mL (Virologic Failure) at Week 48 as per Food and Drug Administration (FDA) Snapshot algorithm using the Intent-to-Treat Exposed (ITT-E) population. The proportion of participants with plasma HIV-1 RNA <50 c/mL at Week 48 using the FDA Snapshot algorithm (Missing, Switch or Discontinuation = Failure, ITT-E population) is a key secondary endpoint comparison.

The sample size of 1020 provides 85% power to demonstrate non-inferiority in the primary endpoint at Week 48 using a 4% margin, assuming a true 3% failure rate for Q8W CAB LA + RPV LA and a 2% failure rate for the Q4W CAB LA + RPV LA arm and a 2.5% one-sided alpha level (using unpooled Z test statistic).

**1.3.1. 207966 (ATLAS-2M) Study Design Schematic**

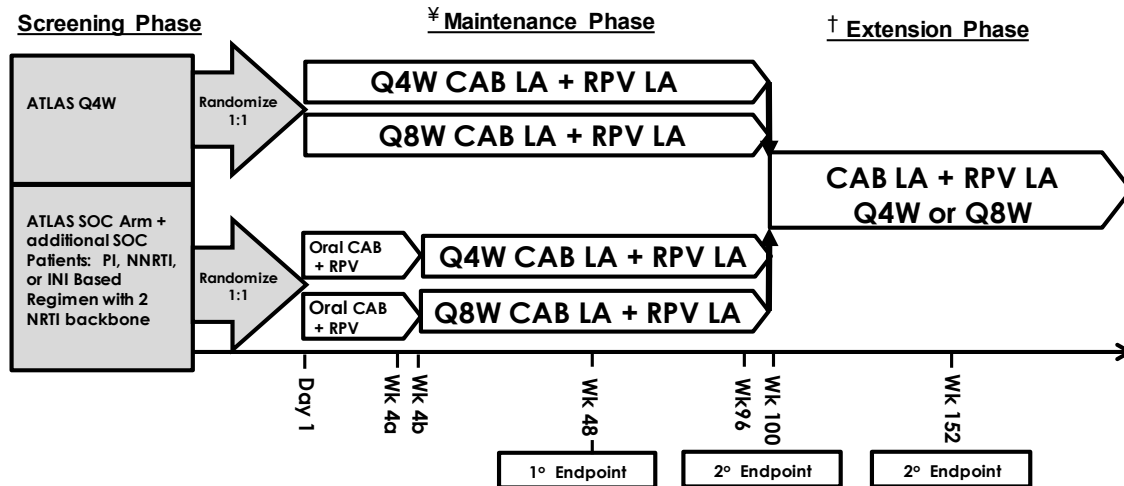

N=1020, randomized 1:1 to each arm and stratified by prior CAB + RPV Exposure  
 # SOC Patients not transitioning from the ATLAS study must be on uninterrupted current regimen (either the initial or second cART regimen) for at least 6 months prior to Screening. Documented evidence of at least two plasma HIV-1 RNA measurements <50 c/mL in the 12 months prior to Screening: one within the 6 to 12 month window, and one within 6 months prior to Screening. No history of virologic failure. No evidence of viral resistance based on the presence of any resistance-associated major INI, or NNRTI mutation (except K103N) from prior genotype assay results. No current or prior history of etravirine use.  
 †Optional Extension Phase to continue randomized CAB LA + RPV LA Q4W or Q8W at Wk 100  
 ‡Participants who withdraw from IM regimen must go into 52 week long term follow up phase if randomized regimen is not yet locally approved and commercially available.

**1.3.2. Number of Participants**

The target population to be enrolled is HIV-1 infected virologically suppressed (HIV-1 RNA <50 c/mL) patients on stable antiretroviral therapy (ART) including participants who have completed, at minimum, Week 52 of the ATLAS study.

It is anticipated that approximately 1020 participants will be enrolled into ATLAS-2M. In addition to participants rolled over from the ATLAS study, additional participants on SOC treatment will be screened to supplement enrollment such that the study can be appropriately powered. A 15% screen failure rate, for additional patients randomized from SOC treatment is anticipated. Participants will be enrolled from multiple countries which may include those countries actively participating in the ATLAS study including Australia, Argentina, Canada, France, Germany, Italy, Mexico, Russia, South Africa, South Korea, Spain, Sweden, and the United States.

Randomization will be stratified by prior CAB + RPV exposure: 0 weeks, 1-24 weeks, >24 weeks. A goal of this study is to enroll populations who are underrepresented in

clinical studies including approximately 25% women. To provide sufficient data to determine whether either gender is correlated with treatment response, sites are expected to take into account gender in their screening strategies.

#### 1.4. Treatment Groups and Duration

##### 1.4.1. Screening Phase (Up to 35 days)

Informed consent must be obtained prior to any study procedures, including any Screening assessment.

Participants will be involved in a Screening period of up to 35 days and may be re-screened once. Participants who are randomized into the trial and subsequently withdrawn from the study, for any reason, may not be re-screened. Participants may be randomized as soon as all eligibility requirements have been confirmed at the site.

For participants transitioning from the ATLAS study, eligibility to transition to ATLAS-2M at Week 52 (at the earliest) will be determined once the final central lab results from ATLAS, following (at minimum) completion of the ATLAS Week 48 visit are available and safety parameters have been reviewed. Separate Screening Labs will be utilized to inform eligibility for ATLAS-2M; however, in some occasions and upon consultation with the Medical Monitor, individual lab results and safety data from the final visit of the ATLAS study can be considered towards informing eligibility for the ATLAS-2M study as long as all other Screening and eligibility criteria are met.

##### 1.4.2. Maintenance Phase (Day 1 up to Week 100)

There are two ways in which study participants may transition to the LA regimen, either directly from oral SOC or from Q4W dosing from ATLAS.

The Table and Figure below describe the CAB LA + RPV LA dosing regimens in ATLAS-2M based on the mode of transition.

#### CAB LA + RPV LA Dosing Regimens in ATLAS-2M

<b>Participants Transitioning from Oral Standard of Care (SOC)</b>		
<b>Regimen</b>	<b><u>CAB LA</u></b>	<b><u>RPV LA</u></b>
Q4W	<u>CAB LA:</u> Week 4b: 600 mg (Loading Dose) Week 8 & Q4W thereafter: 400 mg	<u>RPV LA:</u> Week 4b: 900 mg (Loading Dose) Week 8 & Q4W thereafter: 600 mg
Q8W	<u>CAB LA:</u> Week 4b, Week 8, & Q8W thereafter: 600 mg	<u>RPV LA:</u> Week 4b, Week 8, & Q8W thereafter: 900 mg

<b>Participants Transitioning from ATLAS Q4W</b>		
<b>Regimen</b>	<b>CAB LA</b>	<b>RPV LA</b>
Q4W	<u>CAB LA:</u> Day 1 & Q4W thereafter: 400 mg	<u>RPV LA:</u> Day 1 & Q4W thereafter: 600 mg
Q8W	<u>CAB LA:</u> Day 1 & Q8W thereafter: 600 mg	<u>RPV LA:</u> Day 1 & Q8W thereafter: 900 mg

All participants entering ATLAS-2M from an oral SOC regimen will receive a 4-week oral lead-in of CAB+RPV prior to receiving IM injections, except for ATLAS subjects transitioning from Q4W to Q8W injections. These participants previously established safety and tolerability of CAB + RPV within the ATLAS study.

**ATLAS-2M Treatment Schematic**

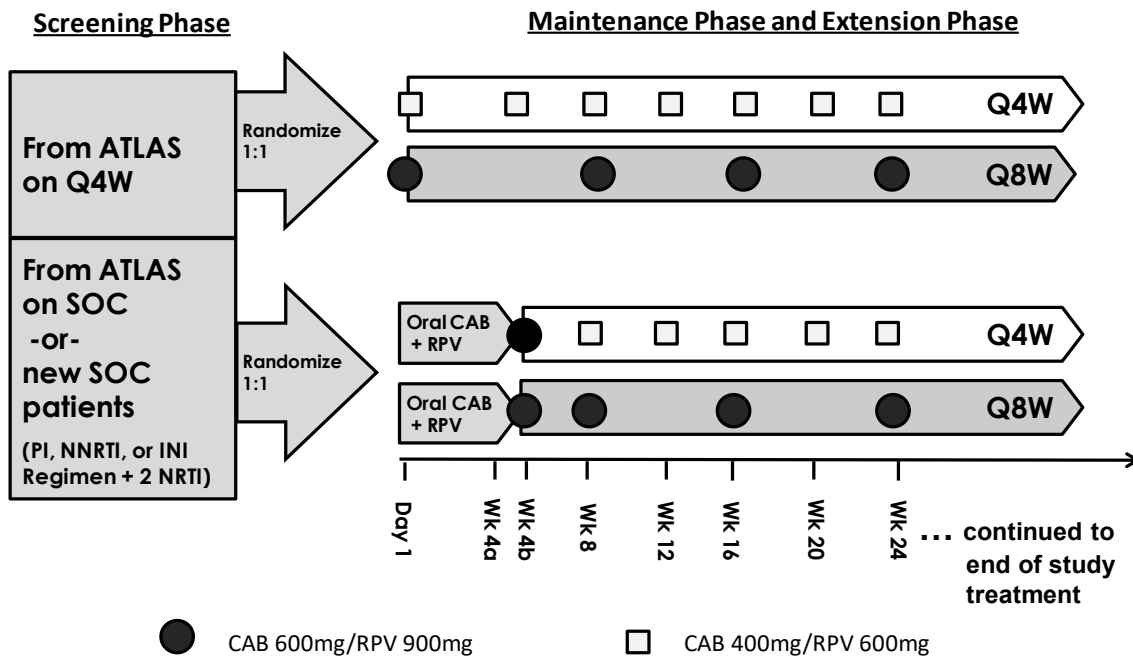

**1.4.2.1. Patients randomized to LA dosing from current ART SOC therapy:**

All participants randomized from current ART SOC therapy (including those transitioning from SOC in ATLAS and new study participants) will begin oral therapy with CAB 30 mg + RPV 25 mg once daily at Day 1 for 4 weeks to determine individual safety and tolerability prior to administration of CAB LA + RPV LA. The oral lead-in period is part of the Maintenance Phase and will therefore be included within the Week 48, 96, and 152 planned analyses.

The final dosing of current daily oral ART regimen should occur the day prior to randomization to avoid overlap of treatment regimens however, if the participant takes



current ART prior to coming into the clinic, randomization and initiation of oral CAB and RPV should continue as planned for Day 1. At the Week 4a visit, safety assessments (including e.g., clinical chemistries) will be performed as per the Time and Events Table to determine individual safety and tolerability prior to the initial administration of CAB LA + RPV LA. Dosing of CAB LA + RPV LA Q4W or Q8W will initiate at the Week 4b visit once safety labs from Week 4a are available and have been reviewed.

Subjects receiving oral SOC treatment and randomized to Q4W injections will receive loading doses of CAB LA 600 mg + RPV LA 900 mg on **Week 4b** followed by maintenance injections of CAB LA 400 mg + RPV LA 600 mg every 4 weeks thereafter.

Subjects receiving oral SOC treatment and randomized to Q8W injections will receive doses of CAB LA 600 mg + RPV LA 900 mg on **Week 4b and Week 8** followed by identical maintenance dose injections every 8 weeks thereafter.

All injections should be planned as single injections per drug.

**1.4.2.1.1. IM injections every 4 weeks (Q4W from SOC):**

Week 4b visit only - CAB LA 600 mg + RPV LA 900 mg, each given as 1 X 3 mL IM injection

Week 8 visit and Q4W thereafter - CAB LA 400 mg IM + RPV LA 600 mg IM every 4 weeks for 100 weeks, each given as 1 X 2 mL IM injection

At Week 4b, participants will return to the clinic, take the last oral dose (CAB 30 mg + RPV 25 mg), and receive the first CAB LA (600 mg) + RPV LA (900 mg) injections (within 2 hours of the final oral dose of CAB + RPV). The first injection visit with IM CAB LA + RPV LA at Week 4b can be performed once central lab results are available and safety parameters are reviewed from the Week 4a visit.

The second and third IM injections with CAB LA 400 mg and RPV LA 600 mg will be performed at Week 8 and Week 12. There will be a -7-day dosing window for the second and third IM injections such that the second injection occurs within the window of Week 7 and Week 8 but no later than Week 8 and the third injection occurs within the window of Week 11 and Week 12 but no later than Week 12. Subsequent injections with CAB LA 400 mg and RPV LA 600 mg will occur every 4 weeks ( $\pm 7$  days) thereafter. In addition, starting after the Week 16 injection, the interval between injection visits will be limited to a maximum of 5 weeks. The Medical Monitor must be contacted to discuss individual participant case management if the length of time between injections exceeds or is projected to exceed 5 weeks.

**1.4.2.1.2. IM injections every 8 weeks (Q8W from SOC):**

Week 4b visit – CAB LA 600 mg + RPV LA 900 mg IM, each given as 1 X 3 mL IM injection

Week 8 visit- CAB LA 600 mg + RPV LA 900 mg IM, each given as 1 X 3 mL IM injection

Week 16 visit and Q8W thereafter - CAB LA 600 mg + RPV LA 900 mg IM, every 8 weeks for 100 weeks, each given as 1 X 3 mL IM injection

At the Week 4b visit, subjects will return to the clinic, take their last oral dose (CAB 30 mg + RPV 25 mg), and receive the first CAB LA (600 mg) + RPV LA (900 mg) injections (within 2 hours of the final oral dose of CAB + RPV). The first injection visit with IM CAB LA + RPV LA at Week 4b can be performed once central lab results are available and safety parameters are reviewed from the Week 4a visit.

The second loading injection will be administered at Week 8 (CAB LA 600 mg + RPV LA 900 mg), with subsequent injections (CAB LA 600 mg + RPV LA 900 mg) occurring every 8 weeks thereafter. There will be a -7-day dosing window for the second and third IM injections such that the second injection occurs within the window of Week 7 and Week 8 but no later than Week 8 and third injection occurs within the window of Week 15 and Week 16 but no later than Week 16. Subsequent injections with CAB LA 600 mg and RPV LA 900 mg will occur every 8 weeks ( $\pm 7$  days). Starting after the Week 16 injection, the interval between injection visits will be limited to a maximum of 9 weeks. If the length of time between injections exceeds, or is projected to exceed 9 weeks, the Medical Monitor must be contacted to discuss individual participant case management.

#### **1.4.2.2. Participants transitioning from ATLAS and currently receiving CAB LA + RPV LA Q4W**

Subjects receiving Q4W injections within ATLAS and randomized to receive Q4W injections in ATLAS-2M, will continue receiving maintenance injections Q4W as scheduled and will not require a loading dose on Day 1.

Subjects receiving Q4W injections within ATLAS and randomized to receive Q8W injections in ATLAS-2M will receive doses of CAB LA 600 mg + RPV LA 900 mg on Day 1 one month after their last Q4W maintenance dose in order to align with day of study randomization. Subjects will not require an intermediate dose at Week 4 and will receive their next Q8W maintenance injections at Week 8 and Q8W thereafter.

Participants transitioning from the ATLAS study and on CAB LA + RPV LA Q4W treatment will be randomized at Day 1 to either continue Q4W administration or transition to Q8W administration of CAB LA + RPV LA. The first injection visit for the ATLAS-2M study can be performed once the final central lab results from the ATLAS study are available and safety parameters have been reviewed. Screening labs determining eligibility for ATLAS-2M can be collected at Week 48 (at minimum) for participants originally randomized to the Q4W arm within ATLAS. Screening labs for participants who recently transitioned from SOC to Q4W injections within the ATLAS Extension Phase may be obtained at ATLAS Week 56b (after completion of the CAB + RPV Oral lead-in period) or at a subsequent ATLAS visit after receiving one set or a short course of Q4W injections. The transition from the final ATLAS to ATLAS-2M Day 1 dosing must occur 4 weeks ( $\pm 7$  days) from the final injections received in ATLAS.

Dosing for participants transitioning from CAB LA + RPV LA Q4W in ATLAS is as follows:

**1.4.2.2.1. IM injections every 4 weeks (Q4W from ATLAS Q4W):**

Starting at Day 1, all injections will continue with the maintenance dose of CAB LA 400 mg and RPV LA 600 mg administered every 4 weeks ( $\pm 7$  days). In addition, the time between injection visits will be limited to a maximum of 5 weeks. The Medical Monitor must be contacted if the length of time between injections exceeds or is projected to exceed 5 weeks.

**1.4.2.2.2. IM injections every 8 weeks (Q8W from ATLAS Q4W):**

Participants transitioning from ATLAS and randomized to receive CAB LA + RPV LA Q8W injections will initiate Q8W dosing at the Day 1 visit as follows:

Day 1- CAB LA 600 mg + RPV LA 900 mg IM, each given as 1 X 3 mL IM injection

Week 8 and Q8W thereafter- CAB LA 600 mg + RPV LA 900 mg IM, each given as 1 X 3 mL IM injection

The second injection will be administered at Week 8 (CAB LA 600 mg + RPV LA 900 mg, with subsequent injections (CAB LA 600 mg + RPV LA 900 mg) occurring every 8 weeks thereafter. There will be a -7-day dosing window for the second and third IM injections such that the second injection occurs within the window of Week 7 and Week 8 but no later than Week 8 and third injection occurs within the window of Week 15 and Week 16 but no later than Week 16. Subsequent injections with CAB LA 600 mg and RPV LA 900 mg will occur every 8 weeks ( $\pm 7$  days). Starting after the Week 16 injection, the interval between injection visits will be limited to a maximum of 9 weeks. If the length of time between injections exceeds, or is projected to exceed 9 weeks, the Medical Monitor must be contacted to discuss individual participant case management.

The primary study analysis will consist of data collected through the Week 48 visit. A single repeat of HIV-1 RNA for any participant with a HIV-1 RNA  $\geq 50$  c/mL at Week 48, Week 96, or Week 152 must be performed. The retest should be scheduled as soon as possible (but no later than 4 weeks from the Week 48, Week 96, or Week 152 visits, respectively) and will inform the Week 48, Week 96, or Week 152 virological endpoint, respectively.

**1.4.3. Extension Phase**

Participants who successfully complete 96 Weeks of CAB LA + RPV LA treatment in the Maintenance Phase will continue to have access to their randomized treatment Q4W or Q8W CAB LA + RPV LA in the Extension Phase through Week 152 and until study treatment is either locally approved and commercially available within the local sector (including through local public/government health sectors), the participant no longer derives clinical benefit, the participant meets a protocol-defined reason for discontinuation or until development of either CAB LA + RPV LA Q4W and/or Q8W is terminated. For participants randomized to Q4W arm, dosing visits will continue to occur every 4 weeks with CAB LA 400mg and RPV LA 600 mg. For participants randomized to the Q8W arm, dosing visits will continue to occur every 8 weeks with

CAB LA 600 mg and RPV LA 900 mg. Safety and efficacy assessments will be conducted as per the Time and Events Schedule.

Participants choosing to not enter the Extension phase can complete their study participation at the Week 100 visit and enter into the LTFU Phase as required.

Participants who choose to continue on to the Extension Phase will need to be assessed for eligibility and will continue on their current CAB LA + RPV LA regimen while eligibility is being confirmed. A single repeat of HIV-1 RNA for any participant with a HIV-1 RNA  $\geq 50$  c/mL and  $< 400$  c/mL at Week 96 or Week 152 must be performed. The retest should be scheduled as soon as possible (but no later than 4 weeks from the Week 96 or Week 152 visit). Participants with HIV-1 RNA  $< 50$  c/mL upon retest are eligible to enter the Extension Phase. Participants with HIV-1 RNA  $\geq 400$  c/mL at Week 96 are not eligible to enter the Extension Phase, will not be allowed a repeat to determine eligibility, and will therefore be withdrawn from the study treatment. Eligibility to enter the Extension Phase for any participants with a retest HIV-1 RNA  $> 50$  c/mL and  $< 400$  c/mL will require approval by the study Medical Monitor.

Participants not eligible to enter the Extension Phase or choosing not to participate in the Extension Phase will end their study treatment and enter the LTFU Phase. Sites may be reimbursed for up to a one-month supply of antiretroviral medication to facilitate transition to non-study ART for participants that do not qualify for the Extension Phase.

#### 1.4.4. Long-Term Follow-Up Phase

- Any participant who receives at least one dose of CAB LA and/or RPV LA and discontinues the CAB LA + RPV LA regimen for any reason before CAB LA + RPV LA marketed product is locally available must enter the LTFU Phase. Participants must remain on suppressive HAART for at least 52 weeks after the last dose of CAB LA and/or RPV LA in order to prevent selective pressure on HIV and the potential for selection of resistant mutants. **Investigators must discuss the choice of the follow-up HAART regimen with the Medical Monitor prior to initiating the new regimen with the participant. HAART therapy should be initiated within 4 weeks (+7 days) after the last Q4W injection, or within 8 weeks (+7 days) after the last Q8W injection.** The LTFU Phase will begin the day of the last CAB LA and/or RPV LA dose and continue for 52 weeks.. Upon discontinuation from the Maintenance or Extension Phase, these participants will complete Withdrawal assessments (see Section 5.5) and will then enter into the LTFU Phase as per the Time and Events Schedule (Section 7.1).
- Where the CAB LA + RPV LA marketed product is locally available, only participants that discontinue the CAB LA + RPV LA regimen for **safety-related reasons** included in Section 5.5, must enter the LTFU Phase. Participants must remain on suppressive HAART for at least 52 weeks after the last dose of CAB LA and/or RPV LA in order to prevent selective pressure on HIV and the potential for selection of resistant mutants. **Investigators must discuss the choice of the follow-up HAART regimen with the Medical Monitor prior to**

**initiating the new regimen with the participant. HAART therapy should be initiated within 4 weeks ( $\pm$  7 days) after the last Q4W injection, or within 8 weeks ( $\pm$  7 days) after the last Q8W injection.** The LTFU Phase will begin the day of the last CAB LA and/or RPV LA dose and continue for 52 weeks. These participants will complete Withdrawal assessments prior to entering into the LTFU Phase as per the Time and Events Schedule. In addition, for participants who withdraw during the LTFU, the final visit will be considered the study withdrawal visit.

- NOTE: Participants transitioning to CAB+RPV LA marketed product or alternative HAART (except due to safety-related reasons) do not need to enter the LTFU Phase.

### Long term Follow up phase requirement

Marketed product locally available	Subject WD due to safety-related reasons	LTFU phase required?
No	Yes	Yes
	No	
Yes	Yes	Yes
	No	No, but Safety FU visit required to assess potential safety issues occurred after the last injection

Participants will be assessed with clinic visits at months 3, 6, 9, and 12 during the Follow-Up Phase. Female participants of child bearing potential must continue to use adequate contraception methods (see Study Procedures Manual for list of accepted forms of contraception) for the entire year of follow up.

In order to assure that participants have access to HAART during the LTFU Phase, GSK may supply HAART regionally or reimbursement will be provided as needed during this phase. The LTFU Phase may be modified or terminated at any time during the study for various reasons, e.g., better understanding of risks of development of resistance as CAB and RPV exposures decline, regulatory approval and commercial availability, end of study timings, etc.

This phase is considered study participation and participants will be followed on study during this time. Additional withdrawal assessments are not required for participants who do not complete the LTFU Phase.

#### **1.4.5. Dose Modifications:**

No dose reductions, modifications, or changes in the frequency of any components of each regimen will be allowed during the study beyond what is allowed within the protocol or directly approved by the study Medical Monitor. Protocol waivers or exemptions are not allowed. Therefore, adherence to the study design requirements is essential and required for study conduct.

In exceptional circumstances, and in consultation with the Medical Monitor, Investigators may provide oral CAB and/or RPV as a short-term “bridging” strategy for participants who have begun CAB LA + RPV LA. Should a participant need “oral bridging”, sites must contact the Medical Monitor for guidance on treatment strategies prior to a missed CAB LA + RPV LA dose. Should a participant not notify the site in advance, the Medical Monitor must be contacted for further treatment guidance.

Supplementary study conduct information not mandated to be present in this protocol is provided in the accompanying Study Procedures Manual (SPM), which is available on the online Study Web Portal. The SPM will provide the site personnel with administrative and detailed technical information.

## **2. INTRODUCTION**

Current HIV treatment guidelines recommend first-line antiretroviral (ARV) regimens consisting of two nucleoside/nucleotide analogue reverse transcriptase inhibitors (NRTIs) as a “backbone” combined with a third agent from the non-nucleoside reverse transcriptase inhibitor (NNRTI), protease inhibitor (ritonavir-boosted) (PI/RTV), or integrase strand transfer inhibitor (INSTI) classes [BHIVA, 2016; DHHS, 2016; EACS, 2017; IAS USA, 2016]. While these regimens are highly efficacious and generally well tolerated, there is growing concern about long-term toxicities, and great interest from patients and clinicians in unique regimens that might avoid such toxicities, and to provide effective long-term antiretroviral therapy ART with the most streamlined and convenient regimens possible.

The current paradigm in the treatment of Human Immunodeficiency Virus (HIV) involves life-long therapy with multiple antiretrovirals. This dependency on medical therapy requires additional improvements on the durability, safety and tolerability, and convenience of all antiretroviral classes. Fixed-dose combinations (FDCs) have greatly advanced HIV treatment by allowing simplification of dosing and reducing pill burden. However, adherence to therapy is essential to achieve viral suppression and prevent emergence of resistance mutations. Among regimens of comparable efficacy, physicians and HIV-1-infected patients who receive ART rate total pill burden, dosing frequency, and safety concerns among the greatest obstacles to achieving adherence. Drug resistant virus eventually emerges in most patients who struggle with consistent adherence. Different HIV treatment modalities are being developed to help improve adherence and patient outcomes, and prevent resistance and transmission of the virus.

There is also an increasing desire to develop nucleoside reverse transcriptase inhibitor (NRTI)-sparing regimens for long-term treatment of HIV infection as an approach to

avoid known NRTI-associated adverse drug reactions and long-term toxicities. In addition, while there are no currently approved two-drug regimens to maintain suppression, simplifying treatment has long been a goal to increase treatment compliance and improve the quality of life for patients with HIV.

Cabotegravir (CAB) is a potent integrase inhibitor that possesses attributes that allow formulation and delivery as a long-acting (LA) parenteral product. Rilpivirine (RPV) is a diarylpyrimidine derivative and a potent non-nucleoside reverse transcriptase inhibitor (NNRTI) with *in vitro* activity against wild type HIV-1 and select NNRTI-resistant mutants. RPV is a globally marketed product available as oral 25 mg tablets, and is also formulated as a LA product. Intramuscular administration of a two-drug combination therapy with CAB LA plus RPV LA may offer a better tolerability and resistance profile, as well as improved adherence and treatment satisfaction in virologically suppressed patients.

## 2.1. Study Rationale

The overall objective of the CAB LA + RPV LA clinical development program is to develop a highly effective, well tolerated two drug long-acting injectable regimen which has the potential to offer improved treatment convenience, compliance and improved quality of life for individuals with HIV compared to current standard of care. Week 96 efficacy data from study 200056 (LATTE-2) demonstrated that 94% of patients on the CAB LA + RPV LA Q8W dosing arm and 87% of patients on the Q4W dosing arm maintained virologic suppression (HIV-1 RNA <50 c/mL), with both regimens being well tolerated. LATTE-2 results justify further evaluation of CAB LA + RPV LA dosing regimens. Study 201585 (ATLAS) is an ongoing Phase III study conducted to establish if human immunodeficiency virus type 1 (HIV-1) infected adult participants with current viral suppression on a regimen with 2 nucleoside reverse transcriptase inhibitors (NRTIs) plus a third agent, remain suppressed upon switching to CAB LA + RPV LA Q4W. The current study, 207966 (ATLAS-2M) is designed to demonstrate the non-inferior antiviral activity of CAB LA 600 mg + RPV LA 900 mg every 8 weeks (Q8W, every 2 months) compared to CAB LA 400 mg + RPV LA 600 mg administered every 4 weeks (Q4W, monthly) for 48 weeks. This study will also provide important long-term comparative antiviral activity, safety, tolerability of these regimens through Week 152 of the Extension Phase of the study. Additionally, eligible participants (HIV-1 RNA <50 c/mL at Week 96) will be given an option to continue their randomized CAB LA + RPV LA regimen (Q4W or Q8W) in the Extension Phase of the study.

## 2.2. Background

It is estimated that 36.7 million people are currently living with HIV/Acquired Immunodeficiency Syndrome (AIDS) and that the worldwide epidemic continues to grow at a rate of two million new infections and cause 1.1 million deaths per year [UNAIDS, 2016]. Chronic HIV infection in adults continues to be characterized by increased development of resistant virus, increasing transmission of resistant virus and issues associated with long term toxicity of ART. The current paradigm in the treatment of HIV involves life-long therapy with multiple antiretrovirals. This dependency on medical

therapy requires a need for continuous improvement on the durability, tolerability and convenience of all antiretroviral classes.

A study by the Antiretroviral Therapy Cohort Collaboration [[ART-CC, 2013](#)] found that of more than 21,000 patients in a European and North American cohort on their first combination antiretroviral therapy (cART) regimen (either PI or NNRTI-based), 51% modified or interrupted their first cART regimen during a median of 28 months of follow-up with one third of interruptions occurring within the first 6 months of starting therapy. Forty percent of all treatment interruptions were due to the secondary side effects or toxicities of cART, 17% were due to the desire for simplification of the regimen and 14% were due to patient choice. These observations have led to numerous “switch” ART studies, designed to understand the efficacy, safety, and tolerability of switching patients from one regimen to another.

Previous studies have evaluated switches to ritonavir-boosted PI monotherapy in virologically suppressed patients [[Bierman, 2009](#) and [Arribas, 2012](#)]. These studies suggest that simplifying from a three drug dual class regimen to a single boosted protease inhibitor may be a safe and effective option for the majority of participants studied, who have effectively maintained viral suppression. In the OLE study, virologically suppressed (HIV-1 RNA <50 c/mL) HIV-1 infected participants receiving a lopinavir-ritonavir (LPV/r) + lamivudine (3TC) or emtricitabine (FTC) based NRTI regimen simplified to a dual regimen of LPV/r + 3TC or FTC. In a modified Intent-to-Treat (m-ITT) analysis, dual therapy with LPV/r + 3TC demonstrated non-inferiority efficacy and comparable safety to LPV/r + 2 NRTIs [[Arribas, 2015](#)].

The 200056 study (GlaxoSmithKline Document Number [2013N168152\\_05](#), Study [LATTE-2]) is an ongoing Phase 2b study designed to assess the induction of virologic suppression with CAB 30 mg daily + two NRTIs, followed by a maintenance period where subjects are randomized (1:2:2) to continue on oral CAB 30 mg + two NRTIs or switch to an IM injection of CAB LA + RPV LA administered Q4W or Q8W. A total of 309 participants were enrolled and treated.

During the Induction Phase there was a rapid and sustained decline in HIV-1 RNA, with 91% of participants (282/309) achieving HIV-1 RNA <50 c/mL through 20 weeks of therapy. There was a single participant (with known compliance issues) with confirmed virologic failure during the Induction period. Virologic testing revealed no treatment emergent phenotypic or genotypic resistance in this participant.

The primary endpoint for 200056 was the Week 32 proportion of participants with HIV-1 RNA <50 c/mL (Snapshot, Intent-to-Treat Maintenance Exposed population [ITT-ME]). Following virologic suppression on three drug oral therapy in the Induction Phase, 286 participants qualified to enter randomization at the Day 1 visit, and were subsequently randomized 2:2:1 onto once every 4 weeks intramuscular (IM) injections with CAB LA + RPV LA every 4 weeks (Q4W), once every 8 weeks (Q8W) IM injections with CAB LA + RPV LA or continuation of oral CAB + NRTIs, respectively. Through 32 weeks of two-drug maintenance therapy, 95% (Q8W) and 94% (Q4W) of participants on injectable dosing were virologic successes, compared to 91% of participants continuing three drug



oral CAB + NRTIs, meeting pre-specified criteria for comparability between the dosing arms.

Week 48 was a secondary endpoint for 200056, and permitted the evaluation of the two-drug long-acting combinations' ability to maintain the virologic suppression demonstrated at Week 32. At Week 48, 92% (Q8W) and 91% (Q4W) of participants receiving injectable dosing had a sustained virologic response (HIV-1 RNA <50 c/mL) compared to 89% of participants continuing oral CAB + 2 NRTIs. Week 96 efficacy data from study 200056 (LATTE-2) demonstrated that 94% of patients on the CAB LA + RPV LA Q8W dosing arm and 87% of patients on the Q4W dosing arm maintained virologic suppression (HIV-1 RNA <50 c/mL), with both regimens being well tolerated.

At Week 48, 10 subjects met virologic nonresponse criteria (Q8W, n=8; Q4W, n=1; oral CAB +2 NRTIs, n=1). For the Q8W IM arm, 4 subjects with virologic nonresponse at Week 48 (HIV-1 RNA >50 c/mL) were re-suppressed with HIV-1 RNA <50 c/mL at Week 96 without a change in therapy. Of 5 Q8W subjects with virologic nonresponse at Week 96, two had HIV-1 RNA ≥50 c/mL at Week 96 (one of which had HIV-1 ≥50 c/mL at Week 48), one discontinued due to protocol-defined virologic failure at Week 4, one withdrew consent due to intolerability of injections at Week 8, and one withdrew due to investigator discretion at Week 48 while not suppressed (and subsequently confirmed as a protocol-defined virologic failure). One of the two subjects with HIV-1 RNA >50 c/mL at Week 96 remained on the study and had HIV-1 levels <50 c/mL at the next scheduled visit. Through 96 weeks, no subjects in the Q4W arm failed for virologic reasons. The Q4W subject with virologic nonresponse at Week 48 (HIV-1 RNA, 59 c/mL) remained on the study beyond Week 48 and had subsequent viral re-suppression with HIV-1 <50 c/mL at Week 96. CAB LA + RPV LA was well tolerated through Week 96 for both the Q8W and Q4W dosing regimens, as demonstrated by a low discontinuation rate due to AEs, including injection site reaction (ISR) related AEs in either dosing arm, with no significant dose-dependent trends in safety parameters. Through Week 96, the proportion of AEs leading to withdrawal during the study Maintenance Period was low across all arms (Q8W IM: n=2, 2%; Q4W IM: n=8, 7%; Oral CAB; n=1, 2%), with only one additional AE leading to withdrawal since the Week 48 analysis.

Long-acting two class therapy consisting of CAB LA + RPV LA as an IM regimen has the benefit of being a NRTI-sparing regimen for long-term treatment of HIV infection which will avoid known NRTI-associated adverse drug reactions and long-term toxicities. Additionally, a two-drug combination therapy with CAB LA plus RPV LA may offer a better tolerability and resistance profile, as well as improved adherence and treatment satisfaction in virologically suppressed participants improving the quality of life for patients with living with HIV.

The primary objective of ATLAS-2M is to demonstrate the non-inferior antiviral activity of CAB LA 600 mg + RPV LA 900 mg every 8 weeks (Q8W, every 2 months) compared to CAB LA 400 mg + RPV LA 600 mg administered every 4 weeks (Q4W, monthly) for 48 weeks. ATLAS-2M will also evaluate long-term antiviral and immunologic effects, safety and tolerability, and viral resistance of the Q8W and Q4W regimens for a minimum of 100 weeks. In addition, ATLAS-2M will assess patient reported health-

related quality of life, treatment satisfaction, injection tolerability, and treatment acceptance of the Q8W and Q4W regimens.

### **2.3. Benefit/Risk Assessment**

Summaries of findings from both clinical and non-clinical studies conducted with oral and LA CAB and LA RPV can be found in the current Investigator's Brochures.

The following section outlines the risk assessment and mitigation strategy for this protocol:

#### **2.3.1. Risk Assessment**

##### **Oral CAB and CAB LA (GSK1265744/GSK1265744 LA)**

Since CAB exposure in humans with or without HIV infection is limited, the clinical safety profile in humans has yet to be fully elucidated. The following risks have primarily been identified during routine preclinical testing and/or from the clinical trial experience to date and are considered of potential relevance to clinical usage in the context of this protocol. Additional information about the clinical experience to date and possible risks associated with treatment using CAB can be found in the Summary of Data and Guidance for the Investigator section of the IB.

<b><u>Potential Risk of Clinical Significance</u></b>	<b><u>Summary of Data/Rationale for Risk</u></b>	<b><u>Mitigation Strategy</u></b>
<p><b>Drug Induced Liver Injury (DILI)</b></p>	<p>Less than 1% of participants in the CAB program to date have developed transaminitis (elevated liver transaminases characterised by predominant alanine aminotransferase (ALT) elevation). In most participants, transient transaminitis was explained by acute hepatitis C infection (majority) and other systemic infections. In a small number of participants, there was not an alternative explanation, suggesting a mild form of drug induced liver injury (DILI) without hepatic dysfunction, which resolved upon withdrawal of treatment with CAB.</p>	<ul style="list-style-type: none"> <li>• Exclusion criteria as described in Section 5.2 will prohibit participants with significant liver impairment based on screening liver chemistry including transaminases (ALT and Aspartate aminotransferase [AST]) as well on prior medical history. Participants with a history of chronic liver disease with ongoing inflammation and/or fibrosis will have additional confirmatory assessments to confirm suitability for entry into the study.</li> <li>• A 4-week oral lead- in Phase is being implemented in this study, where all participants will receive oral CAB prior to the administration of IM CAB to assess individual safety and tolerability</li> <li>• Liver transaminases (ALT and AST) will be monitored throughout this study (refer to Time &amp; Events Table, Section 7.1) and the liver chemistry stopping criteria will be adopted as described in Section 5.5.1.1 of this protocol. Participants will be withdrawn from CAB treatment where no compelling alternative cause is identified and DILI is suspected.</li> </ul>

<b><u>Potential Risk of Clinical Significance</u></b>	<b><u>Summary of Data/Rationale for Risk</u></b>	<b><u>Mitigation Strategy</u></b>
		<ul style="list-style-type: none"> <li>• Participants who develop ALT <math>\geq 3</math> times the upper limit of normal (ULN) while on study must consult with Medical Monitor prior to initiation or continuation of CAB LA + RPV LA.</li> </ul>
<p><b>Injection Site Reactions (ISRs)</b></p>	<p>Clinical, experience to date has demonstrated ISRs occur in the majority of exposed participants treated with CAB LA but are generally mild (Grade 1) or moderate (Grade 2) and include events of pain, tenderness, erythema, or nodule formation of several days duration (median duration for individual events &lt;1 week).</p> <p>ISRs may occur more than once in an individual participant receiving multiple injections. Although some Grade 3 ISRs were reported, overall ISRs have been well tolerated and have not to date been associated with an excess of participants' withdrawal.</p> <p>None of the ISRs reported to date have been serious.</p>	<ul style="list-style-type: none"> <li>• Administration advice will be given to minimize risk of poor administration technique giving rise to injection site reactions. Advice on care, monitoring, natural course, and treatment of ISRs is given in study documentation</li> <li>• Advice will be given to participants on care of injection site on day/days immediately post administration, use of analgesia, compresses where appropriate.</li> <li>• Participants will be closely monitored for ISRs particularly for signs of pain, tenderness, infections, erythema, swelling, induration, or nodules (granulomas or cysts) throughout the study.</li> <li>• Complications of ISRs such as infections (abscess, cellulitis) and collections of fluid requiring drainage will be monitored</li> </ul>

<b><u>Potential Risk of Clinical Significance</u></b>	<b><u>Summary of Data/Rationale for Risk</u></b>	<b><u>Mitigation Strategy</u></b>
		<ul style="list-style-type: none"> <li>• Significant ISRs may be photographed and referred to a dermatologist for specialist advice.</li> </ul>
<p><b>Hypersensitivity Reactions (HSR)</b></p>	<p>Hypersensitivity reactions have been reported as uncommon occurrences with integrase inhibitors, including the closely related compound dolutegravir, and were characterized by rash, constitutional findings, and sometimes, organ dysfunction, including liver injury.</p> <p>While there have been no clinical cases of hypersensitivity to CAB to date, there is a theoretical risk of systemic or severe hypersensitivity reactions with or without hepatic symptoms associated with use of IM CAB. The long exposures anticipated after IM CAB injection may complicate the management of a drug hypersensitivity reaction, were it to occur.</p>	<ul style="list-style-type: none"> <li>• The risk of developing a hypersensitivity reaction post administration of IM CAB will be minimized by the use of a 4-week oral lead-in of oral CAB to determine individual safety and tolerability prior to the introduction of IM CAB.</li> <li>• Clinical assessments, laboratory tests (including liver transaminases) and vital signs will be performed throughout this study (refer to Time &amp; Events Table, Section 7.1). Results from these assessments may aid early detection of HSR.</li> <li>• Oral CAB will be withdrawn immediately for cases with suspected HSR during the oral CAB lead-in phase and would not proceed to the injection phase. Participants in the injection phase would not receive further injections. During oral and IM CAB treatment, any HSR reactions that occur would be managed supportively.</li> </ul>

<u>Potential Risk of Clinical Significance</u>	<u>Summary of Data/Rationale for Risk</u>	<u>Mitigation Strategy</u>
<p><b>Effects in pregnancy seen in non-clinical studies</b></p>	<p>In animal reproduction studies, CAB when administered to rats at &gt; 30 times the systemic exposure at the maximum recommended oral human dose (MRHD) of 30 mg during organogenesis through delivery, had adverse effects on labor and delivery that may be related to a delay in the onset of parturition, resulting in increased fetal mortality (stillbirths) and neonatal deaths immediately after birth.</p> <p>A delay in the onset of parturition, increased stillbirths and neonatal deaths were observed in a rat pre- and postnatal development study at greater than 30 times the exposure at the recommended human dose (RHD). No evidence of adverse developmental outcomes was observed with oral cabotegravir in rats or rabbits (greater than 30 times or similar to (approximately 0.7 times) the exposure at the RHD, respectively) given during organogenesis.</p> <p>The clinical significance of these finding in humans is unknown.</p> <p>For pregnant participants remaining in the study, refer to <a href="#">Appendix 11</a> for additional data regarding CAB and pregnancy.</p>	<ul style="list-style-type: none"> <li>• Pregnant females are excluded from enrollment in this study and women of childbearing potential (WOCBP) are required to adopt highly reliable means of contraception during participation, and throughout the long term follow up phase of this study following exposure to CAB LA.</li> <li>• WOCBP are also required to undergo regular pregnancy testing throughout study conduct. Pregnant participants who remain in the study do not need pregnancy testing for the duration of the pregnancy</li> <li>• Participants who become pregnant during the study may remain in the study provided all protocol defined pregnancy related assessments, procedures and documentation are completed, and a pregnancy specific ICF addendum is signed by the participant. Details regarding management of pregnant participants are found in <a href="#">Appendix 11</a>.</li> </ul>

<b><u>Potential Risk of Clinical Significance</u></b>	<b><u>Summary of Data/Rationale for Risk</u></b>	<b><u>Mitigation Strategy</u></b>
	<p>Female participants on LA dosing who become pregnant will have exposures throughout pregnancy due to the long half-life and PK tail of CAB/RPV. Pregnant participants who are withdrawn from study and are initiated on an alternative oral ART regimen consisting of either 2 or 3 antiretrovirals to protect the life of the mother and for the prevention of MTCT, potentially expose the fetus to additional ARVs during gestation (in some cases upwards of 5 antiretrovirals).</p>	
<p><b>Potential effects in females exposed to dolutegravir during conception and early pregnancy</b></p>	<p>A preliminary analysis of an ongoing birth outcome surveillance study in Botswana involving women exposed to dolutegravir (DTG), a different molecule in the same integrase class of medications as CAB, identified four cases (as of May 2018) of neural tube defects in 426 infants born to mothers who were exposed to DTG-containing regimens from the time of conception. In the same study, no infant born to a woman who started DTG during pregnancy had a neural tube defect, out of 2,824 women. A causal relationship of these events to the use of DTG has not been established. The incidence of neural tube defects in the general population ranges</p>	<ul style="list-style-type: none"> <li>• Pregnant females are excluded from enrollment in clinical trials of CAB at this time and women of childbearing potential (WOCBP) are required to adopt highly reliable means of contraception during participation and throughout long term follow up phases of studies after exposure to CAB LA.</li> <li>• WOCBP also undergo regular pregnancy testing throughout study conduct. Pregnant participants who remain in the study do not need pregnancy testing for the duration of the pregnancy. It should be noted that CAB concentration could remain for prolonged</li> </ul>

<b><u>Potential Risk of Clinical Significance</u></b>	<b><u>Summary of Data/Rationale for Risk</u></b>	<b><u>Mitigation Strategy</u></b>
	<p>from 0.5-1 case per 1,000 live births. As neural tube defects occur within the first 4 weeks of fetal development (at which time the neural tubes are sealed) this potential risk would concern women exposed to DTG at the time of conception and in early pregnancy.</p> <p>Recently updated data (April 2020) for this birth outcome study showed that among women who were on DTG when they became pregnant, 7/3591 neural tube defects (NTD) occurred (0.19%). In comparison, NTDs were identified in 21/19,361 (0.11%) women delivering on any non-DTG antiretrovirals. There was not a significant difference in the number of neural tube defects between births to women taking DTG and those taking other non-DTG antiretroviral treatments (0.09% difference).</p> <p>The clinical relevance of either of these findings in relation to CAB use is unknown</p>	<p>periods despite discontinuation of CAB LA</p> <ul style="list-style-type: none"> <li>Participants who become pregnant during the study may remain in the study, provided all protocol defined pregnancy related assessments, procedures and documentation are completed and a pregnancy specific ICF addendum is signed by the participant. Details regarding management of pregnant participants is found in <a href="#">Appendix 11</a>.</li> </ul>
<p><b>Development of Resistance following discontinuation of CAB LA</b></p>	<p>Residual concentrations of CAB would remain in the systemic circulation of participants who stop CAB LA treatment for prolonged periods (more than 1 year, in some subjects, GlaxoSmithKline Document Number <a href="#">2016N269422_00</a>) after last injection (e.g., for tolerability issues or treatment</p>	<ul style="list-style-type: none"> <li>After participants stop CAB LA, Oral HAART regimens will be prescribed within 4 weeks after the last Q4W dose or within 8 weeks after the last Q8W dose, and following consultation with the medical monitor. This would be anticipated to result in continued suppression or</li> </ul>



<b><u>Potential Risk of Clinical Significance</u></b>	<b><u>Summary of Data/Rationale for Risk</u></b>	<b><u>Mitigation Strategy</u></b>
	<p>failure). Participants discontinuing CAB LA regimen may be at risk for developing HIV-1 resistance to CAB many weeks after discontinuing injectable therapy.</p>	<p>rapid resuppression of HIV-1 RNA thus minimizing the risk of emergent resistance</p> <ul style="list-style-type: none"> <li>• The Sponsor will continue to monitor participants in this study who discontinue a LA regimen for a minimum of 52 weeks from the time of the last LA administration.</li> </ul>
<p><b>Drug-Drug Interactions (DDIs)</b></p>	<p>For a complete listing of permitted and prohibited concurrent medications for CAB and CAB LA, refer to Section 6.13</p> <p>CAB and CAB LA should not be co-administered with the following medicinal products, as significant decreases in CAB plasma concentrations may occur (due to UGT enzyme induction), which may result in loss of therapeutic effect of CAB.</p> <ul style="list-style-type: none"> <li>- the anticonvulsants carbamazepine, oxcarbazepine, phenobarbital, phenytoin</li> <li>- the antimycobacterials rifampicin, rifapentine, rifabutin</li> <li>- St John’s wort (Hypericum perforatum)</li> </ul> <p>Oral CAB administration only: Antacid products</p>	<ul style="list-style-type: none"> <li>• All participants will be informed of prohibited medications throughout the study and updates provided as needed via the informed consent.</li> </ul>

<u>Potential Risk of Clinical Significance</u>	<u>Summary of Data/Rationale for Risk</u>	<u>Mitigation Strategy</u>
	<p>containing divalent cations (e.g., aluminum, calcium, and magnesium) must be taken at least 2 hours before or at least 4 hours after CAB.</p> <p>Participants discontinuing a LA regimen may be at risk for developing DDIs many weeks after discontinuing injectable therapy.</p>	
<p><b>Inadvertent Intravenous Injection (Accidental Maladministration)</b></p>	<p>As with any intramuscular injection, it is possible that CAB LA can be inadvertently administered intravenously instead of intramuscularly possibly resulting in higher than expected concentrations of CAB shortly after injection and lower concentrations thereafter. This could be due to administrator error, improper injection technique and / or improper needle length used based on body type.</p> <p>The clinical consequences of overdose with CAB LA are currently unknown. HIV-1 viral suppression may not be effective following accidental maladministration.</p>	<ul style="list-style-type: none"> <li>• Training will be provided to all sites on proper injection technique.</li> <li>• Should IM maladministration be suspected at any time (e.g. suspected under or overdose or inadvertent IV dosing), a post dose electrocardiogram (ECG), vital signs, or any other supportive testing may be obtained at the discretion of the investigator, and the medical monitor will be notified.</li> <li>• Laboratory samples for safety parameters and HIV-1 RNA will be closely monitored in all participants. Additionally, 2 hour post dose PK samples will be obtained at a few early timepoints for determination of CAB concentration and possible pharmacokinetic correlation with safety parameters such as ECG changes and virologic response. Additionally, an unscheduled PK sample may be drawn approximately 2 hours post dosing for future evaluation of CAB concentrations.</li> </ul>

**ORAL RPV**

For safety and risk mitigation for oral RPV refer to the RPV local prescribing information .

**RPV LA**

Information about the clinical experience to date and possible risks associated with treatment using RPV LA can be found in the Summary of Data and Guidance for the Investigator section of the IB. Systemic reactions following RPV LA injections have been observed in clinical trials. These occur infrequently (in less than 0.5% of participants) and typically begin to resolve within minutes of the injection however, some participants required supportive care. Where timely PK data was available, high RPV PK plasma concentrations have been observed which may have resulted from an accidental partial IV injection of RPV. The following risks are considered to be of specific clinical relevance in the context of IM use.

<b><u>Potential Risk of Clinical Significance</u></b>	<b><u>Summary of Data/Rationale for Risk</u></b>	<b><u>Mitigation Strategy</u></b>
<b>Injection Site Reactions</b>	Clinical, experience to date has demonstrated ISRs occur in the majority of exposed participants treated with RPV LA but are generally mild (Grade 1) or moderate (Grade 2) and include events of pain, tenderness, erythema, or nodule formation of several days duration (median duration for individual events <1 week). ISRs may occur more than once in an individual participant receiving multiple injections. Although some Grade 3 ISRs were reported, overall ISRs have been well tolerated and have not to date been associated with an excess of participants' withdrawal due to ISRs.	<ul style="list-style-type: none"> <li>• Administration advice to minimize risk of poor administration technique giving rise to injection site reactions. Advice on care, monitoring, natural course, and treatment of ISRs given in study documentation.</li> <li>• Advice to participants on care of injection site on day/days immediately post administration, use of analgesia, compresses where appropriate.</li> <li>• Participants will be closely monitored for ISRs particularly for signs of pain, tenderness, infections, erythema, swelling, induration, or nodules (granulomas or cysts) throughout the</li> </ul>

<u>Potential Risk of Clinical Significance</u>	<u>Summary of Data/Rationale for Risk</u>	<u>Mitigation Strategy</u>
	<p>None of the ISRs was serious and no clinical significant complications were reported</p>	<p>study.</p> <ul style="list-style-type: none"> <li>• Complications of ISRs such as infections (abscess, cellulitis) and collections of fluid requiring drainage will be monitored</li> <li>• Significant ISRs may be photographed and referred to a dermatologist for specialist advice.</li> </ul>
<p><b>Rash</b></p>	<p>Some observations of rash with oral RPV have been reported in clinical studies executed to date (the majority are Grade 1 or 2).</p> <p>Severe skin and hypersensitivity reactions have been reported during the postmarketing experience, including cases of Drug Reaction with Eosinophilia and Systemic Symptoms (DRESS), with oral RPV containing regimens. While some skin reactions were accompanied by constitutional symptoms such as fever, other skin reactions were associated with organ dysfunctions, including elevations in hepatic serum biochemistries.</p>	<ul style="list-style-type: none"> <li>• In this study, RPV LA administration will be preceded by an oral RPV lead in to evaluate safety and tolerability in individual participants.</li> <li>• Participants with a Grade 1 or 2 rash will be allowed to continue treatment , depending on the clinical judgment of the investigator.</li> <li>• All participants experiencing a Grade 3 or 4 rash should discontinue their ARV medication (study medication and background regimen) and be withdrawn from the study.</li> <li>• All rash events should be assessed with special attention to systemic symptoms, laboratory abnormalities, or mucosal involvement. Close clinical follow-up, including follow-up of laboratory abnormalities, and appropriate medical intervention, including referral to</li> </ul>

<b><u>Potential Risk of Clinical Significance</u></b>	<b><u>Summary of Data/Rationale for Risk</u></b>	<b><u>Mitigation Strategy</u></b>
		<p>dermatologist as appropriate, should be instituted for these events; daily follow-up is recommended for 5 days from the onset of the event to monitor for progression of the event. See Section 7.4.5.13 for additional guidance on management of rash events.</p>
<b>Development of Resistance</b>	<p>Residual concentrations of RPV LA can remain in the systemic circulation of participants who stopped treatment (e.g., for tolerability issues or treatment failure) for prolonged periods (months to more than a year, in some subjects, McGowan, 2016).</p> <p>Participants discontinuing a LA regimen may be at risk for developing resistance to RPV many weeks after discontinuing injectable therapy.</p>	<ul style="list-style-type: none"> <li>• After participants stop RPV LA, Oral HAART regimens will be prescribed within 4 weeks after the last Q4W dose or within 8 weeks after the last Q8W dose, and following consultation with the medical monitor. This would be anticipated to result in rapid resuppression of HIV-1 RNA thus minimizing the risk of emergent resistance</li> <li>• The Sponsor will continue to monitor participants in this study who discontinue a LA regimen for a minimum of 52 weeks from the time of the last LA administration.</li> </ul>
<b>Drug-Drug Interactions (DDIs)</b>	<p>For a complete listing of permitted and prohibited concurrent medications for RPV and RPV LA, refer to Section 6.13</p> <p>RPV LA should not be co-administered with the following medicinal products, as significant decreases in RPV plasma concentrations may occur (due to CYP3A enzyme induction), which</p>	<ul style="list-style-type: none"> <li>• All participants will be informed of prohibited medications throughout the study and updates provided as needed via informed consent.</li> </ul>

<u>Potential Risk of Clinical Significance</u>	<u>Summary of Data/Rationale for Risk</u>	<u>Mitigation Strategy</u>
	<p>may result in loss of therapeutic effect of RPV LA.</p> <ul style="list-style-type: none"> <li>- the anticonvulsants carbamazepine, oxcarbazepine, phenobarbital, phenytoin</li> <li>- the antimycobacterials rifampicin, rifapentine, rifabutin</li> <li>- the glucocorticoid systemic dexamethasone, except as a single dose treatment</li> <li>- St John’s wort (Hypericum perforatum).</li> </ul> <p>Of note, evidence to date indicates that clinically relevant DDIs with RPV LA and other antiretrovirals are unlikely to occur.</p> <p>Oral RPV administration only:</p> <ul style="list-style-type: none"> <li>- Antacid products containing divalent cations (e.g., aluminum, calcium, and magnesium) must be taken at least 2 hours before or at least 4 hours after RPV.</li> <li>- H2-antagonists must be taken at least 12 hours before or at least 4 hours after taking RPV.</li> <li>- RPV should not be co-administered with proton pump inhibitors, such as esomeprazole,</li> </ul>	

<b><u>Potential Risk of Clinical Significance</u></b>	<b><u>Summary of Data/Rationale for Risk</u></b>	<b><u>Mitigation Strategy</u></b>
	<p>lansoprazole, omeprazole, pantoprazole, rabeprazole;</p> <p>Participants discontinuing a LA regimen may be at risk for developing DDIs many weeks after discontinuing injectable therapy.</p>	

<b><u>Potential Risk of Clinical Significance</u></b>	<b><u>Summary of Data/Rationale for Risk</u></b>	<b><u>Mitigation Strategy</u></b>
<p><b>Inadvertent Intravenous Injection (Accidental Maladministration)</b></p>	<p>As with any intramuscular injection, it is possible that RPV LA can be inadvertently administered intravenously instead of intramuscularly possibly resulting in higher than expected concentrations of RPV shortly after injection and lower concentrations thereafter. This could be due to administrator error, improper injection technique and / or improper needle length used based on body type.</p> <p>In addition, HIV-1 viral suppression may not be effective following accidental intravenous maladministration.</p> <p>Systemic reactions following RPV LA injections have been observed in clinical trials. These occur infrequently (in less than 0.5% of participants) and typically begin to resolve within minutes of the injection, however some participants required supportive care. Where timely PK data was available, high RPV PK plasma concentrations have been observed which may have resulted from an accidental partial IV injection of RPV</p>	<ul style="list-style-type: none"> <li>• Training will be provided to all sites on proper injection technique.</li> <li>• Should IM maladministration be suspected at any time (e.g., suspected under or overdose or inadvertent IV dosing), post dose ECG monitoring and vital signs or any other supportive testing may be obtained at the discretion of the investigator, and the medical monitor notified</li> <li>• Laboratory samples for safety parameters and HIV-1 RNA will be closely monitored in all participants. Additionally, 2-hour post dose PK samples will be obtained at a few early timepoints for determination of RPV concentration and possible pharmacokinetic correlation with safety parameters such as ECG changes and virologic response. Additionally, an unscheduled PK sample may be drawn approximately 2 hours post dosing for future evaluation of RPV concentrations.</li> </ul>



<b><u>Potential Risk of Clinical Significance</u></b>	<b><u>Summary of Data/Rationale for Risk</u></b>	<b><u>Mitigation Strategy</u></b>
<b>Other Study Related Risks</b>		
Venipuncture	Participants will be required to have blood samples taken. Risk of bruising, and rarely, infection	<ul style="list-style-type: none"> <li>• Trained personnel will perform venipuncture</li> </ul>
Risks of ECG pad removal	<p>Participants will be required to have ECG tracings recorded periodically throughout the study</p> <p>Some discomfort and rash may occur where the ECG pads are removed.</p>	<ul style="list-style-type: none"> <li>• ECGs will be conducted by appropriately trained personnel and effort made to minimize contact time for application of the pads.</li> </ul>
Risk of Treatment Failure	<p>This study employs a novel 2 drug LA ART maintenance regimen for the treatment of HIV-1 infection that remains experimental. Both IM CAB and RPV have demonstrated antiviral activity in large clinical studies and the two drug combination dosed Q4W has demonstrated sustained antiviral activity in studies 200056, 201584 and 201585 however the efficacy of Q8W dosing remains under evaluation.</p> <p>Doses of the CAB LA and RPV LA have been selected to achieve exposures that are expected to maintain virologic efficacy on the basis of available data with the oral and LA formulations.</p>	<ul style="list-style-type: none"> <li>• Viral loads and CD4+ cell counts will be closely monitored throughout the study (maintenance and extension phases), allowing for early detection of failing treatment. Where confirmed virological failure occurs, participants would be discontinued from study drugs and transferred to an oral HAART regimen.</li> <li>• Plasma samples will be collected throughout the Maintenance Phase for determination of CAB and RPV concentration and possible pharmacokinetic correlation with virologic response.</li> </ul>

<b><u>Potential Risk of Clinical Significance</u></b>	<b><u>Summary of Data/Rationale for Risk</u></b>	<b><u>Mitigation Strategy</u></b>
	<p>Due to administration error, it is possible that a participant could receive an inadequate dose of CAB LA or RPV LA. Sub-therapeutic concentrations of either CAB LA or RPV LA could lead to virologic failure and possibly the development of viral resistance.</p>	

### **2.3.1.1. Other Clinically Relevant Information**

Additional details concerning safety observations from clinical studies and for which a causal association has not been established or which are of minimal clinical significance may be found in the Investigator's Brochures .

#### ***Adverse Events of Special Interest:***

##### Seizure

Several cases of seizure have occurred during the cabotegravir program. These cases have had alternative explanations for their occurrence. Overall, there is not convincing evidence that cabotegravir exposure may be causally associated with seizure or with reduction of seizure threshold, due to the low frequency of reports, the confounders present in the cases received to date and lack of any pre-clinical signal or identified plausible mechanism. However, seizure and seizure-like events are considered as AEs of special interest for CAB. Subjects with an unstable or poorly controlled seizure disorder will be excluded from study participation. All cases of prior seizure history should be discussed with the Medical Monitor prior to enrolment. Report any cases of seizure or seizure like events immediately.

### **2.3.2. Benefit Assessment**

The antiviral activity against HIV-1 of CAB has been well established through Phase 2 and Phase 3 studies. RPV is an established antiviral agent against HIV-1 in treatment naive patients, with long term durability (>96 weeks in Phase 3 and >240 weeks in Phase IIb).

Participants receiving CAB LA + RPV LA are anticipated to benefit from maintenance of virological suppression using LA agents. Participants randomized to receive CAB LA+ RPV LA Q4W or Q8W weekly dosing will not need to take concomitant daily oral therapy. Adherence in these participants is expected to be improved and will be directly observed during IM injections. Efficacy of this two-drug regimen, as IM agents, has been demonstrated through Week 96 of the ongoing 200056, 201584 and 201585 studies. The reduction in ART, and the discontinuation of NRTIs, may offer long term safety and tolerability benefits in these participants.

### **2.3.3. Overall Benefit:Risk Conclusion**

Taking into account the measures taken to minimize risk to participants participating in this study, the potential risks identified in association with CAB LA and RPV LA Q4W and Q8W regimens, and the study as a whole are justified by the anticipated benefits that may be afforded to treatment-experienced patients with HIV-1 infection.

### 3. OBJECTIVES AND ENDPOINTS

Objectives	Endpoints
<b>Primary</b>	
To demonstrate the non-inferior antiviral activity of CAB LA + RPV LA every 8 weeks (every two months) compared to CAB LA + RPV LA every 4 weeks (monthly) over 48 weeks in suppressed HIV-1 infected antiretroviral therapy (ART)-experienced participants	Proportion of participants with plasma HIV-RNA greater than or equal to 50 copies/mL as per Food and Drug Administration (FDA) Snapshot algorithm at Week 48 (Intent-to-Treat Exposed [ITT-E] population)
<b>Secondary</b>	
To demonstrate the antiviral and immunologic activity of CAB LA + RPV LA every 8 weeks compared to CAB LA + RPV LA every 4 weeks	<p>Proportion of participants with plasma HIV-1 RNA &lt;50 c/mL (c/mL) at Week 24, Week 48, Week 96, and Week 152 using the FDA Snapshot algorithm (Intent-to-Treat Exposed [ITT-E] population)</p> <p>Proportion of participants with protocol-defined confirmed virologic failure (CVF) through Week 24, Week 48, Week 96, and Week 152</p> <p>Proportion of participants with HIV-RNA greater than or equal to 50 c/mL as per FDA Snapshot algorithm at Week 24, Week 96, and Week 152</p> <p>Absolute values and changes from Baseline in viral load and CD4+ cell counts over time including Week 48, Week 96, and Week 152</p>
To evaluate the safety and tolerability of CAB LA + RPV LA every 8 weeks compared to CAB LA + RPV LA every 4 weeks	<p>Incidence and severity of AEs and laboratory abnormalities over time including Week 24, Week 48, Week 96, and Week 152</p> <p>Proportion of participants who discontinue treatment due to AEs over time including Week 24, Week 48, Week 96, and Week 152</p> <p>Change from Baseline in laboratory parameters over time including Week 48, Week 96, and Week 152</p>

Objectives	Endpoints
To assess viral resistance in participants experiencing protocol-defined confirmed virologic failure	Incidence of treatment emergent genotypic and phenotypic resistance to CAB, RPV through Week 24, Week 48, Week 96, and Week 152
To characterize CAB and RPV concentrations and population pharmacokinetics and identify important determinants of variability	<p>Plasma PK parameters for CAB LA and RPV LA (when evaluable, <math>C_{trough}</math>, concentrations post dose [<math>\sim C_{max}</math>], and area under the curve [AUC])</p> <p>Demographic parameters including, but not limited to, age, sex, race, body weight, body mass index, and relevant laboratory parameters will be evaluated as potential predictors of inter- and intra-participant variability for pharmacokinetic parameters</p>
<p>To assess preference for CAB LA + RPV LA every 8 weeks or CAB LA + RPV LA every 4 weeks LA compared to oral antiretroviral (ARV)</p> <p>To assess preference for CAB LA+ RPV LA every 8 weeks compared to CAB LA + RPV LA every 4 weeks</p>	Preference for CAB LA + RPV LA every 8 weeks or CAB LA + RPV LA every 4 weeks compared to oral ARV and preference for CAB LA + RPV LA every 8 weeks compared to CAB LA + RPV LA every 4 weeks will be assessed using a preference questionnaire at week 48 (or Withdrawal).
To assess patient reported health-related quality of life, treatment satisfaction, injection tolerability, and treatment acceptance.	<p>Change from Baseline (Day 1) in HRQoL at Week 24, and Week 48 (or Withdrawal)</p> <p>Change from baseline (Day 1) in total “treatment satisfaction” score, and individual item scores of the HIV Treatment Satisfaction Status Questionnaire (HIVTSQs) at Week 24, 48, and 152 (or Withdrawal)</p> <p>Change in treatment satisfaction over time using the HIV Treatment Satisfaction Change Questionnaire HIVTSQc at Week 48 (or Withdrawal).</p> <p>Change from Week 8 in Dimension scores (“Bother of ISRs”, “Leg movement”, “Sleep”, and “Injection Acceptance”) and individual item scores assessing pain during injection, anxiety before and after injection, willingness to be injected in the future and overall satisfaction with mode of</p>

Objectives	Endpoints
	<p>administration over time will be assessed using the Perception of iNjection questionnaire (PIN) at Weeks 8, 24, 48 and 152 (or Withdrawal)</p> <p>Change from Baseline (Day 1) in treatment acceptance at Weeks 24, 48 and 152 (or Withdrawal) will be assessed using the “General acceptance” dimension of the Chronic Treatment Acceptance (ACCEPT) questionnaire</p>
Exploratory	
<p>To evaluate the antiviral and immunologic effects, safety and tolerability, and viral resistance of CAB LA + RPV LA for all participants in the Extension Phase.</p>	<p>Proportion of participants with plasma HIV-1 RNA &lt;50 c/mL over time</p> <p>Proportion of participants with confirmed virologic failure over time</p> <p>Incidence of treatment emergent genotypic and phenotypic resistance to CAB and RPV in over time</p> <p>Incidence and severity of AEs and laboratory abnormalities over time</p> <p>Proportion of participants who discontinue treatment due to AEs over time</p> <p>Absolute values and changes in laboratory parameters over time</p> <p>Incidence of disease progression (HIV-associated conditions, acquired immunodeficiency syndrome [AIDS] and death)</p>
<p>To explore the effect of patient characteristics on virologic and immunologic responses to CAB LA+ RPV LA every 8 weeks compared to CAB LA + RPV LA every 4 weeks</p>	<p>Proportion of participants by patient subgroup(s) (e.g., by age, gender, BMI, race, HIV-1 subtype, Baseline CD4+, type of oral treatment [NNRTI, PI, or INSTI], duration prior CAB LA and RPV LA exposure [0 weeks, 1-24 weeks, &gt; 24 weeks]) with HIV-RNA greater than or equal to 50 c/mL over time including Week 48, Week 96, and Week 152 using the Snapshot algorithm for the</p>

Objectives	Endpoints
	ITT-E population  Change from Baseline in CD4+ cell counts by subgroups at Week 48, Week 96, and Week 152
To explore relationship(s) between plasma concentrations of CAB and RPV and pharmacodynamic endpoints.	Relationship between plasma CAB and RPV concentrations and virologic, immunologic responses, and/or occurrence of adverse events [AEs] over time.
To assess reason for switching using a single question.  To assess reason for continuation using a single question	For patients randomized from oral SOC, the reasons for willingness to switch ART at baseline (Day 1) will be assessed  For patients randomized from CAB LA + RPV LA every 4 weeks in ATLAS, the reasons for willingness to continue long-acting ART at baseline (Day 1) will be assessed
To assess preference for CAB LA + RPV LA every 8 weeks or every 4 weeks compared to daily oral for participants receiving oral bridging during the Maintenance and/or Extension phases	Preference for CAB LA + RPV LA every 8 weeks or every 4 weeks compared to daily oral for participants receiving oral bridging during the Maintenance and/or Extension phases will be assessed using a preference questionnaire at Week 152 or Withdrawal

## 4. STUDY DESIGN

### 4.1. Overall Design

Study 207966 (Antiretroviral Therapy as Long Acting Suppression every 2 Months-ATLAS-2M) is a Phase III, randomized, open-label, active-controlled, multicenter, parallel-group, non-inferiority study designed to assess the antiviral activity and safety of CAB LA + RPV LA administered every 4 weeks compared CAB LA + RPV LA administered every 8 weeks in approximately 1020 adult HIV-1 infected patients.

Two groups of patients who fulfill eligibility requirements will be randomized (1:1) at Day 1 to receive CAB LA + RPV LA Q4W, or CAB LA + RPV LA Q8W regimen for at least 100 weeks:

#### Group 1: Patients randomized from current ART Standard of Care (SOC) therapy

Patients randomized from current ART SOC therapy, including those enrolled to the “current ART” arm of the ATLAS study following completion of the Week 52 visit (at

minimum), will begin oral therapy with CAB 30 mg + RPV 25 mg once daily at Day 1 for 28 days ( $\pm 3$  days) to determine individual safety and tolerability prior to receiving CAB LA + RPV LA Q4W, or CAB LA + RPV LA Q8W. For patients on SOC transitioning from the ATLAS trial, eligibility for ATLAS-2M can be determined once the final central lab results from ATLAS are available and safety parameters have been reviewed.

Group 2: Patients currently receiving CAB LA + RPV LA Q4W

At Day 1, patients entering ATLAS-2M from ATLAS and currently receiving CAB LA + RPV LA Q4W (including both those who were originally randomized to Q4W in the Maintenance phase of ATLAS and those who transitioned from SOC to the Q4W regimen within the Extension Phase of ATLAS) will be randomized 1:1 to either continue Q4W administration or transition to Q8W administration of CAB LA + RPV LA. The first injection visit for ATLAS-2M can be performed once the final central lab results from ATLAS are available and safety parameters have been reviewed, and the ATLAS Week 52 visit (at minimum) has been completed. Participants will continue to receive CAB LA + RPV LA Q4W injections as scheduled within the ATLAS trial until their eligibility for ATLAS-2M can be fully evaluated and the participant is re-randomized (Q4W or Q8W). If determined to be ineligible for ATLAS-2M, those participants can elect to continue participation in ATLAS or withdraw from the ATLAS study.

Participants in ATLAS-2M who successfully complete Week 100 (without meeting study defined withdrawal criteria) will be given the option to continue to receive their randomized treatment (CAB LA + RPV LA administered Q4W or Q8W) in the Extension Phase through Week 152 and until the study treatment is either locally approved and commercially available within the local sector (including through local public/government health sectors), the participant no longer derives clinical benefit, the participant meets a protocol-defined reason for discontinuation or until development of either CAB LA + RPV LA Q4W and/or Q8W is terminated. Alternatively, participants can choose to complete study participation and enter the 52-week LTFU Phase of the study.

Any participant who receives at least one dose of CAB LA and/or RPV LA and discontinues the CAB LA + RPV LA regimen for any reason will enter a 52-week LTFU Phase. Those participants must remain on suppressive highly active antiretroviral therapy (HAART) for at least 52 weeks after the last dose of CAB LA and/or RPV LA.

In order to achieve balance across the treatment arms, randomization will be stratified by prior CAB + RPV Exposure: 0 weeks, 1-24 weeks, >24 weeks. The primary endpoint for the study is the proportion of participants with HIV-RNA greater than or equal to 50 c/mL (Virologic Failure) at Week 48 as per Food and Drug Administration (FDA) Snapshot algorithm using the Intent-to-Treat Exposed (ITT-E) population. The proportion of participants with plasma HIV-1 RNA <50 c/mL at Week 48 using the FDA Snapshot algorithm (Missing, Switch or Discontinuation = Failure, ITT-E population) is a key secondary endpoint comparison.



The sample size of 1020 provides 85% power to demonstrate non-inferiority in the primary endpoint at Week 48 using a 4% margin, assuming a true 3% failure rate for Q8W CAB LA + RPV LA and a 2% failure rate for the Q4W CAB LA + RPV LA arm and a 2.5% one-sided alpha level.

**Figure 1 207966 (ATLAS-2M) Study Design Schematic**

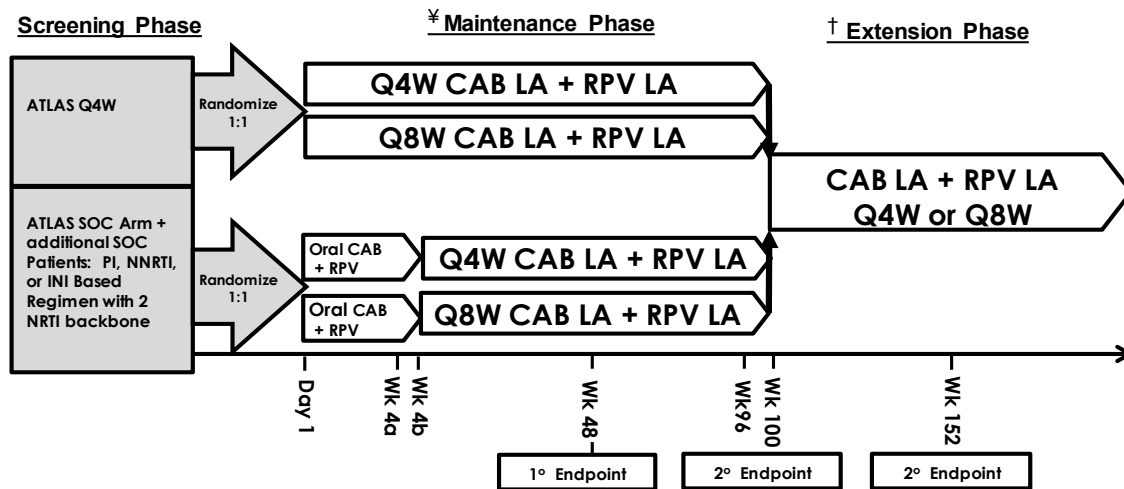

N=1020, randomized 1:1 to each arm and stratified by prior CAB + RPV Exposure  
 # SOC Patients not transitioning from the ATLAS study must be on uninterrupted current regimen (either the initial or second cART regimen) for at least 6 months prior to Screening. Documented evidence of at least two plasma HIV-1 RNA measurements <50 c/mL in the 12 months prior to Screening: one within the 6 to 12 month window, and one within 6 months prior to Screening. No history of virologic failure. No evidence of viral resistance based on the presence of any resistance-associated major INI, or NNRTI mutation (except K103N) from prior genotype assay results. No current or prior history of etravirine use.  
 †Optional Extension Phase to continue randomized CAB LA + RPV LA Q4W or Q8W at Wk 100  
 ‡Participants who withdraw from IM regimen must go into 52 week long term follow up phase if randomized regimen is not yet locally approved and commercially available.

**4.2. Treatment Groups and Duration**

**4.2.1. Screening Phase (Up to 35 days)**

Informed consent must be obtained prior to any study procedures, including any Screening assessment.

Participants will be involved in a Screening period of up to 35 days and may be re-screened once. Participants who are randomized into the trial and subsequently withdrawn from the study, for any reason, may not be re-screened. Participants may be randomized as soon as all eligibility requirements have been confirmed at the site.

For participants transitioning from the ATLAS study, eligibility to transition to ATLAS-2M at Week 52 (at the earliest) will be determined once the final central lab results from ATLAS, following (at minimum) completion of the ATLAS Week 48 visit are available

and safety parameters have been reviewed. Separate Screening Labs will be utilized to inform eligibility for ATLAS-2M; however, in some occasions and upon consultation with the Medical Monitor, individual lab results and safety data from the final visit of the ATLAS study can be considered towards informing eligibility for the ATLAS-2M study as long as all other Screening and eligibility criteria are met.

#### 4.2.2. Maintenance Phase (Day 1 up to Week 100)

There are two ways in which study participants may transition to the LA regimen, either directly from oral SOC or from Q4W dosing from ATLAS.

Table 1 and Figure 2 describe the CAB LA + RPV LA dosing regimens in ATLAS-2M based on the mode of transition.

**Table 1 CAB LA + RPV LA Dosing Regimens in ATLAS-2M**

<b><u>Participants Transitioning from Oral Standard of Care (SOC)</u></b>		
<b>Regimen</b>	<b><u>CAB LA</u></b>	<b><u>RPV LA</u></b>
Q4W	<u>CAB LA:</u> Week 4b: 600 mg (Loading Dose) Week 8 & Q4W thereafter: 400 mg	<u>RPV LA:</u> Week 4b: 900 mg (Loading Dose) Week 8 & Q4W thereafter: 600 mg
Q8W	<u>CAB LA:</u> Week 4b, Week 8, & Q8W thereafter: 600 mg	<u>RPV LA:</u> Week 4b, Week 8, & Q8W thereafter: 900 mg
<b><u>Participants Transitioning from ATLAS Q4W</u></b>		
<b>Regimen</b>	<b><u>CAB LA</u></b>	<b><u>RPV LA</u></b>
Q4W	<u>CAB LA:</u> Day 1 & Q4W thereafter: 400 mg	<u>RPV LA:</u> Day 1 & Q4W thereafter: 600 mg
Q8W	<u>CAB LA:</u> Day 1 & Q8W thereafter: 600 mg	<u>RPV LA:</u> Day 1 & Q8W thereafter: 900 mg
All participants entering ATLAS-2M from an oral SOC regimen will receive a 4-week oral lead-in of CAB+RPV prior to receiving IM injections, except for ATLAS subjects transitioning from Q4W to Q8W injections. These participants previously established safety and tolerability of CAB + RPV within the ATLAS study.		

**Figure 2** ATLAS-2M Treatment Schematic

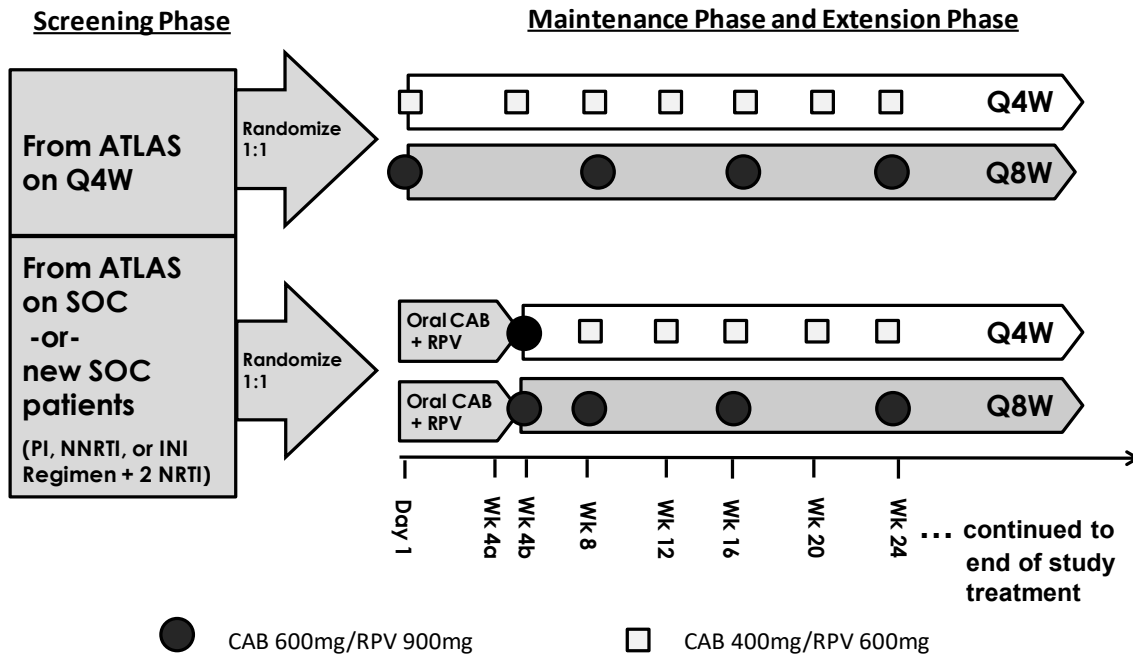

**4.2.2.1. Patients randomized to LA dosing from current ART SOC therapy:**

All participants randomized from current ART SOC therapy (including those transitioning from SOC in ATLAS and new study participants) will begin oral therapy with CAB 30 mg + RPV 25 mg once daily at Day 1 for 4 weeks to determine individual safety and tolerability prior to administration of CAB LA + RPV LA. The oral lead-in period is part of the Maintenance Phase and will therefore be included within the planned analyses.

The final dosing of current daily oral ART regimen should occur the day prior to randomization to avoid overlap of treatment regimens however, if the participant takes current ART prior to coming into the clinic, randomization and initiation of oral CAB and RPV should continue as planned for Day 1. At the Week 4a visit, safety assessments (including e.g., clinical chemistries) will be performed as per the Time and Events Table to determine individual safety and tolerability prior to the initial administration of CAB LA + RPV LA. Dosing of CAB LA + RPV LA Q4W or Q8W will initiate at the Week 4b visit once safety labs from Week 4a are available and have been reviewed.

Subjects receiving oral SOC treatment and randomized to Q4W injections will receive loading doses of CAB LA 600 mg + RPV LA 900 mg on **Week 4b** followed by maintenance injections of CAB LA 400 mg + RPV LA 600 mg every 4 weeks thereafter.

Subjects receiving oral SOC treatment and randomized to Q8W injections will receive doses of CAB LA 600 mg + RPV LA 900 mg on **Week 4b and Week 8** followed by identical maintenance dose injections every 8 weeks thereafter.

All injections should be planned as single injections per drug.

**4.2.2.1.1. IM injections every 4 weeks (Q4W from SOC):**

Week 4b visit only - CAB LA 600 mg + RPV LA 900 mg, each given as 1 X 3 mL IM injection

Week 8 visit and Q4W thereafter - CAB LA 400 mg IM + RPV LA 600 mg IM every 4 weeks for 100 weeks, each given as 1 X 2 mL IM injection

At Week 4b, participants will return to the clinic, take the last oral dose (CAB 30 mg + RPV 25 mg), and receive the first CAB LA (600 mg) + RPV LA (900 mg) injections (within 2 hours of the final oral dose of CAB + RPV). The first injections with IM CAB LA + RPV LA at Week 4b can be performed once central lab results are available and safety parameters are reviewed from the Week 4a visit.

The second and third IM injections with CAB LA 400 mg and RPV LA 600 mg will be performed at Week 8 and Week 12. There will be a -7-day dosing window for the second and third IM injections such that the second injection occurs within the window of Week 7 and Week 8 but no later than Week 8 and the third injection occurs within the window of Week 11 and Week 12 but no later than Week 12. Subsequent injections with CAB LA 400 mg and RPV LA 600 mg will occur every 4 weeks ( $\pm 7$  days) thereafter. In addition, starting after the Week 16 injection, the interval between injection visits will be limited to a maximum of 5 weeks. The Medical Monitor must be contacted to discuss individual participant case management if the length of time between injections exceeds or is projected to exceed 5 weeks.

**4.2.2.1.2. IM injections every 8 weeks (Q8W from SOC):**

Week 4b visit – CAB LA 600 mg + RPV LA 900 mg IM, each given as 1 X 3 mL IM injection

Week 8 visit- CAB LA 600 mg + RPV LA 900 mg IM, each given as 1 X 3 mL IM injection

Week 16 visit and Q8W thereafter - CAB LA 600 mg + RPV LA 900 mg IM, every 8 weeks for 100 weeks, each given as 1 X 3 mL IM injection

At the Week 4b visit, subjects will return to the clinic, take their last oral dose (CAB 30 mg + RPV 25 mg), and receive the first CAB LA (600 mg) + RPV LA (900 mg) injections (within 2 hours of the final oral dose of CAB + RPV). The first injections with IM CAB LA + RPV LA at Week 4b can be performed once central lab results are available and safety parameters are reviewed from the Week 4a visit.

The second loading injection will be administered at Week 8 (CAB LA 600 mg + RPV LA 900 mg, with subsequent injections (CAB LA 600 mg + RPV LA 900 mg) occurring every 8 weeks thereafter. There will be a -7-day dosing window for the second and third IM injections such that the second injection occurs within the window of Week 7 and Week 8 but no later than Week 8 and third injection occurs within the window of Week 15 and Week 16 but no later than Week 16. Subsequent injections with CAB LA 600 mg and RPV LA 900 mg will occur every 8 weeks ( $\pm 7$  days). Starting after the Week 16

injection, the interval between injection visits will be limited to a maximum of 9 weeks. If the length of time between injections exceeds, or is projected to exceed 9 weeks, the Medical Monitor must be contacted to discuss individual participant case management.

#### **4.2.2.2. Participants transitioning from ATLAS and currently receiving CAB LA + RPV LA Q4W**

Subjects receiving Q4W injections within ATLAS and randomized to receive Q4W injections in Study 207966 will continue receiving maintenance injections Q4W as scheduled and will not require a loading dose on Day 1.

Subjects receiving Q4W injections within ATLAS and randomized to receive Q8W injections in Study 207966 will receive doses of CAB LA 600 mg + RPV LA 900 mg on Day 1, one month after their last Q4W maintenance dose, in order to align with Day 1 of study randomization. Subjects will not require an intermediate dose at Week 4 and will receive their next Q8W maintenance injections at Week 8 and Q8W thereafter.

Participants transitioning from the ATLAS study and on CAB LA + RPV LA Q4W treatment will be randomized at Day 1 to either continue Q4W administration or transition to Q8W administration of CAB LA + RPV LA. The first injection visit for the ATLAS-2M study can be performed once the final central lab results from the ATLAS study are available and safety parameters have been reviewed. Screening labs determining eligibility for ATLAS-2M can be collected at Week 48 (at minimum) for participants originally randomized to the Q4W arm within ATLAS. Screening labs for participants who transitioned from SOC to Q4W injections within the ATLAS Extension Phase may be obtained at ATLAS Week 56b (following the CAB + RPV Oral lead-in period) or at subsequent ATLAS visits after receiving one set or a short course of Q4W injections. The transition from the final ATLAS to ATLAS-2M Day 1 dosing must occur 4 weeks ( $\pm 7$  days) from the final injections received in ATLAS

Dosing for participants transitioning from CAB LA + RPV LA Q4W in ATLAS is as follows:

##### **4.2.2.2.1. IM injections every 4 weeks (Q4W from ATLAS Q4W):**

Starting at Day 1, all injections will continue with maintenance doses of CAB LA 400 mg and RPV LA 600 mg administered every 4 weeks ( $\pm 7$  days). In addition, the time between injection visits will be limited to a maximum of 5 weeks. The Medical Monitor must be contacted if the length of time between injections exceeds or is projected to exceed 5 weeks.

##### **4.2.2.2.2. IM injections every 8 weeks (Q8W from ATLAS Q4W):**

Participants transitioning from ATLAS and randomized to receive CAB LA + RPV LA Q8W injections will initiate Q8W dosing at the Day 1 visit as follows:

Day 1- CAB LA 600 mg + RPV LA 900 mg IM, each given as 1 X 3 mL IM injection

Week 8 and Q8W thereafter- CAB LA 600 mg + RPV LA 900 mg IM, each given as 1 X 3 mL IM injection

The second loading injection will be administered at Week 8 (CAB LA 600 mg + RPV LA 900 mg), with subsequent injections (CAB LA 600 mg + RPV LA 900 mg) occurring every 8 weeks thereafter. There will be a -7-day dosing window for the second and third IM injections such that the second injection occurs within the window of Week 7 and Week 8 but no later than Week 8 and third injection occurs within the window of Week 15 and Week 16 but no later than Week 16. Subsequent injections with CAB LA 600 mg and RPV LA 900 mg will occur every 8 weeks ( $\pm 7$  days). Starting after the Week 16 injections, the interval between injection visits will be limited to a maximum of 9 weeks. If the length of time between injections exceeds, or is projected to exceed 9 weeks, the Medical Monitor must be contacted to discuss individual participant case management.

The primary study analysis will consist of data collected through the Week 48 visit. A single repeat of HIV-1 RNA for any participant with a HIV-1 RNA  $\geq 50$  c/mL at Week 48, Week 96, or Week 152 must be performed. The retest should be scheduled as soon as possible (but no later than 4 weeks from the Week 48, 96 or 152 visits, respectively) and will inform the Week 48, 96, or 152 virological endpoint, respectively.

#### **4.2.3. Extension Phase**

Participants who successfully complete 96 Weeks of CAB LA + RPV LA treatment in the Maintenance Phase will continue to have access to their randomized treatment Q4W or Q8W CAB LA + RPV LA in the Extension Phase through Week 152 and until study treatment is either locally approved and commercially available within the local sector (including through local public/government health sectors), the participant no longer derives clinical benefit, the participant meets a protocol-defined reason for discontinuation or until development of either CAB LA + RPV LA Q4W and/or Q8W is terminated. For participants randomized to Q4W arm, dosing visits will continue to occur every 4 weeks with CAB LA 400 mg and RPV LA 600 mg. For participants randomized to the Q8W arm, dosing visits will continue to occur every 8 weeks with CAB LA 600 mg and RPV LA 900 mg. Safety and efficacy assessments will be conducted as per the Time and Events Schedule.

Participants choosing to not enter the Extension phase can complete their study participation at the Week 100 visit and enter into the LTFU Phase as required.

Participants who choose to continue on to the Extension Phase will need to be assessed for eligibility and will continue on their current CAB LA + RPV LA regimen while eligibility is being confirmed. A single repeat of HIV-1 RNA for any participant with a HIV-1 RNA  $\geq 50$  c/mL and  $< 400$  c/mL at Week 96, or Week 152 must be performed. The retest should be scheduled as soon as possible (but no later than 4 weeks from the Week 96 or Week 152 visit). Participants with HIV-1 RNA  $< 50$  c/mL upon retest are eligible to enter the Extension Phase. Participants with HIV-1 RNA  $\geq 400$  c/mL at Week 96 are not eligible to enter the Extension Phase, will not be allowed a repeat to determine eligibility, and will therefore be withdrawn from the study. Eligibility to enter the Extension Phase for any participants with a retest HIV-1 RNA  $> 50$  c/mL and  $< 400$  c/mL will require approval by the study Medical Monitor.

Participants not eligible to enter the Extension Phase or choosing not to participate in the Extension Phase will end their study treatment and enter the LTFU Phase. Sites may be reimbursed for up to a one-month supply of antiretroviral medication to facilitate transition to non-study ART for participants that do not qualify for the Extension Phase.

#### 4.2.4. LTFU Phase – IM Regimen Only

- Any participant who receives at least one dose of CAB LA and/or RPV LA and discontinues the CAB LA + RPV LA regimen for any reason before CAB LA + RPV LA marketed product is locally available must enter the LTFU Phase. Participants must remain on suppressive HAART for at least 52 weeks after the last dose of CAB LA and/or RPV LA in order to prevent selective pressure on HIV and the potential for selection of resistant mutants. **Investigators must discuss the choice of the follow-up HAART regimen with the Medical Monitor prior to initiating the new regimen with the participant. HAART therapy should be initiated within 4 weeks ( $\pm$  7 days) after the last Q4W injection or within 8 weeks ( $\pm$  7 days) after the last Q8W injection.** The LTFU will begin the day of the last CAB LA and/or RPV LA dose and continue for 52 weeks. These participants will complete Withdrawal assessments and will then enter into the LTFU Phase as per the Time and Events Schedule. In addition, for participants who withdraw during the LTFU Phase, the final visit will be considered the study withdrawal visit.
- Where the CAB LA + RPV LA marketed product is locally available, only participants that discontinue the CAB LA + RPV LA regimen for **safety-related reasons** included in Section 5.5 must enter the LTFU Phase. Participants must remain on suppressive HAART for at least 52 weeks after the last dose of CAB LA and/or RPV LA in order to prevent selective pressure on HIV and the potential for selection of resistant mutants. **Investigators must discuss the choice of the follow-up HAART regimen with the Medical Monitor prior to initiating the new regimen with the participant. HAART therapy should be initiated within 4 weeks ( $\pm$  7 days) after the last Q4W injection or within 8 weeks ( $\pm$  7 days) after the last Q8W injection.** The LTFU Phase will begin the day of the last CAB LA and/or RPV LA dose and continue for 52 weeks. These participants will complete Withdrawal assessments and will then enter into the LTFU Phase as per the Time and Events Schedule. In addition, for participants who withdraw during the LTFU Phase, the final visit will be considered the study withdrawal visit.
- NOTE: Participants transitioning to CAB+RPV LA marketed product or alternative HAART (except due to safety-related reasons) do not need to enter the LTFU Phase however the transition plan to marketed product (either CAB+RPV LA or alternative HAART) should be done in consultation with the Central Study Team and the Medical Monitor.

Participants will be assessed with clinic visits at months 3, 6, 9, and 12 during the LTFU Phase. Female participants of child bearing potential must continue to use adequate contraception methods (see Study Procedures Manual for list of accepted forms of contraception) for the entire year of follow up.

In order to assure that participants have access to HAART during the LTFU Phase, GSK may supply HAART regionally or reimbursement will be provided as needed during this phase. The LTFU Phase may be shortened or terminated at any time during the study for various reasons, e.g., better understanding of risks of development of resistance as CAB and RPV exposures decline, regulatory approval and commercial availability, end of study timings, etc.

This phase is considered study participation and participants will be followed on study during this time. A withdrawal visit is not required for participants who do not complete the LTFU Phase. The participants' last on study visit will be considered as their withdrawal visit.

#### **4.2.5. Dose Modifications:**

No dose reductions, modifications, or changes in the frequency of any components of each regimen will be allowed during the study beyond what is allowed within the protocol or directly approved by the study Medical Monitor. Protocol waivers or exemptions are not allowed. Therefore, adherence to the study design requirements is essential and required for study conduct.

In exceptional circumstances, and in consultation with the Medical Monitor, Investigators may provide oral CAB and/or RPV as a short-term “bridging” strategy for participants who have begun CAB LA + RPV LA (see Section 6.8.1 for additional details). Should a participant need “oral bridging”, sites must contact the Medical Monitor for guidance on treatment strategies prior to a missed CAB LA + RPV LA dose. Should a participant not notify the site in advance, the Medical Monitor must be contacted for further treatment guidance.

Please refer to [Appendix 10](#) in Section 11.10 for study management information during the COVID-19 pandemic.

Supplementary study conduct information not mandated to be present in this protocol is provided in the accompanying Study Procedures Manual (SPM), which is available on the online Study Web Portal. The SPM will provide the site personnel with administrative and detailed technical information.

#### **4.2.6. Independent Data Monitoring Committee**

An Independent Data Monitoring Committee (IDMC) will be instituted to ensure external objective medical and/or statistical review of efficacy and safety in order to protect the ethical interests and well-being of subjects and to protect the scientific validity of this study.

The IDMC will evaluate accumulating efficacy, tolerability, safety and PK of CAB LA + RPV LA Q8W at predetermined times during the study. An interim futility analysis will be performed for the IDMC to evaluate the efficacy of CAB LA + RPV LA Q8W prior to the final analysis. Full details of the methods, timing, decision criteria, and operating characteristics will be pre-specified in the IDMC Charter.



The interim futility analysis will be performed with the intent of having approximately 50% of participants reaching Week 24 and providing sufficient lead time to allow the IDMC to review the data prior to any participants reaching the Week 52 visit. A futility rule based on Bayesian posterior predictive probability approach will be applied to assess the probability that the CAB LA + RPV LA Q8W injectable regimen demonstrates non-inferiority to the CAB LA + RPV LA Q4W regimen, given the partial data set. The sponsor will remain blinded to this analysis.

In addition, the IDMC may also monitor the incidence of participants meeting Confirmed Virologic Failure (CVF) criteria through Week 48 to ensure that participants are not being sub-optimally treated in the CAB LA + RPV LA Q8W arm.

Full details of the analyses, estimated timing, and the decision criteria that will be used to determine regimen performance will be pre-specified in the IDMC Charter.

### **4.3. Type and Number of Participants**

The target population to be enrolled is HIV-1 infected virologically suppressed (HIV-1 RNA <50 c/mL) patients on stable antiretroviral therapy (ART) including participants who have completed at minimum, Week 52, of the 201585 (ATLAS) study.

It is anticipated that approximately 1020 participants will be enrolled into ATLAS-2M. In addition to participants rolled over from the ATLAS study, additional participants on SOC treatment will be screened to supplement enrollment such that the study can be appropriately powered (See Section 9.1). A 15% screen failure rate, for additional patients randomized from SOC treatment is anticipated. Participants will be enrolled from multiple countries which may include those countries actively participating in the ATLAS study including Argentina, Canada, France, Germany, Italy, Mexico, Russia, South Africa, South Korea, Spain, Sweden, and the United States.

Randomization will be stratified by prior CAB + RPV Exposure: 0 weeks, 1-24 weeks, >24 weeks. A goal of this study is to enroll populations who are underrepresented in clinical studies, including approximately 25% women. To provide sufficient data to determine whether either gender is correlated with treatment response, sites are expected to take into account gender in their screening strategies.

### **4.4. Scientific Rationale for Study Design**

The design of this study (1:1 randomized, open-label, active-controlled, multicenter, parallel group, non-inferiority study) is well established for confirming the non-inferiority of an investigational agent compared with an active comparator and is generally accepted by regulatory authorities as rigorous proof of antiviral activity. The primary endpoint, proportion of participants defined as virologic failures by the FDA Snapshot algorithm is recommended in the FDA's 2015 guidance document (FDA, 2015) for assessing efficacy in Switch Trials. The key secondary endpoints, proportion with plasma HIV-1 RNA <50 c/mL at Week 48, Week 96, and Week 152, is also a well-established surrogate endpoint for prognosis of HIV-1 infection and disease progression. The Extension Phase will allow for a collection of longer term efficacy, safety and tolerability data for CAB LA + RPV LA Q4W and Q8W regimens.

Various approaches to simplify a patient's antiretroviral therapy (ART) regimen, after achieving viral suppression, have been studied. Previous studies have evaluated switches to ritonavir-boosted PI monotherapy therapy in virologically suppressed patients [Bierman, 2009 and Arribas, 2012]. While the data from these studies have shown both long-term non-inferiority and inferiority to continual Highly Active Antiretroviral Therapy (HAART), they suggest that simplifying from a three drug dual class regimen to a single boosted protease inhibitor may be a safe and effective option for the majority of participants studied who have effectively maintained viral suppression.

The 200056 (LATTE-2) (GlaxoSmithKline Document Number [2013N168152\\_05](#)) clinical trial evaluated a different simplification approach and served as proof of concept for ATLAS-2M. In 200056, HIV-1 RNA suppression was induced with a three drug antiretroviral regimen consisting of CAB + ABC/3TC FDC, and then participants switched to a two-drug two-class regimen consisting of CAB LA + RPV LA for the maintenance of HIV-1 RNA suppression. Results demonstrate that through 96 weeks on two-drug maintenance therapy, 94% (Q8W IM arm) and 87% (Q4W IM) of subjects maintained virologic suppression (HIV-1 RNA <50 c/mL) compared to 84% of subjects continuing oral CAB + 2 NRTIs. CAB LA + RPV LA was well tolerated through Week 96 for both the Q8W and Q4W dosing regimens, as demonstrated by a low discontinuation rate due to AEs, including injection site reaction (ISR) related AEs in either dosing arm, with no significant dose-dependent trends in safety parameters. On the basis of 200056 Week 48, and Week 96 data, Q4W and Q8W IM dosing have been progressed into Phase 3 for further clinical development, respectively. The CAB LA + RPV LA Q4W regimen is currently under evaluation in the ongoing Phase 3 201584 and 201585 studies.

The open-label design best suits the objectives of this study. A double-dummy design could not be undertaken given the logistical challenges of blinding each regimen. Because 2 injections of each investigational product are administered at every visit, a double-dummy design would require all subjects to chronically receive 4 injections per Q4W visit (2 active and 2 placebo), which could be intolerable for patients. In addition, the volume of CAB LA and RPV LA injections will differ significantly between Q8W and Q4W IM injections (3 mL vs 2 mL each), it would not be logistically feasible to blind site staff nor patients from the study treatments being administered.

Participants randomized to receive CAB LA + RPV LA Q8W IM administration will be required to participate in clinic visits approximately every 8 weeks while participants randomized to receive Q4W IM administration will be required approximately monthly clinical visits. Importantly, secondary objectives of this study are to understand the acceptability, tolerability, and patient reported preferences to these novel injectable regimens. An unblinded study design supports collection of participant preference data in a way that would not be possible if a double-blind, double-dummy design were implemented. If the Q8W arm were required to receive blinded placebo injections every month, the value of comparing safety, tolerability, and convenience of Q8W compared to Q4W administrations would be limited and include overly burdensome visit requirements for those randomized to Q8W administration. Additionally, the perceived value for participants to transition from the ATLAS study to ATLAS-2M for potential randomization to the Q8W regimen would also be limited and may result in loss of

patients with prior Q4W experience, thereby limiting the ability to compare experience of Q4W and Q8W regimens within individual patients.

Due to the complexities, lack of feasibility and limitations of blinding CAB LA and RPV LA injections for Q8W compared to Q4W administration, this Phase 3b study is planned as open label.

To maintain the integrity of the trial, data aggregated by actual treatment group will not be made available to members of the Study Team in advance of the first planned sponsor analysis when all subjects have completed Week 24 (see Section 9.2.3.1) and will not be shared with Investigators until the primary analysis at Week 48. In addition, central randomization will be used to ensure that selection bias is avoided (see Section 6.2). Lastly, ascertainment bias affecting the primary efficacy analysis is unlikely since the primary endpoint is inherently objective, being primarily determined by HIV-1 RNA laboratory assessment. The open label design should therefore have no impact on the analysis of study endpoints.

## **4.5. Dose Justification**

### **4.5.1. Oral Lead-In Phase**

Participants entering the study from oral SOC will receive oral CAB 30 mg + RPV 25 mg once daily during the 4-week oral lead-in phase to confirm tolerability prior to receiving CAB LA + RPV LA injectable treatment. Data from study LAI116181 [GlaxoSmithKline Document Number 2011N130484\_00] have demonstrated that there is no clinically relevant drug-drug interaction following repeat oral administration of CAB with RPV. Oral RPV 25 mg once daily, the approved oral dose of RPV, has been administered in combination with oral CAB to HIV-infected participants in Phase 2b studies LAI116482 [(LATTE); GlaxoSmithKline Document Number 2014N216014\_00] (CAB 10, 30, or 60 mg once daily) and 200056 [LATTE-2] (CAB 30 mg, oral lead-in phase). The CAB 30mg oral dose was selected based on observed safety and efficacy from the LATTE-2 study for use during the oral lead phase of Phase 3 studies 201585 [ATLAS] and 201584 [FLAIR] which are evaluating Q4W dosing of CAB LA + RPV LA. The present study will also use CAB 30 mg once daily with RPV 25 mg once daily during the oral lead-in phase.

CAB demonstrated good short-term safety/tolerability and antiviral activity as monotherapy following oral administration of 5 mg and 30 mg once daily. LAI116482 (LATTE) Phase IIb, dose-ranging study (randomized 1:1:1: to CAB 10 mg, 30 mg, or 60 mg) evaluating the long-term efficacy and safety of a two-drug, two-class, once daily combination of CAB + RPV in HIV-infected, treatment-naïve adult participants. Following a 24-week phase of induction of virologic suppression using CAB + 2 NRTIs, the regimen was simplified to oral CAB + RPV once daily at Week 24 and continued for an additional 72-weeks (total comparative study duration of 96 weeks; Margolis, 2015). The results of this study also informed the Phase IIb study 200056 (LATTE-2) with intramuscular CAB LA and RPV LA.

Comparable efficacy, safety, and tolerability were observed across all three CAB doses at the early dose selection and confirmation visits at Week 16 and 24 in LATTE. The

proportion of participants who achieved the primary endpoint of HIV-1 RNA <50 c/mL (Missing, Switch, Discontinuation=Failure [MSDF] algorithm) at Week 48 (24 weeks on Maintenance) remained consistently high across the CAB dose arms ( $\geq 80\%$ ) with a low rate of confirmed virologic failure (Table 2). Across all dose arms, CAB achieved similar efficacy at Week 24 of Induction when co-administered with 2 NRTIs and at Week 96 when co-administered with RPV 25 mg once daily (72 weeks on Maintenance). Rates of virologic suppression through Week 96 (Maintenance) on the two-drug regimen remained similar to that attained through Week 24 (Induction) on three-drug ART.

**Table 2 Proportion (95% CI) of Participants with Plasma HIV-1 RNA <50 c/mL at Key Visits - Snapshot (MSDF) Analysis (ITT-E Population) in LATTE**

Visit		CAB 10 mg N=60	CAB 30 mg N=60	CAB 60 mg N=61	CAB Subtotal N=181	EFV 600 mg N=47
Week 16	n (%)	54 (90)	50 (83)	53 (87)	157 (87)	46 (74)
	95%CI Proportion	(82, 98)	(74, 93)	(78, 95)	(82, 92)	(63, 85)
Week 24	n (%)	52 (87)	51 (85)	53 (87)	156 (86)	46 (74)
	95%CI Proportion	(78, 95)	(76, 94)	(78, 95)	(81, 91)	(63, 85)
Week 48	n (%)	48 (80)	48 (80)	53 (87)	149 (82)	44 (71)
	95%CI Proportion	(70, 90)	(70, 90)	(78, 95)	(77, 88)	(60, 82)
Week 96	n (%)	41 (68)	45 (75)	51 (84)	137 (76)	39 (63)
	95%CI Proportion	(57,80)	(64,86)	(74, 93)	(69, 82)	(51, 75)

CAB was administered with 2 NRTIs through Week 24 (Induction Phase) of LATTE.

95% CIs are normal approximation confidence intervals.

CAB was well tolerated across all doses studied and none of the doses met pre-defined safety stopping criteria. A good safety and tolerability profile with a low discontinuation rate due to AEs was observed in all three dose arms with no significant dose-dependent trends in safety parameters.

Although CAB 30 mg was already selected based on short-term efficacy and safety through Week 24, the observed durability of viral suppression through 96 weeks across all doses, provided further support for CAB 30 mg dose selection in Phase 3 and the

present study. In addition, the 30 mg dose achieves CAB plasma trough concentrations that are greater than mean CAB plasma concentrations observed following CAB LA dosing which allows an adequate assessment of safety and tolerability prior to transitioning to the long-acting, Maintenance Phase of the study (Table 3).

CAB has low risk of causing or being a victim of drug-drug interactions, and therefore, the selected 30 mg dose can be safely used with most common concomitant medications without dose adjustment. CAB exposures are not impacted by the presence of food; however, given that it will be co-administered with RPV which requires food for optimal absorption, the recommended intake of oral CAB in the Phase 3 studies is with food at the same time as RPV.

Overall, the efficacy and safety data from the LATTE study, CAB exposure following LA administration, and limited drug-drug interaction potential, support selection of the CAB 30 mg dose for once daily administration with the approved dose of RPV 25 mg once daily during the oral lead-in phase of this study.

**Table 3 Summary of CAB Pharmacokinetic Parameters Following Repeat Oral Administration in HIV-Infected Subjects**

Study	Once Daily Dose	Phase	Plasma CAB PK Parameter (Geometric mean [95%CI] (CVb%))			
			AUC(0- $\tau$ ) ( $\mu\text{g}\cdot\text{h}/\text{mL}$ )	C <sub>max</sub> ( $\mu\text{g}/\text{mL}$ )	C <sub><math>\tau</math></sub> or C <sub>0</sub> ( $\mu\text{g}/\text{mL}$ )	T <sub>max</sub> <sup>a</sup> (h)
LAI116482 (LATTE)	10 mg tab (n=14)	Induction Phase +2 NRTIs	45.7 [38.2, 54.6] (32)	2.77 [2.3, 3.3] (33)	1.35 <sup>b</sup> [1.2, 1.5] (45)	1.0 (0.9 – 8.0)
		Maintenance Phase +RPV 25 mg	---	---	1.34 <sup>c</sup> [1.1, 1.6] (58)	---
	30 mg tab (n=12)	Induction Phase +2 NRTIs	134 [110, 163] (32)	7.49 [6.3, 8.9] (28)	4.20 <sup>d</sup> [3.8, 4.7] (40)	2.0 (1.0 – 8.0)
		Maintenance Phase +RPV 25 mg	---	---	3.93 <sup>e</sup> [3.5, 4.4] (44)	---
	60 mg tab (2x30 mg) (n=9)	Induction Phase +2 NRTIs	195 [138, 277] (48)	11.5 [8.8, 15.0] (36)	7.93 <sup>f</sup> [7.2, 8.8] (39)	2.0 (1.0 – 8.0)
		Maintenance Phase +RPV 25 mg	---	---	8.22 <sup>g</sup> [7.4, 9.1] (37)	---
200056 LATTE-2 Day 1, predose	30 mg tab (n=246)	Induction Phase +2NRTIs	---	---	4.22 [4.0, 4.4] (43)]	---

a. median (range)

b. n=57

c. n=50

d. n=53

e. n=51

f. n=55

g. n=49

**4.5.2. Long Acting Injectable for Maintenance Phase**

The safety and efficacy of a 2-drug regimen with CAB and RPV for maintenance of virologic suppression was established in LATTE, as detailed in Section 4.5.1, and informed the Phase 2b study (LATTE-2) with CAB LA and RPV LA. Study 200056 (LATTE-2) is an ongoing, Phase 2b dose-ranging study evaluating the long-term efficacy and safety of a two-drug, two-class combination of CAB LA + RPV LA given every 4 weeks (Q4W) or every 8 weeks (Q8W), as compared to an oral three-drug regimen, for

maintenance of virologic suppression in HIV-infected, treatment-naïve adults. The first phase of the LATTE-2 study was a 20-week Induction Phase (16 weeks of oral CAB + 2 NRTIs, 4 weeks of CAB + 2 NRTIs + oral RPV). Participants who were eligible to continue into the Maintenance Phase were then randomized (2:2:1) to receive IM injections of CAB LA every 4 weeks (800 mg Day 1 then 400 mg Q4W) or every 8 weeks (800 mg Day 1, 600 mg Week 4, 600 mg Week 8, then 600 mg Q8W) in combination with IM RPV LA every 4 weeks (600 mg Day 1 then 600 mg Q4W) or every 8 weeks (900 mg Day 1, 900 mg Week 8, then 900 mg Q8W), respectively, or to continue on their triple ART regimen.

The Q4W dosing strategy was selected for further investigation in Phase 3 based on observed efficacy, safety, and tolerability at Week 48. Both Q4W and Q8W regimens were continued throughout the Maintenance Phase as planned, and Week 96 results (Table 4) were supportive of further evaluation of the Q8W regimen in the present study. Moreover, LATTE-2 was amended to permit subjects to remain on their randomized LA regimen (either Q4W or Q8W) during the Extension Phase (post Week 96), and those subjects randomized to the oral comparator arm were allowed transition to either LA regimen at Week 96. Forty-four subjects were transitioned from the oral comparator arm to LA treatments in the Extension Phase; 34 (77%) opted for the Q8W regimen and 10 (23%) for the Q4W regimen. Initial LA injections were administered at Week 100 following a 4-week oral lead-in where 2 NRTIs were discontinued and RPV 25 mg once daily was added to CAB 30 mg once daily.

**Table 4 Summary of Study Outcomes (<50 copies/mL) at Weeks 48 and 96 – Snapshot (MSDF) Analysis (ITT-ME Population) in LATTE-2**

Endpoint (Week)	Outcome	Q8W IM N=115 n (%)	Q4W IM N=115 n (%)	CAB 30 mg+ ABC/3TC N=56 n (%)	Subtotal IM N=230 n (%)
W48	Virologic Success, n (%)	106 (92)	105 (91)	50 (89)	211 (92)
	Virologic Failure, n (%)	8 (7)	1 (<1)	1 (2)	9 (4)
W96	Virologic Success, n (%)	108 (94)	100 (87)	47 (84)	208 (90)
	Virologic Failure, n (%)	5 (4)	0	1 (2)	5 (2)

Observed pharmacokinetic data for both CAB LA regimens in LATTE-2 are presented in Figure 3 and summarized in Table 5.



Figure 3 Observed Mean (SD) Concentration-Time Data following CAB LA

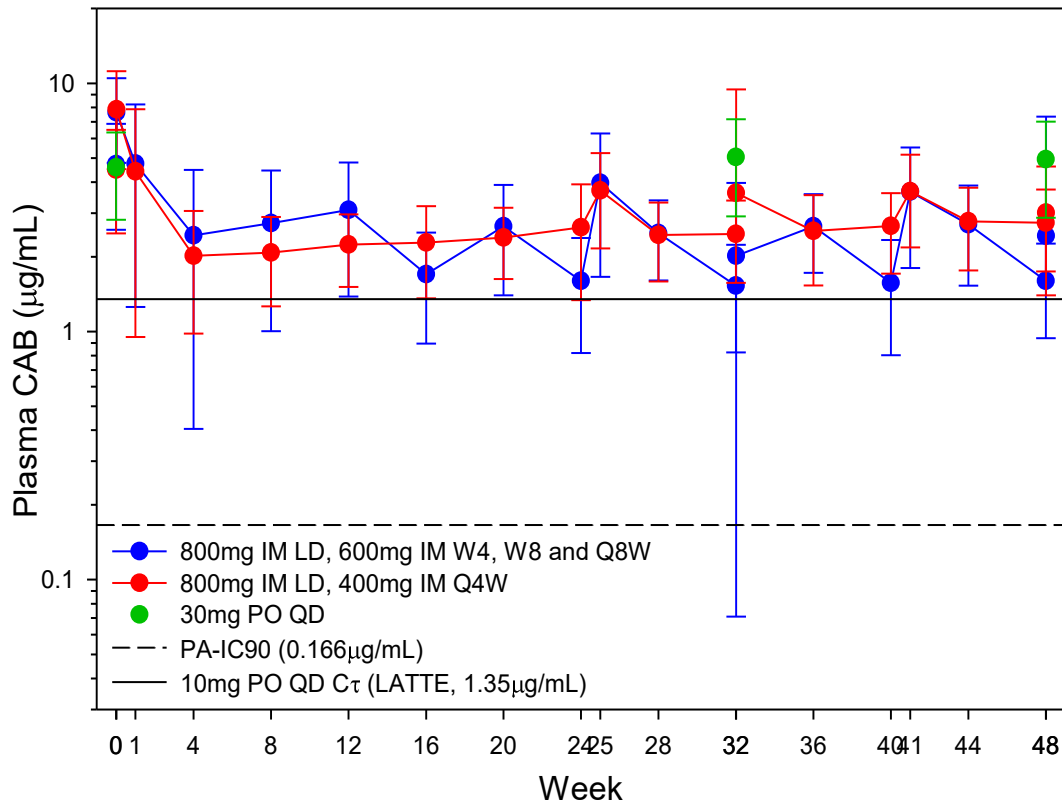

Both predose and 2h post injection concentrations are shown at Time Zero, Week 32, and Week 48.



**Table 5 Summary of CAB PK Parameters Following Repeat Dose Administration of CAB LA to Healthy and HIV-infected Subjects**

Population	Study	CAB LA Regimen	Dosing Interval	Plasma CAB PK Parameter (Geometric mean [95%CI] (CVb%))			
				AUC(0- $\tau$ ) ( $\mu\text{g}\cdot\text{h}/\text{mL}$ )	C <sub>max</sub> ( $\mu\text{g}/\text{mL}$ )	C <sub><math>\tau</math></sub> ( $\mu\text{g}/\text{mL}$ )	T <sub>max</sub> <sup>a</sup> (day post last dose)
Healthy Subjects	LAI115428	800 mg IM/ 400 mg IM Q4W (n=10)	D1-W4	1252 [836, 1873] (61)	2.74 [1.72, 4.35] (72)	1.78 [1.35, 2.36] (41)	6 (6 – 28)
			W4-W8	2010 [1619, 2494] (31)	3.79 [2.89, 4.99] (40)	2.60 [2.20, 3.07] (24)	6 (2 – 28)
			W8-W12	2182 [1798, 2647] (28)	4.03 [3.05, 5.30] (40)	2.69 [2.21, 3.27] (28)	6 (2 – 28)
			W12-W16	2473 [2063, 2965] (26)	4.41 [3.55, 5.48] (31)	3.27 [2.71, 3.94] (27)	6 (2 – 13)
HIV Infected Subjects	200056 LATTE2	800 mg IM/ 400 mg IM Q4W (n=115)	W24-W28 (n=97)	1858 <sup>b</sup> [1719, 2007] (37)	3.50 [3.2, 3.8] (39)	2.35 <sup>c</sup> [2.2, 2.5] (32)	6.9 (0 – 29)
			W40-W44 (n=95)	2017 <sup>d</sup> [1847, 2203] (41)	3.50 <sup>e</sup> [3.3, 3.8] (37)	2.56 <sup>f</sup> [2.4, 2.7] (32)	6.9 (0 – 28)
		800 mg IM/ 600 mg IM Q8W (n=115)	W24-W32 (n=98)	3037 <sup>g</sup> [2786, 3310] (42)	3.55 [3.2, 3.9] (56)	1.43 <sup>h</sup> [1.3, 1.6] (54)	6.9 (0 – 59)
			W40-W48 (n=104)	3027 <sup>i</sup> [2762, 3322] (47)	3.33 [3.1, 3.6] (47)	1.49 [1.4, 1.6] (42)	7.0 (0 – 57)

- a. median (range)  
b. n=84  
c. n=108  
d. n=80  
e. n=98  
f. n=86  
g. n=100  
h. n=93  
i. n=112

The CAB LA population PK model was updated to include data from CAB LA pre-exposure prophylaxis (PrEP) Study 201120 (ÉCLAIR; GlaxoSmithKline Document Number [2016N269422\\_00](#)) and Study 200056 (LATTE-2), increasing the original model from 93 subjects to 416 subjects receiving CAB LA single or repeat IM injections. Modeling and simulation was used to enable simplification and alignment of loading dose strategy used in LATTE-2 for both Q4W and Q8W CAB LA and RPV LA dosing regimens, resulting in selection of optimized Q4W and Q8W LA dosing regimens for use in Phase 3 studies (Q4W) and the present study (Q4W and Q8W) as discussed in Section [4.5.2.1](#) and Section [4.5.2.2](#).

**4.5.2.1. CAB LA Q8W**

The CAB LA 600mg Q8W regimen is predicted to achieve concentrations above 1.35 µg/mL, the geometric mean C<sub>τ</sub> following oral CAB 10 mg once daily which was shown to be efficacious in the LATTE study. The lower bound of the 90% prediction interval is approximately 0.166 µg/mL, indicating that 95% of subjects on this regimen should remain above the PA-IC<sub>90</sub> throughout dosing (Figure 4). The CAB LA Q8W regimen consists of identical 600 mg doses administered at Day 1, Week 4, and Q8W thereafter.

**Figure 4 Simulated\* Median (90% Prediction Interval [PI]) CAB Plasma Concentrations versus Time for the Optimized CAB LA Q8W Regimen (600 mg IM Day 1, Week 4, Q8W Thereafter)^**

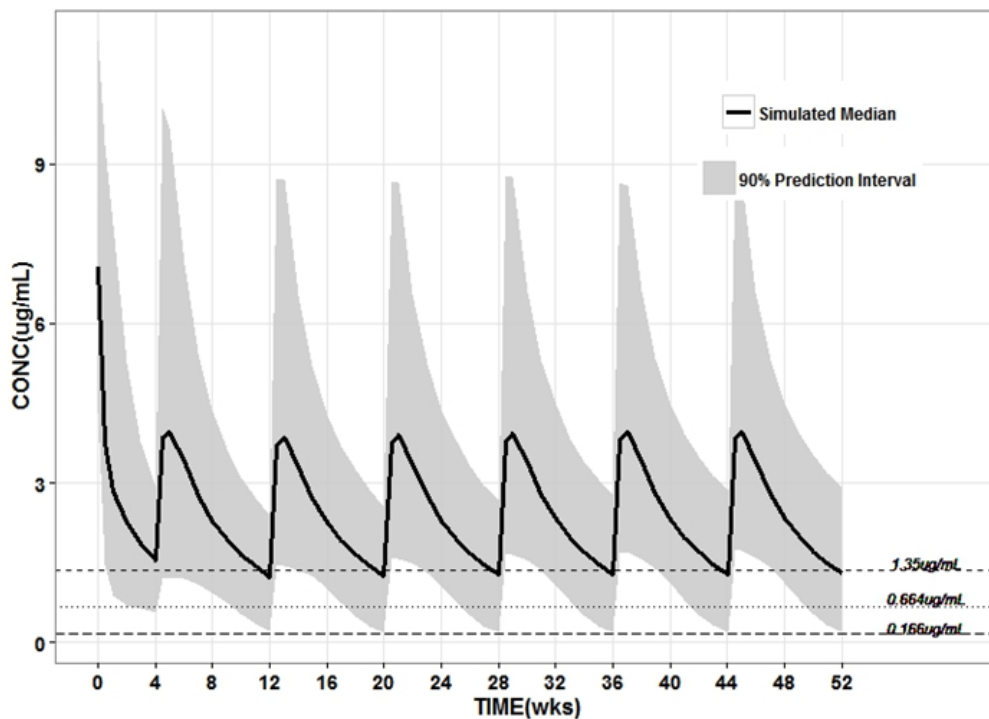

\*Note: current simulations based on interim plasma concentration dataset

^Study Time and Events include a 4-week oral lead in for subjects transitioning to Q8W from oral SOC. Therefore, Day 1 (time zero) = date of first injections in 207966

**4.5.2.1.1. CAB PK Profile Following Transition to Q8W Regimen**

There are two ways in which study participants may transition to the Q8W regimen, either directly from oral SOC or directly from Q4W dosing from ATLAS. Figure 4 shows the predicted plasma CAB PK profile for SOC participants directly transitioning to Q8W dosing following completion of the oral lead-in phase. The majority of participants receiving Q4W injections will have received injections for more than 1 year and will have achieved steady-state CAB concentrations within ATLAS well before transitioning to Q8W dosing in ATLAS-2M. Figure 5 shows the predicted plasma CAB PK profile for

participants directly transitioning to Q8W dosing from Q4W dosing who have achieved steady-state plasma CAB concentrations. Other participants, however, may have only received a short course of Q4W injections in ATLAS and will have not yet achieved steady-state plasma CAB concentrations prior to transitioning to Q8W dosing. Figure 6 shows the predicted plasma CAB PK profile for participants directly transitioning to Q8W dosing from a short course of Q4W dosing who have not achieved steady-state plasma CAB concentrations.

**Figure 5 Predicted Median (90% PI) CAB Profile following Steady State CAB LA Q4W Administration in ATLAS prior to Transitioning to Q8W on Day 1 of ATLAS-2M assuming 20% of participants are female.**

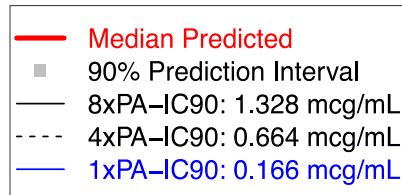
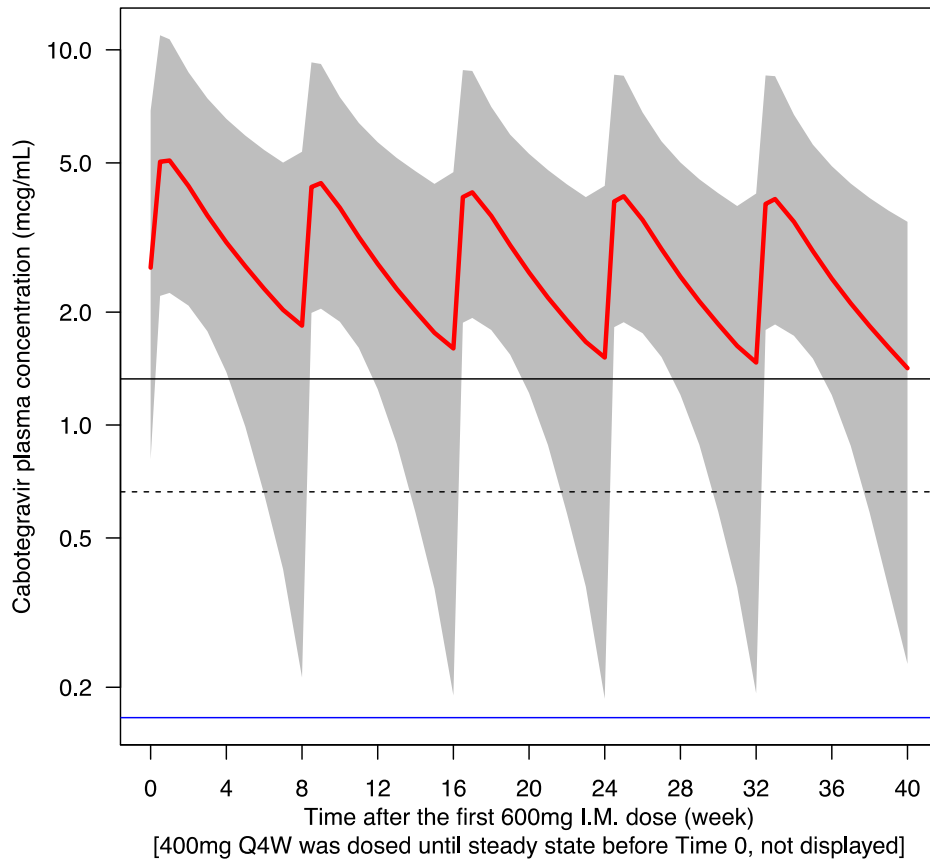

**Figure 6 Predicted Median (90% PI) CAB Profile following a Short Course of CAB LA Q4W Administration in ATLAS prior to Transitioning to Q8W on Day 1 of ATLAS-2M assuming 20% of participants are female.**

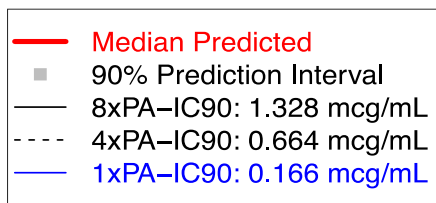
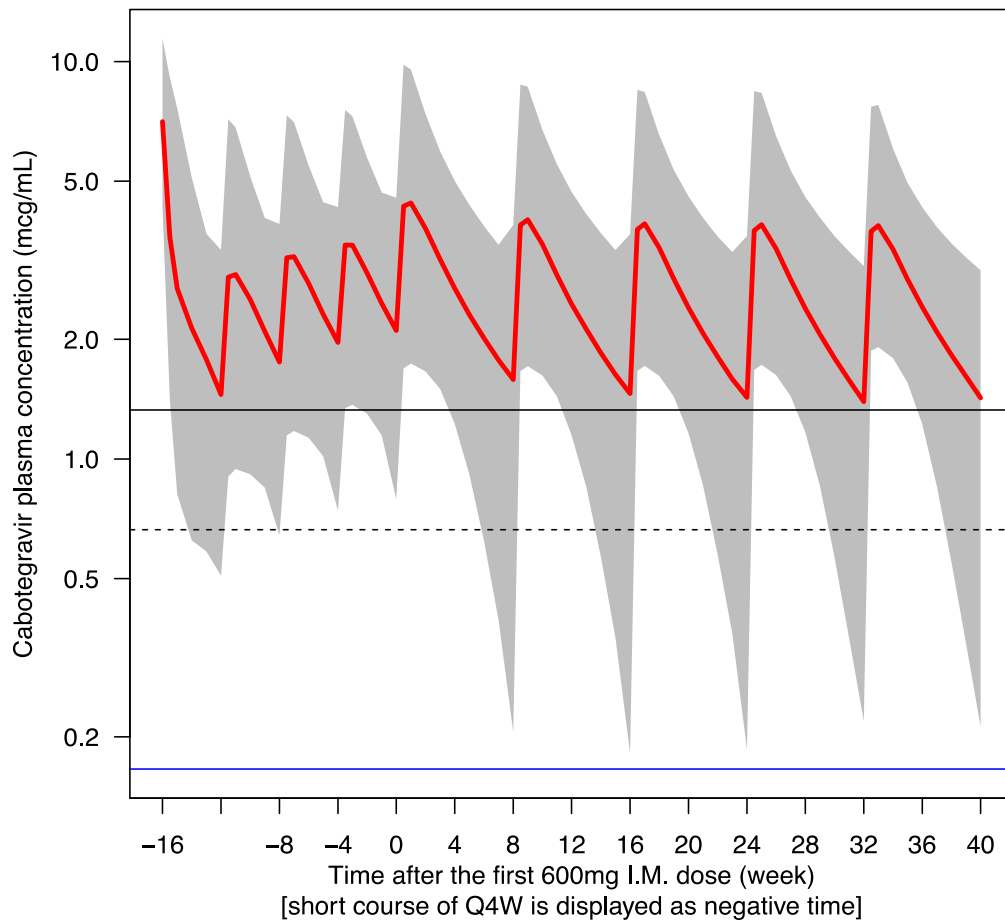
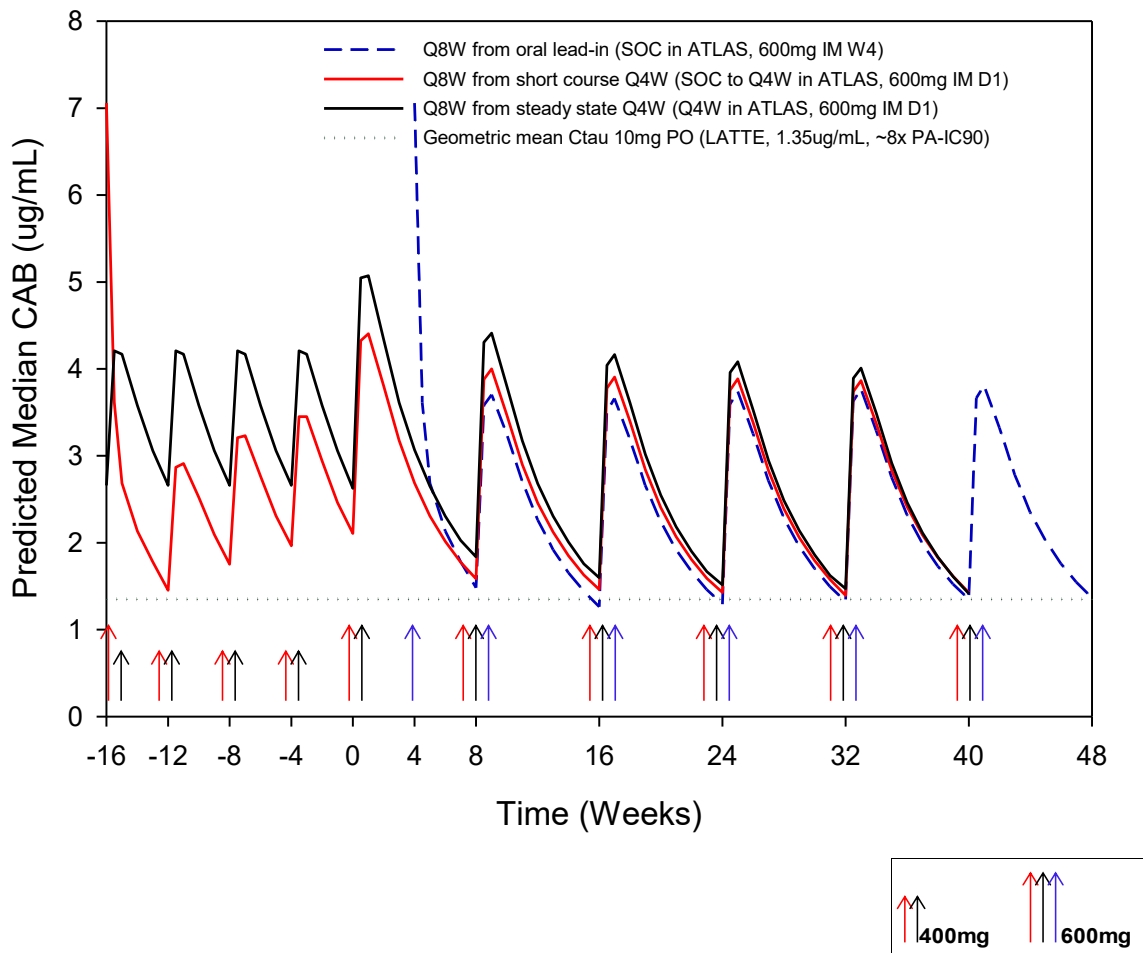

Figure 7 simultaneously shows the median predicted plasma CAB PK profile following transition to Q8W dosing from oral SOC, a short course of Q4W, or long-term Q4W dosing. Regardless of route of transition (oral or IM) or prior length of IM dosing (short course or steady-state), plasma CAB concentrations are predicted to be safe and efficacious during the transition period and all participants are expected to achieve comparable target concentrations at Week 48. In addition, Figure 7 demonstrates that participants transitioning from Q4W dosing (regardless of short course or long-term Q4W dosing), do not require an intermediate dose at Week 4 as plasma CAB concentrations are above Q8W targets and thus can commence Q8W dosing starting from the first Q8W dose at Day 1.

**Figure 7 Predicted CAB Profiles for CAB LA Q8W after Transition from Oral**



A one-week delay in CAB LA dosing for the Q8W regimen at steady state is predicted to result in ~92% rather than 95% of subjects achieving trough concentrations above the PA-IC90, which is considered acceptable.

**4.5.2.2. CAB LA Q4W**

There are two ways in which study participants may transition to the Q4W regimen, either directly from oral SOC or directly from Q4W dosing from ATLAS. Figure 8 shows the predicted plasma CAB PK profile for SOC participants directly transitioning to Q4W dosing following completion of the oral lead-in phase. Former ATLAS participants receiving Q4W injections and randomized to the Q4W dosing arm of ATLAS-2M will continue receiving Q4W injections as scheduled.

The CAB LA 400 mg Q4W regimen is predicted to achieve trough concentrations above 4x PA-IC90 in 98% of participants at steady-state and 88% is predicted to achieve trough concentrations above the geometric mean trough following the 10 mg oral dose in LATTE of 1.35 µg/mL (8x PA-IC90). The lower bound of the PI remains approximately at or above 4x PA-IC90 throughout dosing (Figure 8). The CAB LA Q4W regimen

consists of a 600 mg loading dose on Day 1 followed by a 400 mg maintenance dose at Week 4 and Q4W thereafter.

**Figure 8 Simulated\* Median (90% Prediction Interval [PI]) CAB Plasma Concentrations versus Time for the Optimized CAB LA Q4W Regimen (600 mg IM Day 1, then 400 mg IM Q4W thereafter^)**

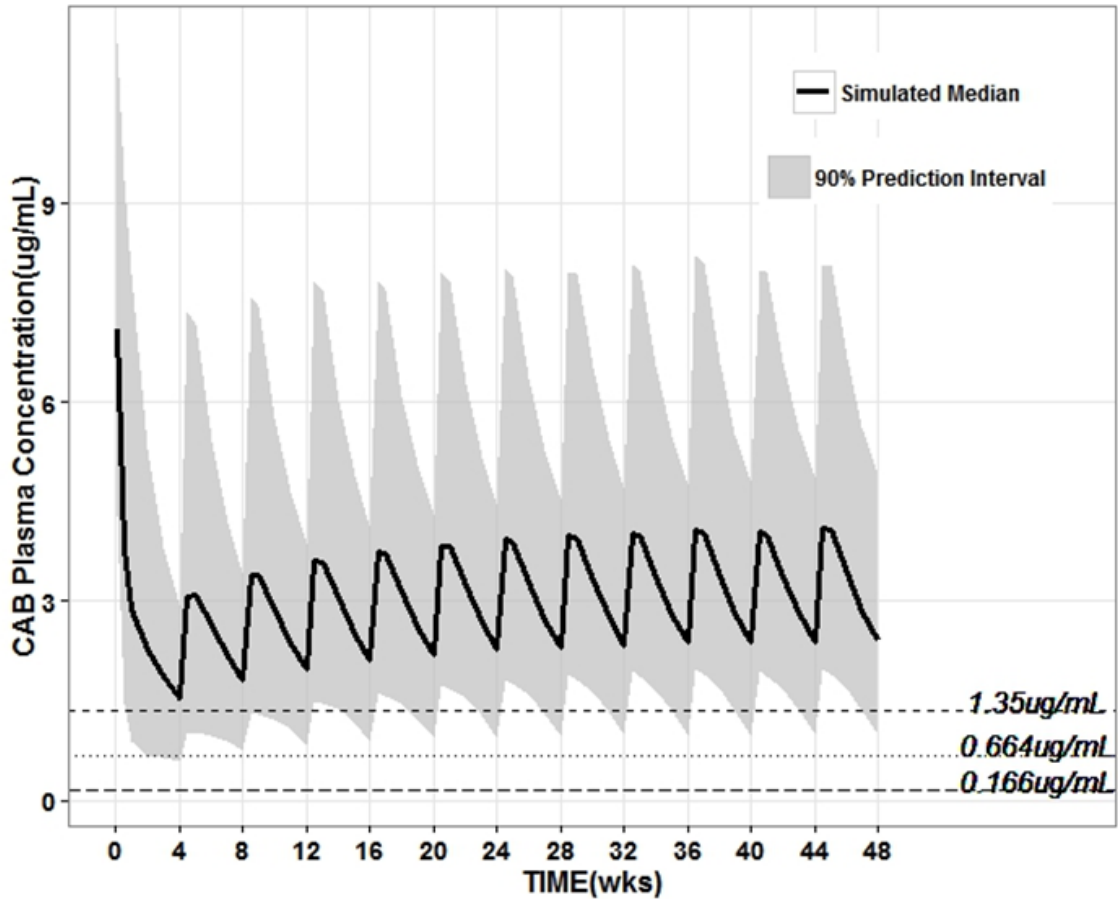

\* Note: current simulations based on interim plasma concentration dataset

^Study Time and Events include a 4-week oral lead in. Therefore, Day 1 (time zero) = date of first injections in 207966

Medium dashed line at 1.35  $\mu\text{g}/\text{mL}$  corresponds to the geometric mean Ctrough concentration following oral CAB 10 mg once daily (LATTE) and is equivalent to 8x PA-IC<sub>90</sub>

Dotted line at 0.664  $\mu\text{g}/\text{mL}$  corresponds to 4x PA-IC<sub>90</sub>

Long dashed line at 0.166  $\mu\text{g}/\text{mL}$  corresponds to the PA-IC<sub>90</sub>.

At steady state, a one-week delay in dosing of the Q4W regimen results in approximately 15% reduction in median CAB trough. With this delay, 95% are predicted to remain above 4x PA-IC<sub>90</sub>, and 79% are predicted to remain above the 10 mg oral trough concentrations. Therefore, a 1-week delay is the maximum allowed per the protocol.

**4.5.3. RPV LA**

Observed PK data for both RPV LA Q4W and Q8W regimens in LATTE-2 are presented in [Figure 9](#) and [Table 6](#). The RPV LA population PK model has been updated to include data from LATTE-2 and from Phase 1 studies in healthy volunteers.

**Figure 9 Observed Mean (SD) Plasma Concentration-Time Data following RPV LA Q8W and Q4W through Week 48 and Day 4 C<sub>tr</sub> following RPV**

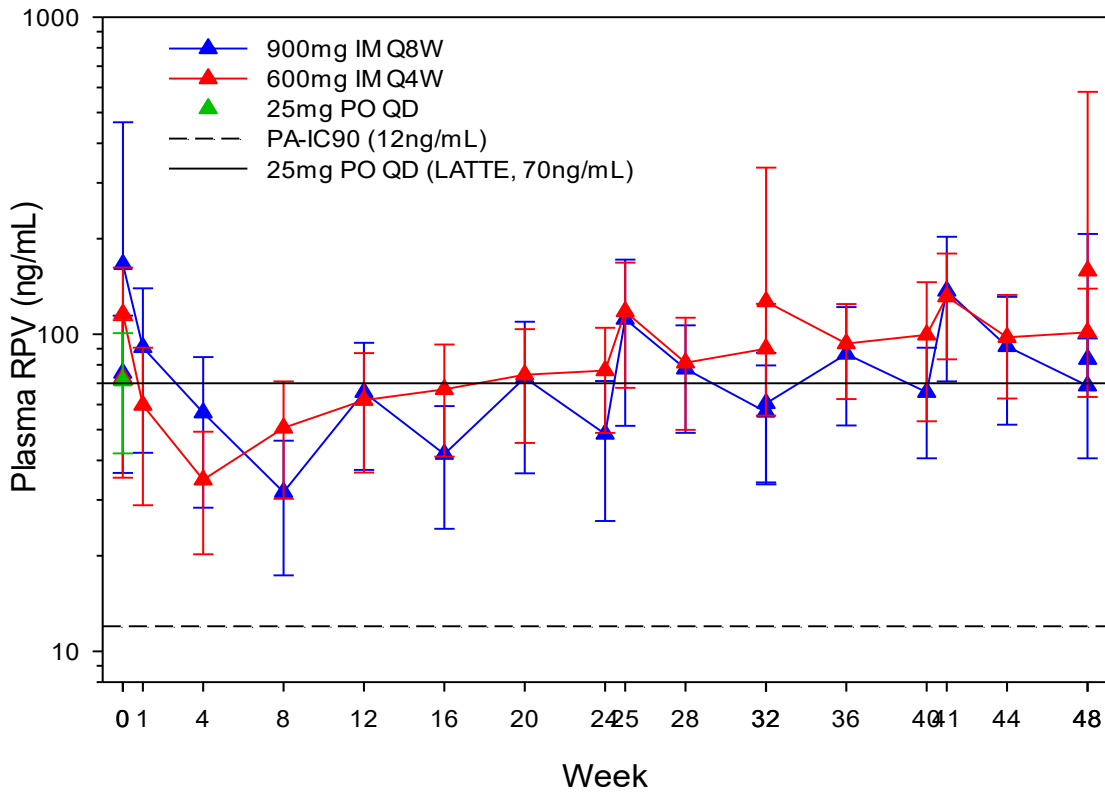

Both predose and 2 hr post injection concentrations are shown at Time Zero, Week 32, and Week 48.

**Table 6 Summary of RPV PK Parameters following Repeat Dose RPV LA Administration with CAB LA in Healthy and HIV-infected Subjects**

Study/ Population	RPV LA Regimen	Dosing Interval (from 1st RPV IM dose)	Plasma RPV PK Parameter (Geometric mean [95%CI] (CVb%))			
			AUC(0- $\tau$ ) ( $\mu\text{g}\cdot\text{h/mL}$ )	C <sub>max</sub> ( $\mu\text{g/mL}$ )	C $\tau$ ( $\mu\text{g/mL}$ )	T <sub>max</sub> <sup>a</sup> (day post last dose)
LAI115428/ Healthy Subjects	1200 mg IM/ 900 mg IM (+ CAB LA 200 mg IM) (n=9)	D1-W4	52762 [36468, 76335] (51)	109 [74.2, 159] (53)	61.6 [39.3, 96.6] (64)	6 (1.8 – 20)
		W4-W8	74420 [57323, 96615] (35)	168 [128, 222] (37)	79.1 [57.2, 109] (44)	6 (2 – 13)
	1200 mg IM/ 600 mg IM (+ CAB LA 400 mg IM) (n=10)	D1-W4	52703 [42917, 64721] (29)	108 [87.6, 133] (30)	64.0 [50.6, 80.9] (34)	6 (2 – 28)
		W4-W8	63656 [50186, 80741] (34)	126 [101, 158] (32)	78.9 [60.3, 103] (39)	9.5 (2 – 27)
200056 (LATTE2)/ HIV Infected Subjects	600 mg IM Q4W (n=115)	W24-W28 (n=96)	61309 <sup>b</sup> [56724, 66264] (37)	111 [103, 120] (40)	77.2 <sup>c</sup> [72, 83] (35)	6.0 (0 – 29)
		W40-W44 (n=94)	71106 <sup>d</sup> [65354, 77366] (39)	127 [118, 136] (36)	92.1 <sup>e</sup> [87, 98] (32)	6.0 (0 – 28)
	900 mg IM Q8W (n=115)	W24-W32 (n=97)	96196 <sup>f</sup> [87286, 106015] (48)	104 [95, 114] (47)	49.3 <sup>g</sup> [46, 53] (41)	7.0 (0 – 57)
		W40-W48 (n=104)	116160 <sup>h</sup> [108189, 124719] (35)	121 [111, 131] (42)	63.2 <sup>i</sup> [59, 68] (35)	6.0 (0 – 59)

- a. median (range)  
b. n=84  
c. n=104  
d. n=80  
e. n=102  
f. n=86  
g. n=101  
h. n=92  
i. n=100

#### 4.5.3.1. RPV LA Q8W

The RPV LA Q8W regimen for this study (ATLAS-2M) was selected based on safety and efficacy data from study 200056 (LATTE-2) and supported by modeling and simulation of pharmacokinetic data obtained following administration RPV LA administration in healthy subjects (Phase 1 studies C158, and LAI115428 [GlaxoSmithKline Document Number [2011N112455\\_03](#)]) and in HIV-infected subjects (Phase 2 study LATTE-2), the majority of the data coming from 200056 (LATTE-2).



The RPV LA 900 mg Q8W regimen is predicted to achieve median (90% PI) steady-state  $C_{\tau}$  of 54 ng/mL (23 – 112 ng/mL) (Figure 10). With this regimen, 100% of subjects remain above the RPV PA-IC<sub>90</sub> during the whole dose interval at steady-state. These data are similar to the observed Week 32 median steady-state  $C_{\tau}$  in LATTE-2 for Q8W which was also 54 ng/mL and the mean  $C_{\tau}$  was 58 ng/mL. The RPV LA Q8W regimen consists of identical 900 mg doses administered at Day 1, Week 4, and Q8W thereafter. With the second RPV LA dose administered 4 weeks after the first dose, the anticipated median RPV  $C_{\tau}$  at Week 4 (prior to second injection) is 40 ng/mL (versus 30 ng/mL observed prior to second injection at Week 8 in LATTE-2, where the RPV LA dose at Week 4 was not included), with >92% of subjects above the RPV PA-IC<sub>90</sub> of 12 ng/mL.

**Figure 10 Simulated\* Median (90% PI) RPV Plasma Concentrations versus Time Profile for the Optimized RPV LA Q8W regimen (900 mg IM Day**

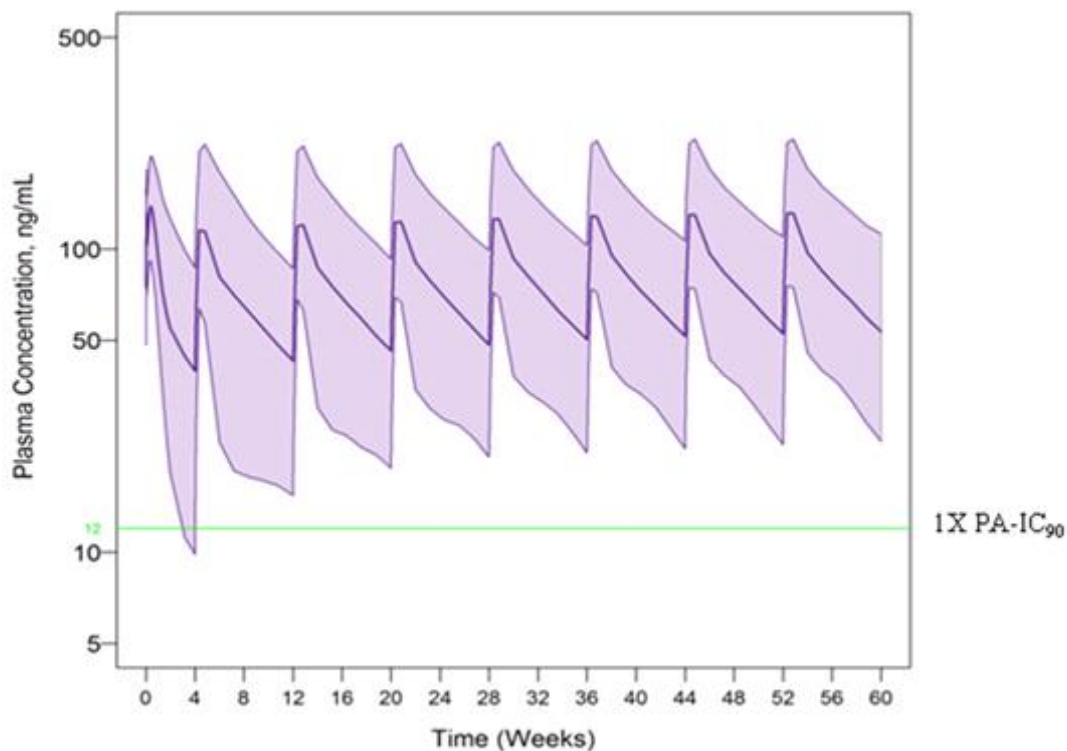

\* Note: current simulations based on interim plasma concentration dataset

^Study Time and Events include a 4 week oral lead in for subjects transitioning to Q8W from oral SOC. Therefore, Day 1 = date of first injections for Study 207966

#### 4.5.3.1.1. RPV PK Profile Following Transition to Q8W Regimen

As previously described, there are two ways in which study participants may transition to the Q8W regimen, either directly from oral SOC or directly from Q4W dosing from ATLAS. Figure 10 shows the predicted plasma RPV PK profile for SOC participants directly transitioning to Q8W dosing following completion of the oral lead-in phase.

Participants may also transition to RPV LA Q8W in ATLAS-2M following RPV LA Q4W, treatment for a minimum of 52 weeks in ATLAS or following a shorter duration of RPV LA Q4W treatment following transition from oral SOC after Week 52 in ATLAS. [Figure 11](#) shows the predicted plasma RPV PK profile for participants directly transitioning to Q8W dosing from Q4W dosing who have achieved steady-state plasma RPV concentrations.

**Figure 11 Simulated Median (90% PI) RPV Profile following Steady State RPV LA Q4W Administration in ATLAS prior to Transitioning to Q8W on Day 1 of ATLAS-2M**

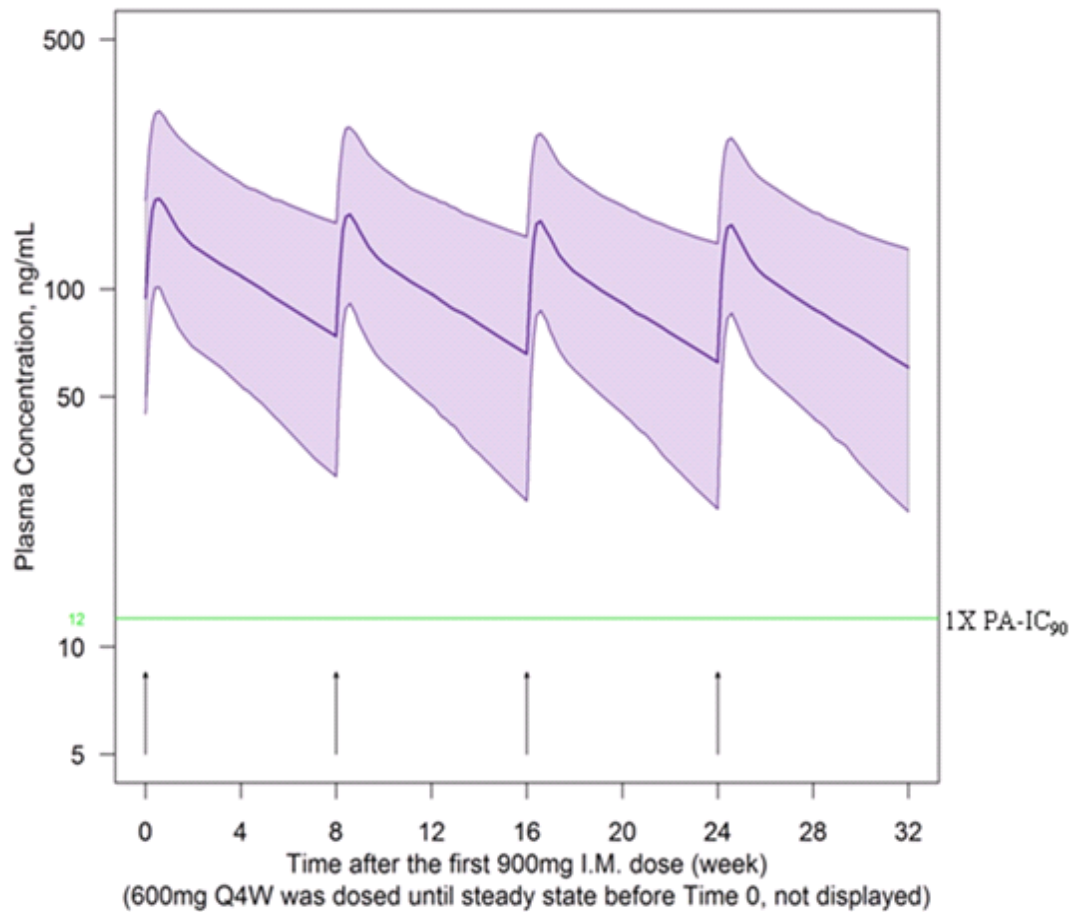

[Figure 12](#) shows the predicted median (90% PI) profile for subjects switching to RPV LA Q8W after having a short course of 4 RPV LA Q4W injections. In this setting, switching immediately to RPV LA 900 mg 8-weekly injections keeps the median  $C_{\tau}$  above 2x the RPV PA-IC<sub>90</sub> and 100% of subjects remain above the RPV PA-IC<sub>90</sub> during the whole dose interval. [Figure 13](#) shows that (until steady-state is reached), the median predicted  $C_{\tau}$  for those transitioning from Q4W to Q8W is higher than the predicted  $C_{\tau}$  for those transitioning from oral to Q8W, despite not having the extra RPV LA 900 mg IM injection 4 weeks after the first injection on the Q8W regimen. This therefore justifies

the simplified RPV LA dosing regimen (without injection at Week 4) for those subjects that are already on a Q4W regimen.

Therefore, regardless of the length of time that they are already on RPV LA Q4W treatment, such subjects transitioning to RPV LA Q8W will receive RPV LA 900 mg IM Q8W from Day 1 of ATLAS-2M.

**Figure 12 Simulated Median (90% PI) RPV Plasma Concentration versus Time Profile for Subjects Switching from a Short Course Q4W Regimen in ATLAS to a Q8W regimen (RPV LA on Day 1 and Q8W thereafter^)**

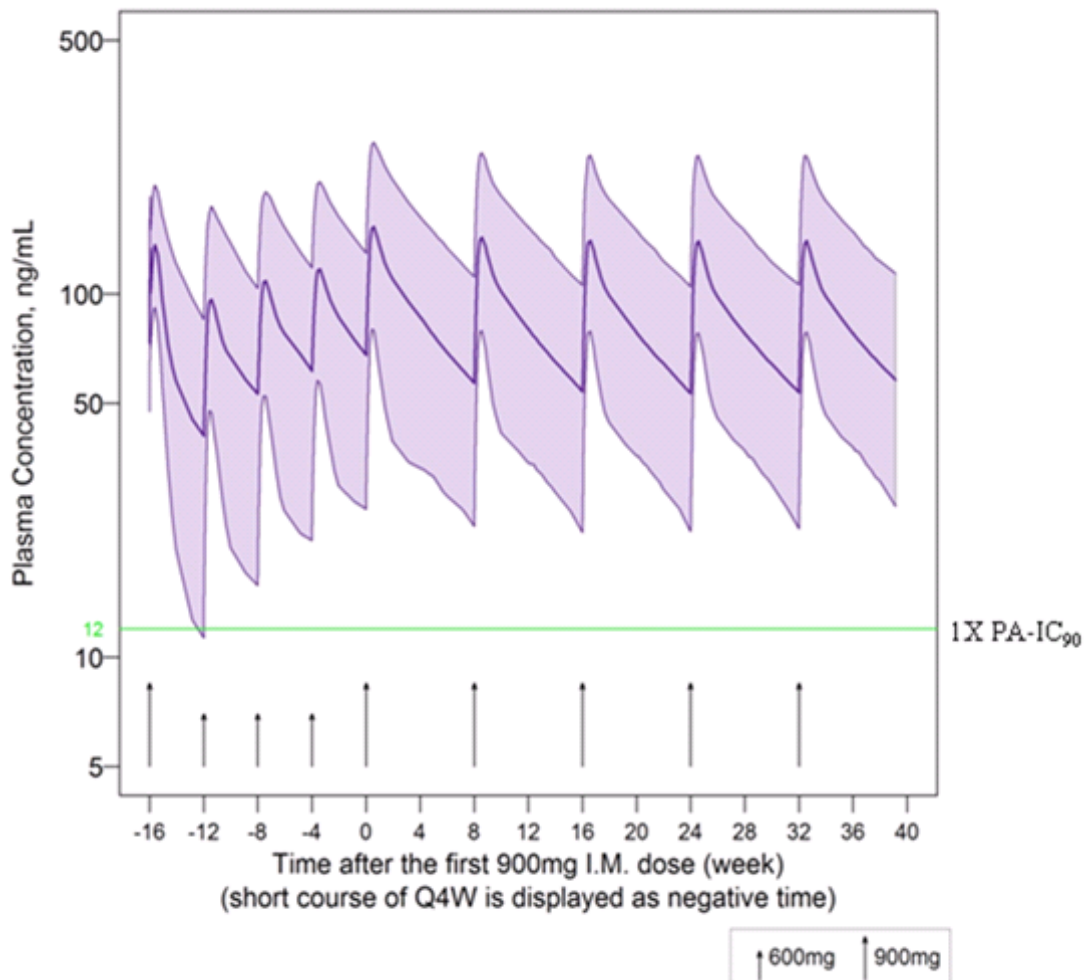

**Figure 13 Simulated Median RPV Plasma Concentration versus Time Profile for Subjects Switching Either from an Oral Regimen or from a Q4W Regimen to a Q8W regimen**

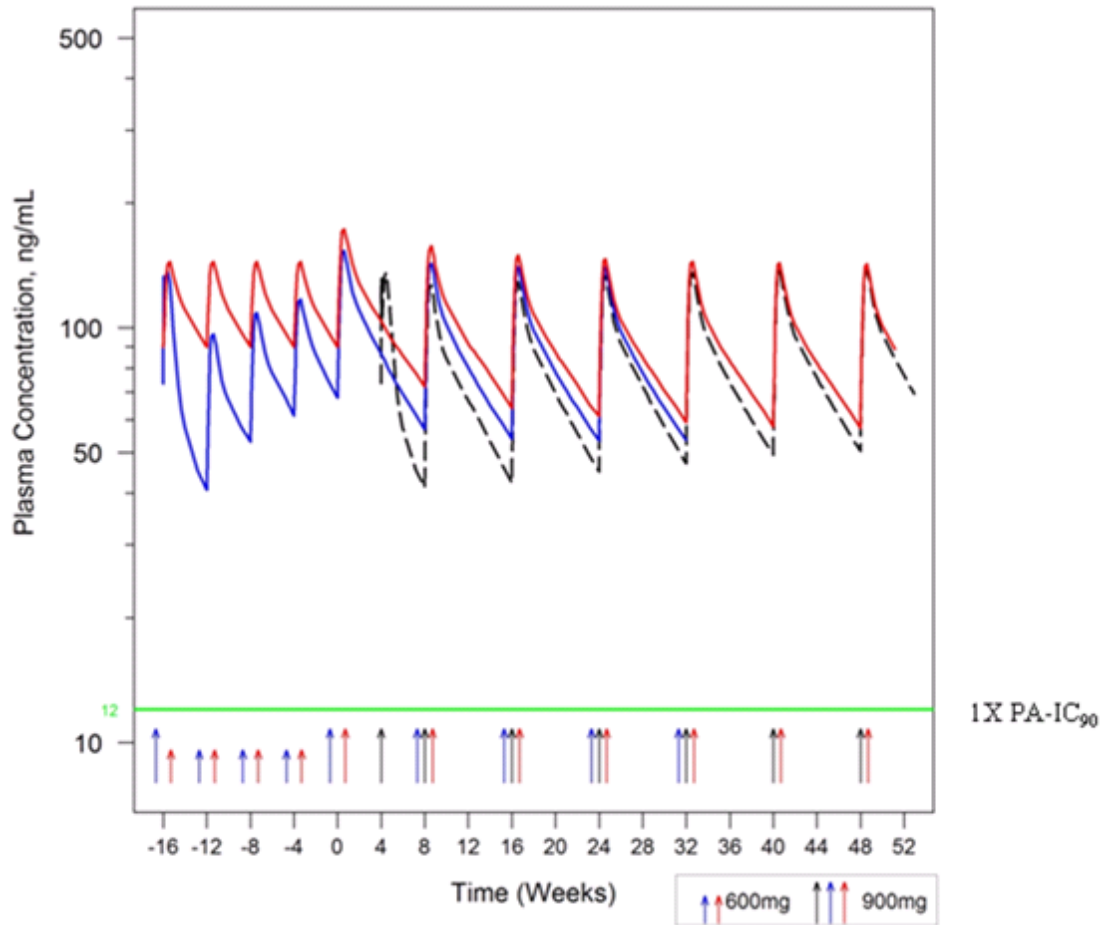

At steady-state, a one-week delay in dosing for the Q8W regimen is predicted to result in a median steady-state  $C_{\tau}$  that is approximately 11% lower (48 ng/mL) than for dosing that is administered on schedule, with >99% of subjects still remaining above the RPV PA-IC<sub>90</sub>. This supports allowance of some flexibility in the dosing regimen in ATLAS-2M, similar to what is currently practiced in the LATTE-2 study.

#### 4.5.3.2. RPV LA Q4W

The RPV LA Q4W regimen for ATLAS-2M was selected based on LATTE-2 safety and efficacy data as described above and supported by modeling and simulation of pharmacokinetic data as described above. The Q4W dose regimen consists of a RPV LA 900 mg dose on Day 1, and RPV LA 600 mg every 4 weeks thereafter. This regimen is also studied in the Phase 3 studies ATLAS and FLAIR.

There are two ways in which study participants may transition to the Q4W regimen, either directly from oral SOC or directly from Q4W dosing from ATLAS. [Figure 14](#) shows the predicted plasma RPV PK profile for SOC participants directly transitioning to

Q4W dosing following completion of the oral lead-in phase. Former ATLAS participants receiving Q4W injections and randomized to the Q4W dosing arm of ATLAS-2M will continue receiving Q4W injections as scheduled.

The predicted median (90% PI) steady-state  $C_{\tau}$  for the proposed regimen is 84 ng/mL (41 – 161 ng/mL, Figure 14). With this regimen, >99% of participants remain above the 5th percentile of steady state trough values following oral RPV 25 mg (corresponding to 2x the PA-IC90). With a loading dose of 900 mg RPV LA on Day 1, the anticipated median RPV  $C_{\tau}$  at Week 4 is 40 ng/mL, with >92% of participants above the RPV PA-IC90.

**Figure 14 Simulated\* Median (90% PI) RPV Plasma Concentrations versus Time Profile for the RPV LA Q4W regimen (900 mg IM Day 1, then 600 mg IM Q4W thereafter^)**

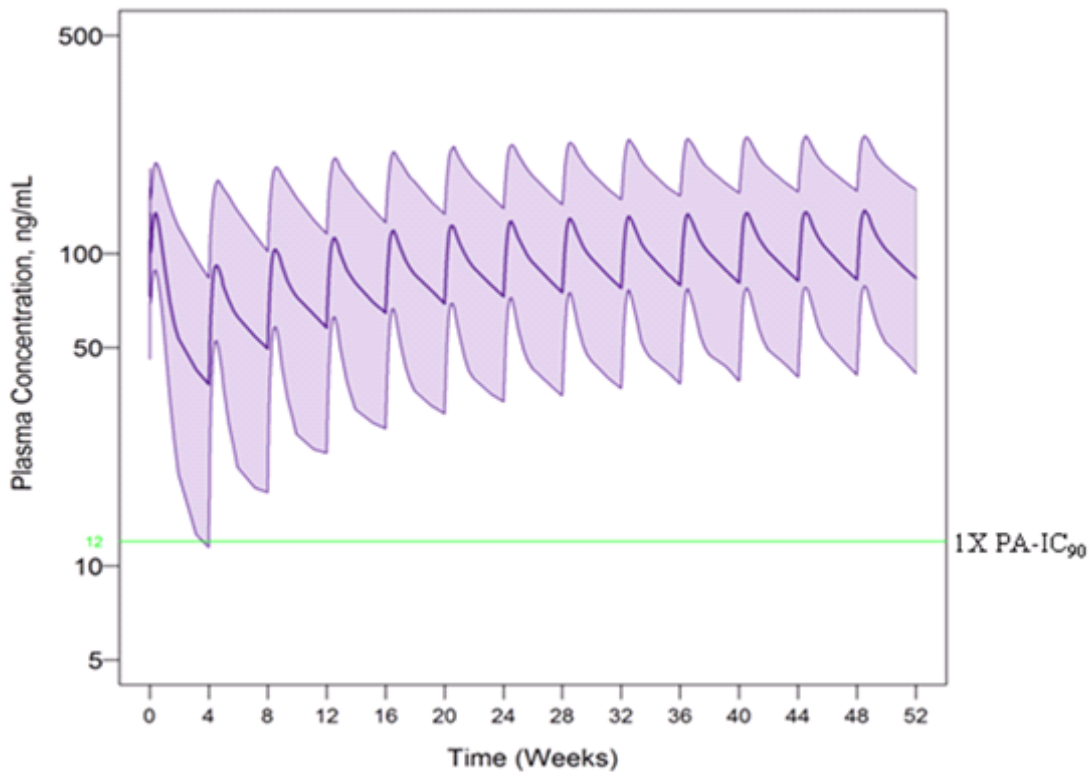

\* Note: current simulations based on interim plasma concentration dataset

^Study Time and Events include a 4-week oral lead in. Therefore, Day 1 = day of first injections for Study 207966

At steady-state, a one-week delay in dosing for the Q4W regimen is predicted to result in a median steady-state  $C_{\tau}$  that remains above the median trough for oral RPV 25 mg once daily. This supports allowance of some flexibility in the dosing regimen, as also practiced in LATTE-2 and the Phase 3 studies FLAIR and ATLAS.

## 5. SELECTION OF STUDY POPULATION AND WITHDRAWAL CRITERIA

Specific information regarding warnings, precautions, contraindications, adverse events, and other pertinent information on the investigational regimen or other study treatment that may impact participant eligibility is provided in the current Investigator's Brochures (IB) for CAB and RPV and Edurant product label.

Deviations from inclusion and exclusion criteria are not allowed because they can potentially jeopardize the scientific integrity of the study, regulatory acceptability or participant safety. Therefore, adherence to the criteria as specified in the protocol is essential.

### 5.1. Inclusion Criteria

A participant will be eligible for inclusion in this study only if all of the following criteria apply:

- Be able to understand and comply with protocol requirements, instructions, and restrictions;
- Understand the long term commitment to the study and be likely to complete the study as planned;
- Be considered appropriate candidates for participation in an investigative clinical trial with oral and intramuscularly injectable medications (e.g., no active substance use disorder, acute major organ disease, or planned long-term work assignments out of the country, etc.).

The following are study specific eligibility criteria unless stated otherwise. **In addition to these criteria, Investigators must exercise clinical discretion regarding selection of appropriate study participants, taking into consideration any local treatment practices or guidelines and good clinical practice (GCP). All participants must be considered appropriate candidates for antiretroviral therapy in accordance with local treatment guidelines.**

Laboratory results from the central laboratory services provided by this trial will be used to assess eligibility. In exceptional circumstances only, if a repeat lab is required because a central lab result cannot be generated, local labs can be reviewed and approved by the Medical Monitor for consideration of participant eligibility. A repeat central lab will be submitted concurrently or at the next planned visit.

Source documentation to verify entry criteria must be reviewed by the Principal Investigator or designee prior to randomization. Source documents from other medical facilities must be located/received during the 14-day screening phase (or up to 35 days) and under no circumstances may the participant be randomized in the absence of source documentation.

**All Participants eligible for enrolment in the study must meet all of the following criteria:**

AGE
1. Aged 18 years or older (or $\geq 19$ where required by local regulatory agencies), at the time of signing the informed consent.
SEX
<p>2. A female participant is eligible to participate if she is not pregnant (as confirmed by a negative serum human chorionic gonadotropin (hCG) test at screen and a negative urine hCG test at Randomization), not lactating, and at least one of the following conditions applies:</p> <p>a. <b>Non-reproductive</b> potential defined as:</p> <ul style="list-style-type: none"> <li>• <u>Pre-menopausal</u> females with one of the following: <ul style="list-style-type: none"> <li>• Documented tubal ligation</li> <li>• Documented hysteroscopic tubal occlusion procedure with follow-up confirmation of bilateral tubal occlusion</li> <li>• Hysterectomy</li> <li>• Documented Bilateral Oophorectomy</li> </ul> </li> <li>• <u>Postmenopausal</u> defined as 12 months of spontaneous amenorrhea [in questionable cases a blood sample with simultaneous follicle stimulating hormone (FSH) and estradiol levels consistent with menopause (refer to laboratory reference ranges for confirmatory levels)]. Females on hormone replacement therapy (HRT) and whose menopausal status is in doubt will be required to use one of the highly effective contraception methods if they wish to continue their HRT during the study. Otherwise, they must discontinue HRT to allow confirmation of post-menopausal status prior to study enrolment.</li> </ul> <p>b. <b>Reproductive potential</b> and agrees to follow one of the options listed in the Modified List of Highly Effective Methods for Avoiding Pregnancy in Females of Reproductive Potential (FRP) from 30 days prior to the first dose of study medication, throughout the study, for at least 30 days after discontinuation of all oral study medications, and for <u>at least 52 weeks</u> after discontinuation of CAB LA and RPV LA.</p>
The investigator is responsible for ensuring that participants understand how to properly use these methods of contraception.
INFORMED CONSENT
3. Capable of giving signed informed consent, which includes compliance with the requirements and restrictions listed in the consent form and in this protocol. Eligible participants or their legal guardians (and next of kin when locally required), must sign a written Informed Consent Form before any protocol-specified assessments are conducted. Enrolment of participants who are unable to

<p>provide direct informed consent is optional and will be based on local legal/regulatory requirements and site feasibility to conduct protocol procedures.</p>
<p>OTHER</p>
<p>4. Participants enrolled in France must be affiliated to, or a beneficiary of, a social security category.</p>
<p><b>Participants receiving oral standard of care (SOC) treatment for HIV-1 (not participating in ATLAS Trial)</b></p>
<p>5. Must be on uninterrupted current regimen (either the initial or second ARV regimen) for at least 6 months prior to Screening. Any prior switch, defined as a change of a single drug or multiple drugs simultaneously, must have occurred due to tolerability/safety, access to medications, or convenience/simplification, and must NOT have been done for treatment failure (HIV-1 RNA <math>\geq</math>400 c/mL).</p> <p>Acceptable stable (initial or second) ARV regimens prior to Screening include 2 NRTIs plus:</p> <ul style="list-style-type: none"> <li>• INI (either the initial or second cART regimen)</li> <li>• NNRTI (either the initial or second cART regimen)</li> <li>• Boosted PI (or atazanavir [ATV] unboosted) (must be either the initial cART regimen or one historical within class switch is permitted due to safety/tolerability)</li> </ul> <p>The addition, removal, or switch of a drug(s) that has been used to treat HIV based on antiretroviral properties of the drug constitutes a change in ART with the following limited exceptions:</p> <ul style="list-style-type: none"> <li>• Historical changes in formulations of ART drugs or booster drugs <u>will not</u> constitute a change in ART regimen if the data support similar exposures and efficacy, and the change must have been at least 3 months prior to Screening.</li> <li>• Historical perinatal use of an NRTI when given in addition to an ongoing HAART will not be considered a change in ART regimen.</li> <li>• A change in dosing scheme of the same drug from twice daily to once daily <u>will not</u> be considered a change in ART regimen if data support similar exposures and efficacy.</li> </ul> <p>6. Documented evidence of at least two plasma HIV-1 RNA measurements &lt;50 c/mL in the 12 months prior to Screening: one within the 6 to 12-month window, and one within 6 months prior to Screening;</p> <p>7. Plasma HIV-1 RNA &lt;50 c/mL at Screening;</p>
<p><b>Participants transitioning from 201585 (ATLAS)</b></p>
<p>8. Must have been on CAB LA 400 mg + RPV LA 600 mg Q4W or “Current ART”</p>



regimen through at minimum Week 52 of the ATLAS study as per ATLAS protocol dosing requirements and until Day 1 of the ATLAS-2M study. Any disruptions in dosing during ATLAS must be discussed with the Medical Monitor for a final determination of eligibility.

9. Plasma HIV-1 RNA <50 c/mL at Screening

**All participants** participating in the study should be counseled on safer sexual practices including the use and benefit/risk of effective barrier methods (e.g., male condom) and on the risk of HIV transmission to an uninfected partner.

**5.2. Exclusion Criteria**

Deviations from exclusion criteria are not allowed because they can potentially jeopardize the scientific integrity of the study, regulatory acceptability, or participant safety. Therefore, adherence to the criteria as specified in the protocol is essential. A participant will not be eligible for inclusion in this study if any of the following criteria apply:

<b>Exclusionary Criteria prior to Screening or Day 1 for patients not transitioning from 201585 (ATLAS)</b>
<ol style="list-style-type: none"> <li>1. Within 6 months prior to Screening, any plasma HIV-1 RNA measurement <math>\geq 50</math> c/mL</li> <li>2. Within the 6 to 12-month window prior to Screening, any plasma HIV-1 RNA measurement <math>&gt; 200</math> c/mL, or 2 or more plasma HIV-1 RNA measurements <math>\geq 50</math> c/mL</li> <li>3. Any drug holiday during the window between initiating first HIV ART and 6 months prior to Screening, except for brief periods (less than 1 month) where all ART was stopped due to tolerability and/or safety concerns</li> <li>4. Any switch to a second line regimen, defined as change of a single drug or multiple drugs simultaneously, due to virologic failure to therapy (defined as a confirmed plasma HIV-1 RNA measurement <math>\geq 200</math> c/mL after initial suppression to <math>&lt; 50</math> c/mL while on first line HIV therapy regimen)</li> <li>5. A history of use of any regimen consisting of only mono or dual HIV-1 therapy (even if only for peri-partum treatment).</li> <li>6. Participants who are currently participating in or anticipate to be selected for any other interventional study with the exception of the 201585 (ATLAS) study.</li> </ol>
<b>Participants transitioning from 201585 (ATLAS)</b>
<ol style="list-style-type: none"> <li>7. During participation in ATLAS, consecutive (2 or more sequential) plasma HIV-1</li> </ol>

RNA measurements  $\geq 50$  c/mL

8. During participation in ATLAS, any HIV-1 RNA measurement  $\geq 200$  c/mL
9. More than two total measurements of plasma HIV-1 RNA  $\geq 50$  c/mL during participation in the ATLAS trial will require direct approval by the ATLAS-2M Medical Monitor and Study virologist for study participation.

Exclusionary medical conditions- for all participants

10. Women who are pregnant, breastfeeding or plan to become pregnant or breastfeed during the study
11. Any evidence of a current Center for Disease Control and Prevention (CDC) Stage 3 disease [CDC, 2014], except cutaneous Kaposi's sarcoma not requiring systemic therapy, and CD4+ counts  $< 200$  cells/ $\mu$ L are not exclusionary.
12. Participants with moderate to severe hepatic impairment
13. Any pre-existing physical or mental condition (including substance use disorder) which, in the opinion of the Investigator, may interfere with the participant's ability to comply with the dosing schedule and/or protocol evaluations or which may compromise the safety of the participant
14. Participants determined by the Investigator to have a high risk of seizures, including participants with an unstable or poorly controlled seizure disorder. A participant with a prior history of seizure may be considered for enrolment if the Investigator believes the risk of seizure recurrence is low. All cases of prior seizure history should be discussed with the Medical Monitor prior to enrolment
15. All participants will be screened for syphilis. Participants with untreated secondary (late latent) or tertiary syphilis infection, defined as a positive RPR and a positive treponemal test without clear documentation of treatment, are excluded. Participants with a false positive RPR (with negative treponemal test) or serofast RPR result (persistence of a reactive nontreponemal syphilis test despite history of adequate therapy and no evidence of re-exposure) may enroll after consultation with the Medical Monitor. Participants with primary syphilis or early latent secondary syphilis (acquired within the preceding year) who have a positive RPR test and have not been treated may be treated during the screening period and if completion of antibiotic treatment occurs during the screening period, may be allowed entry after consultation with the Medical Monitor. If antibiotic treatment cannot be completed before the screening window ends, subjects may be rescreened once following completion of antibiotic therapy for primary or early latent secondary syphilis.
16. Participants who, in the investigator's judgment, pose a significant suicide risk. Participant's recent history of suicidal behavior and/or suicidal ideation should be considered when evaluating for suicide risk
17. The participant has a tattoo or other dermatological condition overlying the gluteus region which may interfere with interpretation of injection site reactions

18. Evidence of Hepatitis B virus (HBV) infection based on the results of testing at Screening for Hepatitis B surface antigen (HBsAg), Hepatitis B core antibody (anti-HBc), Hepatitis B surface antibody (anti-HBs) and HBV DNA as follows:
- a. •Participants positive for HBsAg are excluded;
  - b. •Participants negative for anti-HBs but positive for anti-HBc (negative HBsAg status) and positive for HBV DNA are excluded
- Note:* Participants positive for anti-HBc (negative HBsAg status) and positive for anti-HBs (past and/or current evidence) are immune to HBV and are not excluded.
19. Asymptomatic individuals with chronic hepatitis C virus (HCV) infection will not be excluded, however Investigators must carefully assess if therapy specific for HCV infection is required; participants who are anticipated to require HCV treatment within 12 months must be excluded. (HCV treatment on study may be permitted post Week 52, following consultation with the medical monitor)
20. Participants with HCV co-infection will be allowed entry into this study if:
- a. Liver enzymes meet entry criteria
  - b. HCV Disease has undergone appropriate work-up, and is not advanced, and will not require treatment prior to the Week 52 visit. Additional information (where available) on participants with HCV co-infection at screening should include results from any liver biopsy, Fibroscan, ultrasound, or other fibrosis evaluation, history of cirrhosis or other decompensated liver disease, prior treatment, and timing/plan for HCV treatment.
  - c. In the event that recent biopsy or imaging data is not available or inconclusive, the Fib-4 score will be used to verify eligibility
    - i. Fib-4 score >3.25 is exclusionary
    - ii. Fib-4 scores 1.45 – 3.25 requires Medical Monitor consultation

Fibrosis 4 Score Formula:

$$(Age \times AST) / (Platelets \times (\sqrt{ALT}))$$
21. Unstable liver disease (as defined by any of the following: presence of ascites, encephalopathy, coagulopathy, hypoalbuminemia, esophageal or gastric varices, or persistent jaundice or cirrhosis), known biliary abnormalities (with the exception of Gilbert's syndrome or asymptomatic gallstones or otherwise stable chronic liver disease per investigator assessment)
22. History of liver cirrhosis with or without hepatitis viral co-infection.
23. Ongoing or clinically relevant pancreatitis
24. Clinically significant cardiovascular disease, as defined by history/evidence of congestive heart failure, symptomatic arrhythmia, angina/ischemia, coronary artery bypass grafting (CABG) surgery or percutaneous transluminal coronary angioplasty (PTCA) or any clinically significant cardiac disease
25. Ongoing malignancy other than cutaneous Kaposi's sarcoma, basal cell

carcinoma, or resected, non-invasive cutaneous squamous cell carcinoma, or cervical intraepithelial neoplasia; other localized malignancies require agreement between the investigator and the Study medical monitor for inclusion of the participant prior to randomization

26. Any condition which, in the opinion of the Investigator, may interfere with the absorption, distribution, metabolism or excretion of the study drugs or render the participant unable to receive study medication
27. History or presence of allergy or intolerance to the study drugs or their components or drugs of their class. In addition, if heparin is used during PK sampling, participants with a history of sensitivity to heparin or heparin-induced thrombocytopenia must not be enrolled
28. Current or anticipated need for chronic anti-coagulation with the exception of the use of low dose acetylsalicylic acid ( $\leq 325$  mg) or hereditary coagulation and platelet disorders such as haemophilia or Von Willebrand Disease.

Exclusionary Laboratory Values or Clinical Assessments at Screening (a single repeat to determine eligibility is allowed)

29. Any evidence of primary resistance based on the presence of any major known INI or NNRTI resistance-associated mutation, except for K103N, (IAS, 2015) by any historical resistance test result.
 

Note: Prior genotypic resistance testing is not required but if available it must be provided to GSK, after screening and before randomization according to guidance in the SPM, to provide direct evidence of no pre-existing exclusionary resistance mutations. You must wait for the study virologists to confirm the lack of exclusionary resistance mutations, which will be provided before the screening window closes. Details regarding baseline or prior resistance data must be noted in the source documentation
30. Any verified Grade 4 laboratory abnormality. A single repeat test is allowed during the Screening phase to verify a result
31. Any acute laboratory abnormality at Screening, which, in the opinion of the investigator, would preclude the participant's participation in the study of an investigational compound
32. Participant has estimated creatine clearance  $< 50$  mL/min per  $1.73\text{m}^2$  via Chronic Kidney Disease-Epidemiology Collaboration (CKD-EPI) Method
33. Alanine aminotransferase (ALT)  $\geq 3 \times$  ULN

Concomitant Medications
<p>34. Exposure to an experimental drug (with the exception of those in the ATLAS study including CAB, CAB LA, and RPV LA) or experimental vaccine within either 30 days, 5 half-lives of the test agent, or twice the duration of the biological effect of the test agent, whichever is longer, prior to Day 1 of this study;</p> <p>35. Treatment with any of the following agents within 28 days of Screening:</p> <ul style="list-style-type: none"> <li>• radiation therapy;</li> <li>• cytotoxic chemotherapeutic agents;</li> <li>• tuberculosis therapy with the exception of isoniazid (isonicotinylhydrazid, INH);</li> <li>• anti-coagulation agents;</li> <li>• Immunomodulators that alter immune responses such as chronic systemic corticosteroids, interleukins, or interferons. Note: Participants using short-term (e.g. <math>\leq 21</math> days) systemic corticosteroid treatment; topical, inhaled and intranasal corticosteroids are eligible for enrolment.</li> </ul> <p>36. Treatment with an HIV-1 immunotherapeutic vaccine within 90 days of Screening</p> <p>37. Treatment with any agent, except recognized ART as allowed above, with documented activity against HIV-1 within 28 days of study Day 1. Treatment with acyclovir/valacyclovir is permitted.</p> <p>38. Use of medications which are associated with Torsade de Pointes. (See SPM for a list of relevant medications)</p> <p>39. Current or prior history of etravirine (ETR) use</p> <p>40. Current use of tipranavir/ritonavir or fosamprenavir/ritonavir</p> <p>41. Participants receiving any prohibited medication and who are unwilling or unable to switch to an alternate medication. Note: Any prohibited medications that decrease CAB or RPV concentrations should be discontinued for a minimum of four weeks or a minimum of three half-lives (whichever is longer) prior to the first dose and any other prohibited medications should be discontinued for a minimum of two weeks or a minimum of three half-lives (whichever is longer) prior to the first dose</p>

### 5.3. Additional Eligibility Criteria

To assess any potential impact on participant eligibility with regard to safety, the investigator must refer to the IB and supplements, approved product labels, and/or local prescribing information for detailed information regarding warnings, precautions, contraindications, AEs, drug interactions, and other significant data pertaining to the study drugs.

Notwithstanding these minimum inclusion and exclusion criteria, investigators must also follow country specific guidelines where they exist when making decisions about participants who are eligible for study participation.

Participation in other interventional studies or non-interventional studies that require any type of assessment outside the local standard of care practices is generally not permitted, however for eligible subjects in South Africa only, co-enrolment in the AIDS Clinical Trial Group ACTG interventional study (A5392) could be exceptionally permitted after review and approval by the Medical Monitor.

#### **5.4. Screening/Baseline/Run-in Failures**

Screen failures are defined as participants who consent to participate in the clinical trial but are never subsequently randomized. In order to ensure transparent reporting of screen failure participants, meet the Consolidated Standards of Reporting Trials (CONSORT) publishing requirements, and respond to queries from Regulatory authorities, a minimal set of screen failure information is required including Demography, Screen Failure details, Eligibility Criteria, and Serious Adverse Events.

A single repeat of a procedure / lab parameter is allowed to determine eligibility (unless otherwise specified).

Participants are allowed to re-screen for this study one time. This will require a new participant number.

#### **5.5. Withdrawal/Stopping Criteria**

Participants permanently discontinuing study treatments prior to the Week 100 visit are considered to be withdrawn from the study treatments.

Participants who enter the Extension Phase but permanently discontinue participation in the Extension Phase prior to the CAB LA + RPV LA marketed product is locally available are considered withdrawn from the study treatments but are not considered withdrawn from the study because they will enter the Long Term Follow-up Phase.

Participants who enter the Extension Phase but permanently discontinue participation in the Extension Phase when the CAB LA + RPV LA marketed product is locally available must enter the Long Term Follow-up Phase if they withdraw from the study due to safety-related reasons only.

The participant may withdraw consent and discontinue participation in this study at any time at his/her own request. The investigator may also, at his or her discretion, discontinue the participant from participating in this study at any time (e.g., safety, behavioral or administrative reasons). Participants may have a temporary interruption to their study treatment for management of toxicities. If a participant withdraws from the study, he/she may request destruction of any samples taken, and the investigator must document this in the site study records. Withdrawn participants will not be replaced.

All participants who discontinue prematurely from the study, irrespective of arm, will be asked for additional information to establish the reason for withdrawal.

Participants are not obligated to state the reason for withdrawal. However, the reasons for withdrawal, or failure to provide a reason, must be documented by the Investigator on the Completion/Withdrawal section of the electronic case report form (eCRF). Every effort should be made by the Investigator to follow-up participants who withdraw from the study.

An in-clinic withdrawal visit will also be used to assess participants with ongoing AEs, and serious adverse events (SAEs) related & not related to study drug and also any laboratory abnormalities that are considered to be AEs or potentially harmful to the participant. The withdrawal visit will be distinct from visits conducted during the LTFU Phase.

After completing withdrawal assessments, all participants who received one or more injections of CAB LA+ RPV LA will subsequently enter the LTFU Phase initiating with the Month 3 LTFU visit. When CAB LA + RPV LA marketed product is locally available, entering the LTFU phase is only required if the subject withdraws due to safety-related reasons.

**Withdrawal decision coincides with a planned clinic visit:**

- For any participant who withdraws prematurely from the Maintenance or Extension Phase during a planned in-clinic study visit, withdrawal assessments and procedures are to be performed (according to the Time and Events Table (Section 7.1) instead of the assessments for the active planned visit during which the withdrawal decision is made.

**Withdrawal decision occurs between planned clinic visits:**

- In the event that a decision to withdraw a participant occurs between clinic visits, participants will be instructed to return for an unscheduled withdrawal visit (within 4 weeks of the last Q4W LA injection or within 8 weeks of the last Q8W LA injection received) during which withdrawal assessments according to the Time and Events Table (Section 7.1) will be completed. For participants who received one or more injections of CAB LA+ RPV LA **withdrawal assessments must occur prior to initiation of the next ART regimen.**

If withdrawal coincides with the active planned Week 52, Week 100, or Week 156 (Q4W arm) visits, HIV-1 RNA will only be assessed if the last HIV-RNA measurement from Week 48, Week 96, or Week 152 was  $\geq 50$  copies per mL (i.e. retest for viral load blip). This will ensure that only the Week 48, Week 96, and Week 152 viral load assessments or required retest will be counted towards the primary and secondary efficacy endpoint windows.

The in-clinic visit will be recorded as an unscheduled withdrawal visit with the following exception. A withdrawal visit and assessments coinciding with the planned Week 100 visit will be recorded as the Week 100 visit such that the participant can be considered a completer, consistent with the definition of study completer in Section 5.6.

**Participants may be prematurely discontinued from the study treatment for any of the following reasons:**

- Adverse event / Serious adverse event
- Protocol deviation
- Intolerability of injections
- Participant lost to follow-up
- Participant or Investigator non-compliance;
- Termination of the study by the Sponsor
- At the request of the participant, Investigator, GSK or ViiV Healthcare;
- The participant requires concurrent prohibited medications during the course of the study. The participant may remain in the study if in the opinion of the Investigator and the medical monitor; such medication will not interfere with the conduct or interpretation of the study or compromise the safety of the participant.

**Participants must be discontinued from study treatment for any of the following reasons:**

- Participants who are not eligible to continue into the Maintenance Phase.
- Participants who are not eligible, or do not wish to continue on to the Extension Phase.
- Virologic withdrawal criteria as specified in Section 5.5.4 are met;
- Participant requires substitution of ART;
- Participant requires substitution or dose reduction of CAB LA or RPV LA (oral bridging supply and potential for a second loading dose may be permissible following discussion with the Medical Monitor).
- Liver toxicity where stopping criteria are met and no compelling alternate cause is identified (see Section 5.5.1);
- Renal toxicity are met and no compelling alternate cause is identified;
- QT interval (QTc) interval >550 msec from three or more tracings separated by at least 5 minutes and considered causally related to IP.
- Grade 4 clinical AE considered causally related to study drug;
- Participant has a Grade 3 or higher rash or Grade 2 rash with evidence of systemic involvement and no compelling alternative cause is identified
- Participant withdrew consent

Efficacy data for participants withdrawing from the study will be considered evaluable up to the point at which they are withdrawn using the same criteria for evaluability as for participants who complete the study.



Safety data for all participants who receive any amount of study drug, including participants who withdraw from the study, will be included in evaluations of safety.

All data from the Withdrawal visit will be recorded, as they comprise an essential evaluation that should be done prior to discharging any participant from the study.

The following actions must be taken in relation to a participant who fails to attend the clinic for a required study visit:

- a. The site must attempt to contact the participant and re-schedule the missed visit as soon as possible.
- b. The site must counsel the participant on the importance of maintaining the assigned visit schedule and ascertain whether or not the participant wishes to and/or should continue in the study.
- c. In cases where the participant is deemed 'lost to follow up', the investigator or designee must make every effort to regain contact with the participant (where possible, 3 telephone calls and if necessary a certified letter to the participant's last known mailing address or local equivalent methods). These contact attempts should be documented in the participant's medical record.
- d. Should the participant continue to be unreachable, only then will he/she be considered to have withdrawn from the study with a primary reason of "Lost to Follow-up".

A participant may withdraw from study treatment at any time at his/her own request, or may be withdrawn at any time at the discretion of the investigator for safety, behavioral or administrative reasons. If a participant withdraws from the study, he/she may request destruction of any samples taken, and the investigator must document this in the site study records. Please refer to Section 11.5 for additional guidance for sample destruction request.

### 5.5.1. Liver Chemistry Stopping Criteria

**Liver chemistry stopping and increased monitoring criteria** have been designed to assure participant safety and evaluate liver event etiology.

IP will be stopped if any of the following liver chemistry criteria are met:

- ALT  $\geq 3xULN$  and bilirubin  $\geq 2xULN$  (>35% direct bilirubin, bilirubin fractionation required).
- NOTE: serum bilirubin fractionation should be performed if testing is available. If testing is unavailable, sites should evaluate the presence of detectable urinary bilirubin on dipstick, indicating direct bilirubin elevations and suggesting liver injury. If testing is unavailable and a participant meets the criterion of total bilirubin  $\geq 2xULN$ , then the event meets liver stopping criteria.
- ALT  $\geq 8xULN$ .

- ALT  $\geq 3$ xULN (if Baseline ALT is  $< \text{ULN}$ ) with symptoms or worsening of acute hepatitis or hypersensitivity such as fatigue, nausea, vomiting, right upper quadrant pain or tenderness, fever, rash, or eosinophilia, OR;
- ALT  $\geq 3$ x Baseline ALT with symptoms or worsening of acute hepatitis or hypersensitivity such as fatigue, nausea, vomiting, right upper quadrant pain or tenderness, fever, rash, or eosinophilia;
- ALT  $\geq 5$ xULN and  $< 8$ xULN that persists  $\geq 2$  weeks (with bilirubin  $< 2$  ULN & no signs or symptoms of acute hepatitis or hypersensitivity).
- ALT  $\geq 5$ xULN but  $< 8$ xULN and cannot be monitored weekly for  $> 2$  weeks.

#### **5.5.1.1. Liver Chemistry Stopping Criteria, Participant Management and Follow-Up**

Participants who develop ALT  $\geq 5$ xULN must be followed weekly until resolution or stabilization (ALT  $< 5$ xULN on 2 consecutive evaluations).

#### **When any of the liver chemistry stopping criteria is met, do the following:**

- Immediately hold IP. If on LA therapy, **do not** administer another injection until approval is received from the ViiV Safety and Labelling Committee.
- Report the event to the Medical Monitor within 24 hours of learning its occurrence.
- Complete the liver event eCRF and SAE eCRF, where applicable.
- Complete the liver imaging and/or liver biopsy eCRFs if these tests are performed.
- Perform liver event follow up assessments (described below), and monitor the participant until liver chemistries resolve, stabilize, or return to Baseline values as described below.
- Make every reasonable attempt to have participants return to clinic within 24 hours for repeat liver chemistries, liver event follow-up assessments (see below), and close monitoring.
- A specialist or hepatology consultation is recommended.
- Monitor participants twice weekly until liver chemistries (ALT, AST, alkaline phosphatase, bilirubin) resolve, stabilize or return to within Baseline values.

Make every attempt to carry out the **liver event follow-up assessments** described below:

- Viral hepatitis serology including:
  - Hepatitis A immunoglobulin M (IgM) antibody;
  - Hepatitis B surface antigen (HBsAg) and Hepatitis B Core Antibody (IgM);
  - Hepatitis C RNA;
  - Hepatitis E IgM antibody;
  - Cytomegalovirus IgM antibody;

- Epstein-Barr viral capsid antigen IgM antibody (or if unavailable, obtain heterophile antibody or monospot testing);
- Syphilis screening;
- Drugs of abuse screen including alcohol;
- Serum acetaminophen test (N-acetyl-para-aminophenol [APAP] adduct test). The site must contact GSK when this test is required. Please refer to the central laboratory manual.
- Blood sample for pharmacokinetic (PK) analysis, obtained during follow up assessments. Record the date/time of the PK blood sample draw and the date/time of the last dose of investigational product prior to blood sample draw on the eCRF. If the date or time of the last dose is unclear, provide the participant's best approximation. If the date/time of the last dose cannot be approximated OR a PK sample cannot be collected in the time period indicated above, do not obtain a PK sample. Instructions for sample handling and shipping are in the SPM.
- Serum creatine phosphokinase (CPK) and lactate dehydrogenase (LDH);
- Fractionated bilirubin, if total bilirubin is greater than 1.5xULN;
- Obtain complete blood count with differential to assess eosinophilia;
- Anti-nuclear antibody, anti-smooth muscle antibody, and Type 1 anti-liver kidney microsomal antibodies, and quantitative total immunoglobulin G (IgG or gamma globulins);
- Liver imaging (ultrasound, magnetic resonance, or computerized tomography) and/or liver biopsy to evaluate liver disease; complete Liver Imaging and/or Liver Biopsy CRF forms.
- Record the appearance or worsening of clinical symptoms of hepatitis, or hypersensitivity, fatigue, decreased appetite, nausea, vomiting, abdominal pain, jaundice, fever, or rash as relevant on the AE report form;
- Record use of concomitant medications, acetaminophen, herbal remedies, other over the counter medications, or putative hepatotoxins, on the concomitant medications report form. Record alcohol use on the liver event alcohol intake case report form.

#### **5.5.1.2. Liver Event Adjudication Committee**

A liver safety panel will be used to evaluate all participants who meet liver stopping criteria. Uniform sets of data and standards for adjudication will be applied across cases to inform outcomes. Full details of the analysis, timing, and the decision criteria will be pre-specified in an Adjudication Committee Charter.

#### **5.5.1.3. Liver Chemistry Stopping Criteria – Restart**

Participants who meet liver toxicity stopping criteria should not be retreated with investigational product unless an exemption has been approved by the ViiV Safety and Labeling Committee (VSLC). The guideline for Restart approved by the VSLC, which is maintained as a separate document must be followed.

#### 5.5.1.4. General Guidance Restart

- The definition of ‘restart’ is not always clear cut in medical practice. Restarts should be limited to cases in which there is clear evidence that the underlying cause of the liver event is not related to study drug.
- For long acting agents, a restart may actually be continuation of therapy rather than a true re-start due to the timeframe between dose administration relative to decision making on allowing a restart.
- If protocol defined stopping criteria for liver chemistry elevations are met (see Section 5.5.1), study drug must be stopped. Participants who meet liver chemistry stopping criteria should not be retreated with investigational product unless an exemption has been approved by the VSLC. The guideline for Restart approved by the VSLC, which is maintained as a separate document must be followed.
- If the restart is approved by the VSLC in writing, the participant must be provided with a clear description of the possible benefits and risks of drug administration, including the possibility of recurrent, more severe liver injury or death.
- Ethics Committee or Institutional Review Board approval of drug restart must be obtained, as required.
- The participant must also provide signed informed consent specifically for the IP restart. Documentation of informed consent must be recorded in the study chart.
- Study drug must be administered at the dose specified by the VSLC.
- Participants approved by the VSLC for restart of IP must return to the clinic once a week for liver chemistry tests for a minimum of one month and thereafter for as long as clinically indicated and then laboratory monitoring may resume as per protocol. Longer durations of close monitoring may be required for long acting IP.

##### 5.5.1.4.1. Drug Restart

“Drug restart” can be approved by the VSLC for **defined non-drug-induced** liver injury if no evidence of:

- immunoallergic injury /HLA association with injury
- alcoholic hepatitis

Study drug must be held while labs and evaluation are completed to assess diagnosis.

If participant meets liver chemistry stopping criteria do not restart the participant with study treatment unless:

- ViiV Healthcare Safety and Labelling Committee (VSLC) approval **is granted**,

- Ethics and/or IRB approval is obtained, if required, and
- Separate consent for treatment restart is signed by the participant.

Refer to Section 11.3 for full guidance.

#### Background

- Restarts should be limited to cases in which there is clear evidence that the underlying cause of the liver event is not related to study drug.
- For long-acting agents, a restart may actually be continuation of therapy rather than a true re-start due to the timeframe between dose administration relative to decision making on allowing a restart.
- If protocol defined stopping criteria for liver chemistry elevations are met (Section 11.3), study drug must be stopped. Subjects who meet liver chemistry stopping criteria should not be retreated with investigational product unless an exemption has been approved by the VSLC. The algorithm for restart is described in Section 11.3 and summarised in Figure 8.
- If the restart is approved by the VSLC in writing, the subject must be provided with a clear description of the possible benefits and risks of drug administration, including the possibility of recurrent, more severe liver injury or death.
- Ethics Committee or Institutional Review Board approval of drug restart must be obtained, as required.
- The subject must also provide signed informed consent specifically for the IP restart. Documentation of informed consent must be recorded in the study chart.
- Study drug must be administered at the dose specified by the VSLC.
- Subjects approved by the VSLC for restart of IP must return to the clinic once a week for liver chemistry tests for a minimum of one month and thereafter for as long as clinically indicated and then laboratory monitoring may resume as per protocol. Longer durations of close monitoring may be required for long-acting IP.

Refer to Section 11.3 for full guidance.

#### **5.5.1.4.2. Drug Restart Following Transient Resolving Liver Events Not Related to IP**

Approval by the VSLC for drug restart or additional IM administration can be considered where:

- Abnormalities in liver chemistries have a clear underlying cause (e.g., biliary obstruction, hypotension, acute viral hepatitis) and liver chemistries have significantly improved.
- If definitive non-study drug related diagnosis, restart will be considered once ALT < 3x ULN (for participants with baseline ALT < 1.5x ULN) or < 3x baseline ALT value (for participants with baseline ALT > 1.5x ULN).
- Ethics Committee or Institutional Review Board approval of drug restart must be obtained, as required.
- If restart / redosing of drug is approved by the VSLC in writing, the participant must be provided with a clear description of the possible benefits and risks of drug administration, including the possibility of recurrent, more severe liver injury or death.
- The participant must also provide signed informed consent specifically for the restart. Documentation of informed consent must be recorded in the study chart.

Study drug must be administered at the dose specified by the VSLC. Participants approved by the VSLC for restarting or re-dosing IP must return to the clinic once a week for liver chemistry tests for a minimum of one month and thereafter for as long as clinically indicated and then laboratory monitoring may resume as per protocol. If protocol defined stopping criteria for liver chemistry elevations are met, study drug must be stopped.

### 5.5.2. QTc Stopping Criteria

A participant who has a QTc interval >550 msec considered causally related to IP will be withdrawn from the study. The QTc should be based on averaged QTc values of triplicate electrocardiograms obtained over a brief (e.g., 5 to 10 minute) recording period.

If an alternative cause of the QT prolongation is determined (e.g., participant receiving drug known to cause prolonged QT or TdP), the IP may be restarted (or continued) after consultation and agreement with the Medical Monitor. RPV and RPV LA should not be administered to patients who are receiving a drug known to be associated with TdP.

When performing ECGs, the *same* QT correction formula *must* be used for *each individual participant* to determine eligibility for, and discontinuation from, the study. This formula may not be changed or substituted once the participant has been enrolled.

For example, if a participant is eligible for the protocol based on QTcB, then QTcB must be used for discontinuation of this individual participant as well.

Once the QT correction formula has been chosen for a participant's eligibility, the *same formula* must continue to be used for that participant *for all QTc data being collected for data analysis*. Safety ECGs and other non-protocol specified ECGs are an exception.

### **5.5.3. Virologic Failure**

Only plasma HIV-1 RNA values determined by the central laboratory will be used to assess virologic failure.

### **5.5.4. Definition of Protocol-Defined Confirmed Virologic Failure**

For the purposes of clinical management in this study, CVF is defined as:

Rebound as indicated by two consecutive plasma HIV-1 RNA levels  $\geq 200$  c/mL after prior suppression to  $< 200$  c/mL.

### **5.5.5. Managing Virologic Failure**

Following study entry, no changes, or intensification of ART will be permitted prior to protocol-defined virologic failure, outside of the planned protocol regimens. Only plasma HIV-1 RNA values determined by the central laboratory will be used to assess virologic failure. Baseline plasma HIV-1 RNA is the assessment completed on study Day 1. The definition of confirmed virologic failure does not apply to participants in the LTFU Phase. These participants will be followed for the emergence of viral resistance.

Inadequate adherence is a common cause for virologic failure, and should be explored as a first step in the management of study participants (e.g., at the first indication of inadequate virologic response or rebound). Upon notification that a participant's HIV-1 RNA plasma level qualifies him/her as a suspected virologic failure, the Investigator should query the participant regarding intercurrent illness, recent immunization, or interruption of oral therapy.

#### **5.5.5.1. HIV-1 RNA Blips**

HIV-1 RNA “blips” are not usually associated with subsequent virologic failure [DHHS, 2016]. Although the implications of persistent HIV-1 RNA levels between the lower level of detection and  $< 200$  c/mL are unclear, the risk of emerging resistance is believed to be relatively low.

Participants with transient increases in HIV-1 RNA (‘blips’ HIV-1 RNA  $< 200$  c/mL) are not considered suspected virologic failures and do not require a change in therapy.

Participants who have a HIV-1 RNA  $\geq 50$  c/mL and  $< 200$  c/mL at the key analysis timepoints (Week 48, Week 96, and Week 152) must return to the clinic as soon as possible (but no later than 4 weeks after the date of the Week 48, 96, or 152 visit, respectively) for a repeat HIV-1 RNA test such that the result falls within the same analysis window.

In order to better characterize HIV-1 RNA ‘blips,’ if there is a known reason / explanation for the blip (e.g., immunization, allergies, etc.), the study team should be notified of the reason and case context.

If the Investigator has concerns regarding persistent low level viremia (HIV-1 RNA  $\geq 50$  c/mL and  $< 200$  c/mL), the Medical Monitor should be contacted to discuss participant management. Following discussion with the Medical Monitor, additional viral load testing may be performed between visits to determine the appropriate participant disposition for the next scheduled visit

#### **5.5.5.2. Suspected Virologic Failure**

Upon notification that a participant's HIV-1 RNA plasma level meets the definition of virologic failure, the Investigator should confirm the definition is met by initiating a repeat of the HIV-1 RNA assessment.

The following guidelines should be followed for scheduling confirmatory HIV-1 RNA testing in an effort to avoid false-positive results:

- Confirmatory testing should be scheduled within 2 to 4 weeks following resolution of any intercurrent illness, during which time the participant should receive full dose of all IP.
- Confirmatory testing should be scheduled at least 4 weeks following any immunization, during which time the participant should receive full dose of all IP.
- If therapy is interrupted\* due to toxicity management, non-compliance, or other reasons, confirmatory testing should be scheduled 2 to 4 weeks following resumption of full dose of all IP.
- The participant should have received full dose of IP for at least 2 weeks at the time confirmatory plasma HIV-1 RNA testing is done.

\*Note: treatment interruption guidelines above may not apply for participants on CAB LA + RPV LA treatment. The study team should be contacted to discuss any treatment interruptions for participants meeting the definition of virologic failure.

In addition, the Investigator should query the participant regarding intercurrent illness, recent immunization, or interruption of therapy.

**Sites should contact the Medical Monitor to discuss individual participants, whenever necessary.**

#### **5.5.5.3. Confirmed Virologic Failure**

Participants with confirmed virologic failure (CVF) must be discontinued from study treatment. However, participants who have received at least one dose of CAB LA or RPV LA prior to confirming virologic failure will remain in the study on oral HAART in the LTFU Phase.

A plasma sample from the suspected virologic failure visit as well as Day 1 (if baseline HIV-1 RNA level  $\geq 200$  c/mL) will be sent for genotypic and phenotypic resistance testing and the result made known to the Investigator when available. A plasma sample from the confirmation visit will be obtained for storage. This sample may be used for



possible future analyses, e.g., for genotypic and phenotypic analyses of participants who experience virologic failure.

For all participants who meet CVF, baseline and suspected virologic failure plasma samples with HIV-1 RNA level  $\geq 200$  c/mL will be analyzed in an attempt to obtain genotype/phenotype data on as many samples as possible. Plasma samples for storage will also be obtained at unscheduled visits including confirmation of CVF. Participants may continue to receive study drug at the discretion of the investigator until results of resistance testing are available at which time the participant must be discontinued from the study. Even if genotype/phenotype data cannot be generated, participant must also be discontinued from the study treatment.

If a participant is prematurely discontinued from the study treatment, the investigator must make every effort to perform the Withdrawal Visit evaluations outlined in the Time and Events. These data will be recorded as they comprise essential evaluations needed to be done before discharging any participant from the study.

## **5.6. Participant and Study Completion**

The investigator is responsible for ensuring that consideration has been given to the post-study care of the participant's medical condition.

### **Study Completion**

Participants are considered to have completed the study if they remain on therapy (i.e., have not permanently discontinued IP) and satisfy one of the following:

- Randomly assigned to either treatment group, completed the randomized Maintenance Phase including Week 100 (with or without Week 100 study treatment) and did not enter the Extension Phase;
- Randomly assigned to either treatment group, completed the randomized Maintenance Phase including Week 100, and entered and completed the Extension Phase (defined as remaining on study until commercial supplies of CAB LA + RPV LA Q4W or Q8W regimen become locally available or development of CAB LA + RPV LA is terminated).

Participants who withdraw from CAB LA + RPV LA and go into the LTFU Phase will be considered to have prematurely withdrawn from the study treatment.

### **Safety Follow Up visit:**

In addition to the 52-week Follow-Up phase required for participants who receive one or more injections with CAB LA or RPV LA, an in-clinic or telephone Follow-Up visit will be conducted as described below

1. **Where marketed CAB + RPV LA is locally available:** Safety Follow Up Visit is required for subjects completing the study, (may or may not be transitioning to CAB + RPV LA marketed product). It should be conducted approximately 2-4 weeks after the last dose of IP to assess HIV associated conditions, AEs, Concomitant medications, ISR AEs after the last injection and the plan to transition to marketed product. This visit may be conducted by telephone. Ensure relevant eCRF forms (including the Conclusion Visit) are updated / completed.
2. **Where marketed CAB + RPV LA is not yet locally available:**
  - a. Safety Follow Up Visit should be conducted approximately 2-4 weeks after the last dose of IP and may be conducted by telephone. Ensure relevant eCRF forms (including the Conclusion Visit) are updated / completed. This visit is only required if the subject:
    - i. has ongoing AEs or Lab abnormalities in the last on-study visit  
**AND**
    - ii. is not planning to attend additional study visits after the last IP injection (ie. Withdrawal visit, Long Term Follow up visits) where the ongoing AEs/Lab abnormalities can be assessed.
  - b. Safety Follow Up Visit is **not** required if the subject completes Withdrawal visit as scheduled and/or is willing to enter Long Term Follow Up phase. **Note:** If the first study visit after the last injection is scheduled more than 3 months after the last dose of IP, please consult the MM to advise if Safety Follow Up is still required.

## 6. STUDY TREATMENT

### 6.1. Investigational Product and Other Study Treatment

The term ‘study treatment’ is used throughout the protocol to describe any combination of products received by the participant as per the protocol design. **Study treatment is defined as any investigational treatment(s), marketed product(s), placebo, or medical device(s) intended to be administered to a study participant according to the study protocol.** Study treatment may therefore refer to the individual study treatments or the combination of those study treatments.

Investigational product (IP) in this protocol refers to the investigational study drugs Oral Cabotegravir, Cabotegravir LA, Oral Rilpivirine and Rilpivirine LA. These will be supplied by GlaxoSmithKline/ViiV Healthcare and Janssen Pharmaceuticals, respectively.

Participants entering the Long-Term Follow-Up Phase will not have their selected HAART provided as clinical trial material. The selected HAART will be recorded on the Concomitant Antiretroviral Therapy (ConART) eCRF page.

### **6.1.1. Formulations of CAB + RPV**

#### **6.1.1.1. Cabotegravir Tablets (CAB)**

CAB is manufactured by GlaxoSmithKline and is formulated as white to almost white oval shaped film coated 30 mg tablets for oral administration, packaged in high density polyethylene (HDPE) bottles with desiccant and child-resistant closure that include an induction seal. CAB tablets will be packaged in bottles of 30 tablets. Participants must keep all IP in its original pack container. GSK will notify sites if and when data are available to support the use of pill boxes. CAB tablets are to be stored according to the product labeling.

CAB Tablet is composed of cabotegravir sodium, lactose monohydrate, microcrystalline cellulose, hypromellose, sodium starch glycolate, magnesium stearate, and white film-coating. The white film-coating contains hypromellose, titanium dioxide and polyethylene glycol.

#### **6.1.1.2. Rilpivirine Tablets (RPV)**

RPV is provided by Janssen Research & Development, LLC, a division of Janssen Pharmaceuticals, as 25 mg tablets that are off-white, round, biconvex, film-coated and debossed on one side with “TMC” and the other side with “25”. RPV is manufactured by Janssen-Cilag S.p.A, Latina, Italy. RPV will be provided as a globally marketed product which includes approvals in the US and the European Union. RPV will be overlabeled and packaged in bottles of 30 tablets. RPV tablets should be stored according to the product labeling.

Each tablet contains 27.5 mg of rilpivirine hydrochloride, which is equivalent to 25 mg of RPV. Each tablet also contains the inactive ingredients croscarmellose sodium, lactose monohydrate, magnesium stearate, polysorbate 20, povidone K30 and silicified microcrystalline cellulose. The tablet coating contains hypromellose 2910 6 mPa.s, lactose monohydrate, PEG 3000, titanium dioxide and triacetin.

#### **6.1.1.3. Cabotegravir Injectable Suspension (CAB LA)**

CAB LA (GSK1265744 LA) is manufactured by GlaxoSmithKline and is a sterile white to slightly pink suspension containing 200 mg/mL of GSK1265744 as free acid for administration by intramuscular (IM) injection. The product is packaged in a glass vial with a 13 mm gray stopper and aluminum seal. Each vial is for single-dose use containing a withdrawable volume of 2.0 mL (400 mg) or 3 mL (600 mg) and does not require dilution prior to administration. CAB LA injectable suspension is to be stored according to the product labeling.

CAB LA is composed of cabotegravir free acid, polysorbate 20, polyethylene glycol 3350, mannitol, and water for injection.

#### **6.1.1.4. Rilpivirine Injectable Suspension (RPV LA)**

RPV LA (also named JNJ-16150108-AAA), 300 mg/mL Extended Release Suspension for Injection (G001), is provided by Janssen Research & Development, LLC, a division

of Janssen Pharmaceuticals, as a sterile white suspension containing 300 mg/mL of RPV as the free base. The route of administration is by intramuscular (IM) injection. RPV LA is packaged in a single use 4 mL glass vial with a 13 mm grey stopper and aluminum seal. Each vial contains a nominal fill of 2.0 mL (600 mg) or 3.0 mL (900 mg), and does not require dilution prior to administration. RPV LA injectable suspension is to be stored according to product labeling. RPV LA should also be protected from light.

RPV LA is composed of RPV free base, poloxamer 338, sodium dihydrogen phosphate monohydrate, citric acid monohydrate, glucose monohydrate, sodium hydroxide, water for injection.

## 6.2. Treatment Assignment

Informed consent must be obtained prior to any study procedures, including Screening visit activities. Participants will be assigned to study treatment in accordance with the randomization schedule. The randomization schedule, including stratification, will be generated using the GSK validated randomization software RANDALL NG. The randomization schedule is comprised of a series of blocks, with equal treatment allocation within each block, which are shared across centers via central randomization. Given the open-label study design, central randomization was used to eliminate selection bias due to foreknowledge of randomized treatment. With central randomization, knowledge at a site of the randomized treatment group for previous subjects does not predict which treatment group will be assigned to the next randomized subject.

Randomization and study treatment assignment will be facilitated by the interactive response technology (IRT) through the central Randomization and Medication Ordering System Next Generation (RAMOS NG).

Following confirmation of fulfillment of study entry criteria, study site personnel will be required to register participants using RAMOS NG for assignment of a unique identifier (designating the participant's randomization code and treatment sequence assignment) for each participant participating in the study. A unique treatment number will be assigned for each participant participating in the study. Participants will be randomized in a 1:1 ratio to CAB LA + RPV LA Q4W or to CAB LA + RPV LA Q8W in accordance with the computer generated randomization schedule.

Participants who successfully complete 100 weeks of treatment and have a viral load <50 c/ml at Week 96 (or upon retest by Week 100) will be given the opportunity to enter the Extension Phase in which they will continue to receive their CAB LA + RPV LA regimen. In addition, RAMOS NG will facilitate the initial supply and subsequent resupply of IP to study sites.

## 6.3. Dosage and Administration

Participants will be randomly assigned to receive treatment with CAB LA + RPV LA either Q4W or Q8W. Patients transitioning from oral standard of care therapy will initiate their randomized treatment regimen with Oral CAB 30 mg + RPV 25 mg once daily for 4 to 5 weeks during the Oral Phase, followed by CAB LA + RPV LA IM injections initiating at Week 4b. Patients transitioning from the ATLAS study and on CAB LA + RPV LA Q4W treatment will be randomized at Day 1 to either continue Q4W

administration or transition to Q8W administration of CAB LA + RPV LA. Regardless of treatment arm assignment, the investigator should instruct all participants on the importance of treatment adherence. This study has an open-label design. Dosing is outlined in [Table 7 Figure 8](#) below.

**Table 7 Dosage and Administration**

<b>Maintenance Phase and Extension Phase (Day 1 to End of Study<sup>+</sup>)</b>	
<b><u>Q4W Arm - Transitioning from SOC</u></b>	
<b>Oral Lead-In</b>	
Day 1 to Week 4b (2 tablets once daily)	<ul style="list-style-type: none"> <li>• Take 1 tablet CAB 30 mg once daily.</li> <li>• Take 1 tablet RPV 25 mg once daily.</li> </ul> <p><i>Should be taken together once daily at approximately the same time each day, with a meal.</i></p>
<b>First Injections (Loading Dose) – Week 4b</b>	
Week 4b (two 3mL injections once)	<ul style="list-style-type: none"> <li>• Receive last dose of oral CAB + RPV regimen</li> <li>• Receive CAB LA 600 mg given as 1 X <b>3 mL</b> IM injection</li> <li>• Receive RPV LA 900 mg given as 1 X <b>3 mL</b> IM injection</li> </ul>
<b>Maintenance Injections – every 4 Weeks (Q4W) following Week 4b</b>	
Week 8 to End of Study <sup>+</sup> (two 2 mL injections every 4 weeks)	<ul style="list-style-type: none"> <li>• Receive CAB LA 400 mg given as 1 X <b>2 mL</b> IM injection</li> <li>• Receive RPV LA 600 mg given as 1 X <b>2 mL</b> IM injection</li> </ul>
<b><u>Q8W Arm-Transitioning from SOC</u></b>	
<b>Oral Lead-In</b>	
Day 1 to Week 4b (2 tablets once daily)	<ul style="list-style-type: none"> <li>• Take 1 tablet CAB 30 mg once daily.</li> <li>• Take 1 tablet RPV 25 mg once daily.</li> </ul> <p><i>Should be taken together once daily at approximately the same time each day, with a meal.</i></p>
<b>First Injections (Loading Doses) – Week 4b</b>	
Week 4b (two 3 mL injections once)	<ul style="list-style-type: none"> <li>• Receive last dose of oral CAB + RPV regimen</li> <li>• Receive CAB LA 600 mg given as 1 X <b>3 mL</b> IM injection</li> <li>• Receive RPV LA 900 mg given as 1 X <b>3 mL</b> IM injection</li> </ul>

<b>Maintenance Injections – every 8 Weeks (Q8W) following Week 8</b>	
Week 8 to End of Study+ (two 3mL injections every 8 weeks)	<ul style="list-style-type: none"> <li>• Receive CAB LA 600 mg given as 1 X 3 mL IM injection</li> <li>• Receive RPV LA 900 mg given as 1 X 3 mL IM injection</li> </ul>
<b><u>Q4W Arm – Continuing Q4W injections from ATLAS</u></b>	
Day 1 to End of Study+ (two 2 mL injections every 4 weeks)	<ul style="list-style-type: none"> <li>• Receive CAB LA 400 mg given as 1 X 2 mL IM injection</li> <li>• Receive RPV LA 600 mg given as 1 X 2 mL IM injection</li> </ul>
<b><u>Q8W Arm- Transitioning from ATLAS Q4W</u></b>	
Day 1 to End of Study+ (two 3 mL injections every 8 weeks)	<ul style="list-style-type: none"> <li>• Receive CAB LA 600 mg given as 1 X 3 mL IM injection</li> <li>• Receive RPV LA 900 mg given as 1 X 3 mL IM injection</li> </ul>
<p>+Until locally approved and commercially available, the participant no longer derives clinical benefit, the participant meets a protocol-defined reason for discontinuation or until development of CAB LA or RPV LA is terminated Participants will be given an option to continue their randomized Q4W or Q8W CAB LA + RPV LA regimen (or complete trial participation) at Week 100. If the participant decides not to continue participation in the study, any arrangements for off-study ART should be made in advance of the Week 100 visit. ^See Section 6.6.1 for Dosing Considerations for CAB LA + RPV LA</p>	

#### **6.4. Blinding**

This will be an open-label study and therefore no blinding is required. No summaries of the study data according to actual randomized treatment groups will be available to sponsor staff prior to the planned Week 24 preliminary analysis. The Week 24 results will be restricted to only those study team members and GSK/ViiV Healthcare senior management who need to be involved in the analysis and interpretation of the results for reporting to regulatory authorities. Public presentation of the Week 24 analysis will not be done prior to Week 48 analysis complete.

#### **6.5. Packaging and Labeling**

The contents of the label will be in accordance with all applicable regulatory requirements.

#### **6.6. Preparation/Handling/Storage/Accountability**

- The investigator or designee must confirm appropriate temperature conditions have been maintained during transit for all study treatment received and any discrepancies are reported and resolved before use of the study treatment.
- Only participants enrolled in the study may receive study treatment and only authorized site staff may supply or administer study treatment. All study treatments

must be stored in a secure, environmentally controlled, and monitored (manual or automated) area in accordance with the labeled storage conditions with access limited to the investigator and authorized site staff.

- In accordance with local regulatory requirements, the investigator, institution, or the head of the medical institution (where applicable) is responsible for study treatment accountability, reconciliation, and record maintenance (i.e. receipt, reconciliation and final disposition records). The amount of IP dispensed and/or administered to study participants, the amount returned by study participants, and the amount received from and returned to GSK must be documented.
- Further guidance and information for the final disposition of unused study treatment are provided in the Study Reference Manual.
- Under normal conditions of handling and administration, study treatment is not expected to pose significant safety risks to site staff. Take adequate precautions to avoid direct eye or skin contact and the generation of aerosols or mists. In the case of unintentional occupational exposure notify the monitor, Medical Monitor and/or GSK study contact.
- A Material Safety Data Sheet (MSDS)/equivalent document describing occupational hazards and recommended handling precautions either will be provided to the investigator, where this is required by local laws, or is available upon request from GSK.
- Product accountability records must be maintained throughout the course of the study.

IP accountability will be evaluated using pill counts of unused IP for patients receiving oral treatment (oral CAB, oral RPV). This assessment will be conducted, when the participant completes oral CAB and RPV lead-in treatment in the Maintenance or Extension Phase, or any withdrawal that occurs during an oral treatment phase.

IP accountability for participants receiving CAB LA + RPV LA will be performed at the 'vial' level (e.g., correct number of vials were used for each injection). There may be a small amount of solution remaining in the vial which does not require quantification. Used vials may be discarded at the site once accountability is complete.

Please refer to [Appendix 10](#) in Section [11.10](#) for study management information during the COVID-19 pandemic.

### **6.6.1. Dosing Considerations for CAB LA + RPV LA**

Vials of CAB LA and RPV LA are each supplied as a suspension and need no further dilution or reconstitution. Since RPV LA requires refrigeration, sites should allow the vial to come to approximately room temperature prior to injecting. The vials should be gently inverted a few times to re-suspend sediments and allow bubbles to subside, and then use a syringe to withdraw the required volume of suspension for IM injection.

All injections must be given intramuscularly in the gluteus medius. Sites may use their discretion as to where in the gluteus muscle each injection is given according to individual participant circumstance. If possible, injections should be spaced



approximately 2 cm from one another, from the site of any previous injection or any injection site reaction. The time and location of injection will be captured in the eCRF.

IM injections should be administered at a 90 degree angle into the gluteus medius muscle using a needle of appropriate gauge and length (In most participants, a 1.5” 23 gauge needle for CAB LA and a 1.5” 23 gauge needle for RPV LA is recommended). The needle should be long enough to reach the muscle mass and prevent study drug from seeping into subcutaneous tissue, but not so long as to involve underlying nerves, blood vessels, or bone. Variable needle lengths and/or needles with different gauge (CAB LA: 21 to 25 gauge; RPV LA: 21 to 23 gauge) are permitted if needed to accommodate individual body types. Longer needle lengths may be required for participants with higher body mass indexes (BMIs, example > 30), to ensure that injections are administered intramuscularly as opposed to subcutaneously. BMI, needle gauge and length used will be collected in the eCRF. Additional details of the injection device used by sites for IM administration including, but not limited to functional performance, may also be collected within the eCRF.

At the Week 4b visit, participants transitioning from oral SOC should be dosed with the IM regimen within 2 hours of taking the last oral regimen dose where possible.

Should IM maladministration be suspected at any time (e.g., suspected under or overdose or inadvertent IV dosing), the investigator may consider requesting the participant stay onsite for approximately 2-3 hours post dose for safety monitoring and notifying the Medical Monitor. An ECG or any other supportive testing may be obtained at the discretion of the investigator. Additionally, a PK sample may be drawn approximately 2 hours post dosing for future evaluation of CAB and RPV plasma concentrations.

Additional dosing instructions and considerations can be found in the SPM.

## **6.7. Compliance with Study Treatment Administration**

When participants are dosed at the site, they will receive study treatment directly from the investigator or designee, under medical supervision. The date and time of each dose administered in the clinic will be recorded in the participant’s eCRF. The dose of study treatment and study participant identification will be confirmed at the time of dosing by a member of the study site staff other than the person administering the study treatment.

When participants self-administer oral study treatments at home, compliance with CAB + RPV dosing will be assessed through querying the participant during the site visits and documented in the source documents and CRF. IP accountability will be evaluated using pill counts of unused IP (CAB and RPV tablets). This assessment will be conducted each time the participant receives a new (refill) supply of oral study medication, completes the oral lead-in or any oral bridging phase. A record of the number of CAB and RPV tablets dispensed to and taken by each participant must be maintained and reconciled with study treatment and compliance records. Treatment start and stop dates will also be recorded in the eCRF.

Due to the long acting nature of the CAB LA and RPV LA it will be imperative that the participant is compliant with dosing instructions. As part of the screening and participant selection process, it is imperative that Investigators discuss with potential participants the

long-term commitments for the trial, and the importance of adhering to treatment regimens. Sites are to have plans in place for adherence counselling for both treatment arms of the study for the duration of the study including the LTFU Phase. In addition, Investigators must have plans in place to perform visit reminders, utilizing patient trackers provided by the study team as needed, and to verify the participant's contact information at each visit. Investigators should contact patients directly in the event that a participant misses any scheduled visit.

## **6.8. Protocol Permitted Substitutions**

### **6.8.1. Oral Bridging**

In exceptional circumstances, to address pre-planned missed CAB LA + RPV LA dosing visits, in consultation with the medical monitor, Investigators may provide daily oral CAB 30 mg and RPV 25 mg as a short-term “bridging” strategy for participants who have begun CAB LA + RPV LA. In certain circumstances (e.g., prior to steady state dosing and following a >4 week oral bridge) repeating the loading doses of CAB IM and RPV IM may be required. **Participants who withdraw during an oral treatment period must be initiated on HAART therapy within 24 hours after the last oral treatment with CAB + RPV.** Should a participant require “oral bridging”, sites must contact the study Medical Monitor for guidance with treatment and dosing strategies prior to a missed CAB LA + RPV LA dose.

Please refer to [Appendix 10](#) in Section [11.10](#) for study management information during the COVID-19 pandemic.

## **6.9. Interruption of Study Treatment and Visit/Dosing Windows**

IP may be interrupted at the discretion of the Investigator in the event of an AE, according to the severity of the AE.

If one or more antiretroviral medications is held due to toxicity or adverse events, all antiretroviral medications must be held to reduce the risk of development of resistance taking into account both the length of the planned interruption and the pharmacokinetic half-life of each antiretroviral of the regimen, in a way to minimize the risk of development of resistance.

**It is important to note that keeping to the participant's visit schedule is a very important component to the study.**

**Note: All decisions regarding dose interruption / resumption must be discussed with the Medical Monitor in advance.**

### **6.9.1. IM Dosing**

Participants receiving CAB LA and/or RPV LA are anticipated to be at risk for development of virologic resistance if ART is interrupted. The time period during which participants are at risk for development of virologic resistance may be determined by the period between when drug levels fall below therapeutic values and when they fall below

levels which exert selective pressure on HIV. This time period will vary by ART agent and is dependent upon effective concentration, inhibitory concentration, and half-life. Plasma concentrations of both LA drugs may be measurable for more than one year following IM injections. Any interruption in IM dosing should be discussed with the Medical Monitor. Investigators should ensure that the participant initiates alternative highly active ART to minimize the risk of developing resistance as concentrations of CAB and RPV decline over time.

IM dosing is expected to occur during the week in which the participant's projected visit falls (as according to the date of the first injection). The first injections for participants from ATLAS on CAB LA + RPV LA Q4W will occur at Day 1. The first injections for participants transitioning from oral SOC are administered at Week 4b (can be performed as soon as lab results from Week 4a become available and should be performed where possible within 2 weeks of visit 4a), and the second injections are given at Week 8. Between the Week 4a and 4b visits, participants must continue daily treatment with oral CAB and RPV tablets.

Since the first injection visit (Day 1 or 4b) will determine the future injection visit schedule for participants, planning for the first injection visit date (within allowed visit windows) should take into consideration the availability of the participants to adhere to future visit windows (planned vacations, business trips, *etc.*).

**CAB LA + RPV LA dosing for participants transitioning from SOC treatment is as follows:**

All injections should be planned as single injections per drug.

**6.9.1.1. IM injections every 4 weeks (Q4W):**

Week 4b only - CAB LA 600 mg + RPV LA 900 mg, each given as 1 X 3 mL IM injection

Week 8 and Q4W thereafter - CAB LA 400 mg IM + RPV LA 600 mg IM every 4 weeks for 100 weeks, each given as 1 X 2 mL IM injection

At Week 4b, participants transitioning from SOC will return to the clinic, take the last dose of oral CAB 30 mg + RPV 25 mg, and receive the first CAB LA 600 mg + RPV LA 900 mg injections (within 2 hours of the final oral dose of CAB + RPV). The first injection visit with IM CAB LA + RPV LA at Week 4b can be performed once central lab results are available and safety parameters are reviewed from the Week 4a visit.

The second and third IM injections with CAB LA 400 mg and RPV LA 600 mg will be performed at Week 8 and Week 12. There will be a -7 day dosing window for the second and third IM injections such that the second injection occurs within the window of Week 7 and Week 8 but no later than Week 8 and the third injection occurs within the window of Week 11 and Week 12 but no later than Week 12. Subsequent injections with CAB LA 400 mg and RPV LA 600 mg will occur every 4 weeks ( $\pm 7$  days) thereafter. In addition, starting after the Week 16 injection, efforts should be made to limit time between injection visits to a maximum of 5 weeks. The Medical Monitor must be

contacted if the length of time between injections exceeds or is projected to exceed 5 weeks.

#### **6.9.1.2. IM injections every 8 weeks (Q8W):**

Week 4b – CAB LA 600 mg + RPV LA 900 mg IM, each given as 1 X 3 mL IM injection

Week 8 - CAB LA 600 mg + RPV LA 900 mg IM, each given as 1 X 3 mL IM injection

Week 16 and Q8W thereafter - CAB LA 600 mg + RPV LA 900 mg IM, every 8 weeks for 100 weeks, each given as 1 X 3 mL IM injection

At Week 4b, subjects will return to the clinic, take the last dose of their oral (CAB 30 mg + RPV 25 mg), and receive the first CAB LA (600 mg) + RPV LA (900 mg) injections (within 2 hours of the final oral dose of CAB + RPV). The first injection visit with IM CAB LA + RPV LA at Week 4b can be performed once central lab results are available and safety parameters are reviewed from the Week 4a visit.

The second loading injection will be administered at Week 8 (CAB LA 600 mg + RPV LA 900 mg, with subsequent injections (CAB LA 600 mg + RPV LA 900 mg) occurring every 8 weeks thereafter. The dosing window for the second injection allows administration between Week 7 and Week 8, but preferably not later than Week 8. After Week 16, a dosing window ( $\pm 7$  days) for injections is allowed, but not preferred. Starting at the Week 16 injection, the interval between injection visits should be limited to a maximum of 9 weeks. If the length of time between injections exceeds, or is projected to exceed 9 weeks, the Medical Monitor must be contacted to discuss individual subject case management

#### **Participants transitioning from ATLAS and currently receiving CAB LA + RPV LA Q4W**

Patient transitioning from the ATLAS study and on CAB LA + RPV LA Q4W treatment will be randomized at Day 1 to either continue Q4W administration or transition to Q8W administration of CAB LA + RPV LA. The first injection visit for the ATLAS-2M study can be performed once the final central lab results from the ATLAS study are available and safety parameters have been reviewed. For participants who received three or more Q4W CAB LA + RPV LA injections within ATLAS, the transition from ATLAS to ATLAS-2M Day 1 dosing must occur 4 weeks ( $\pm 7$  days) from the final injections received in ATLAS. For those who received less than three Q4W injections within ATLAS, this transition to ATLAS-2M Day 1 injections must occur within 4 weeks (-7 days) from the final ATLAS injections

Dosing for participants transitioning from CAB LA + RPV LA Q4W in ATLAS is as follows:

**6.9.1.3. IM injections every 4 weeks (Q4W) (Q4W from ATLAS Q4W):**

Starting at Day 1, all injections will continue with the maintenance dose of CAB LA 400 mg and RPV LA 600 mg administered every 4 weeks ( $\pm 7$  days). In addition, efforts should be made to limit time between injection visits to a maximum of 5 weeks. The Medical Monitor must be contacted if the length of time between injections exceeds or is projected to exceed 5 weeks.

**6.9.1.4. IM injections every 8 weeks (Q8W) (Q8W from ATLAS Q4W):**

Participants transitioning from ATLAS and receiving CAB LA + RPV LA Q8W will initiate dosing at the Day 1 visit:

Day 1- CAB LA 600 mg + RPV LA 900 mg IM, each given as 1 X 3 mL IM injection

Week 8 and Q8W thereafter- CAB LA 600 mg + RPV LA 900 mg IM, each given as 1 X 3 mL IM injection

The second injection will be administered at Week 8 (CAB LA 600 mg + RPV LA 900 mg, with subsequent injections (CAB LA 600 mg + RPV LA 900 mg) every 8 weeks thereafter. The dosing window for the second injection allows administration between Week 7 and Week 8, but preferably not later than Week 8. After Week 16, a dosing window ( $\pm 7$  days) for injections is allowed, but not preferred. Starting at the Week 16 injection, the interval between injection visits should be limited to a maximum of 9 weeks. If the length of time between injections exceeds, or is projected to exceed 9 weeks, the Medical Monitor must be contacted to discuss individual subject case management.

Any request for the visit/dosing to occur outside of the allowed window must be discussed and agreed with the Medical Monitor prior to dosing. In the event of a late dose, a revised dosing schedule for subsequent dosing may be required and will be communicated to the site staff at the time of approval for continued dosing. Temporary switch to oral dosing of CAB and/or RPV may be an option based on individual participant circumstance as described in Section 6.8.

See the SPM for scheduling guidance and further information and examples.

**Note: All decisions regarding dose interruption/ resumption must be discussed with the Medical Monitor in advance.**

**6.9.2. Oral Dosing**

The Week 4a Visit during the Oral Lead-in Phase for participants transitioning from SOC is expected to occur 4 weeks ( $\pm 3$  days) after to the Day 1 Baseline visit. However, the number of tablets dispensed should be considered when scheduling the next visit.

Any interruption in therapy (scheduling conflicts, life circumstances, *etc.*) during any oral dosing period that is greater than 7 consecutive days must be discussed with the Medical Monitor prior to resumption of therapy. The Medical Monitor must be contacted upon

site staff becoming aware of resumption in therapy, if therapy was resumed without prior approval.

Visits for participants in LTFU are expected to occur as projected according to the last injection.

### **6.10. Discontinuation of Study Treatment**

Participants unable to manage drug toxicity or tolerate investigational product (IP, either formulations of CAB or RPV) must have IP discontinued. Any participant receiving at least one dose of CAB LA and /or RPV LA who discontinues IP / Withdraw will initiate treatment with HAART enter the LTFU Phase for 52 weeks of follow-up (see Section 4.2.4).

When the CAB+RPV LA marketed product is locally available participants must enter the LTFU Phase if withdrawing for safety related reasons only. see Section 5.5.

### **6.11. Treatment of Study Treatment Overdose**

For participants receiving Oral CAB, any tablet intake exceeding a total daily dose of 30 mg will be considered an overdose. For participants receiving oral RPV, any dose exceeding a total daily dose of 25 mg will be considered an overdose.

For CAB LA and RPV LA, any single dose in excess of the studied doses will be considered an overdose.

Should IM maladministration, specifically overdose or inadvertent IV dosing, be suspected at any time, the participant will stay onsite for approximately 2-3 hours post dose for safety monitoring and an ECG will be performed at 2 hours post dose. The Medical Monitor will be notified in the event of a suspected maladministration.

In the event of suspected maladministration, additional PK samples will be drawn at 2 hours post dosing for evaluation of CAB and RPV concentrations.

For the purposes of this study, an overdose is not an AE (refer to Section 11.6.1 ) unless it is accompanied by a clinical manifestation associated with the overdose. If the clinical manifestation presents with serious criteria, the event is a SAE (see Section 11.6.2).

If an overdose occurs and is associated with an adverse event requiring action, all study medications must be temporarily discontinued until the adverse event resolves.

The Investigator should use clinical judgement in treating overdose, as ViiV Healthcare is unable to recommend specific treatment.

In the event of an overdose the investigator or treating physician should:

1. Contact the Medical Monitor immediately

2. Closely monitor the participant for adverse events (AEs)/serious adverse events (SAEs) and laboratory abnormalities until the IP can no longer be detected systemically (at least 5 days for oral CAB and oral RPV, and 52 weeks for CAB LA and RPV LA)
3. Obtain a plasma sample for pharmacokinetic (PK) analysis if possible within 2 days from the date of the last dose of study treatment if requested by the Medical Monitor (determined on a case-by-case basis).
4. Document the quantity of the excess dose as well as the duration of the overdosing in the CRF.

Decisions regarding dose interruptions or modifications will be made by the investigator in consultation with the Medical Monitor based on the clinical evaluation of the participant.

### **6.12. Treatment after the End of the Study**

The investigator is responsible for ensuring that consideration has been given to the post-study care of the participant's medical condition, whether or not GSK is providing specific post-study treatment. Participants who have successfully completed 100 weeks of treatment will continue to have access to both CAB LA and RPV LA in the Extension Phase through Week 152 and until study treatment is either locally approved and commercially available, the participant no longer derives clinical benefit, the participant meets a protocol-defined reason for discontinuation or until development of either CAB LA or RPV LA is terminated.

### **6.13. Concomitant Medications and Non-Drug Therapies**

Participants must be advised to notify their Investigator of any current or proposed concomitant medication, whether prescribed or over-the-counter, because of the potential for interactions between such treatments and the study medications. Concomitant medications (prescription and non-prescription) will be permitted during the course of the study at the investigator's discretion (except for prohibited medications described in Section 6.13.2) and should be administered only as medically necessary during the study. All concomitant medication, blood products, and vaccines taken during the study will be recorded in the eCRF. The minimum requirement is that the drug name, route, and the dates of administration are to be recorded.

Any medication or vaccine (including over-the-counter or prescription medicines, vitamins, and/or herbal supplements) that the participant is receiving at the time of enrollment or receives during the study must be recorded along with:

- reason for use
- dates of administration including start and end dates
- dosage information including dose and frequency

The Medical Monitor should be contacted if there are any questions regarding concomitant or prior therapy.

### 6.13.1. Permitted Medications and Non-Drug Therapies

Chemoprophylaxis for HIV-associated conditions is encouraged, if appropriate, at the discretion of the participant and their physician. All concomitant medications, blood products, and vaccines taken during the study will be recorded in the eCRF with dates of administration.

Because non-HIV vaccines may cause a temporary increase in the level of plasma HIV-1 RNA, it is recommended that a vaccine, if necessary, be given during or immediately after a scheduled visit after all laboratory tests have been drawn. This approach will minimize the risk of non-specific increases in the level of plasma HIV-1 RNA at the next scheduled assessment.

Other IM injectables (with exceptions below) are permitted but must be administered away from the site of IP administration (should be spaced 2 cm or more away from site of IP injection).

#### **Antacid and H2 Antagonist Use:**

Since co-administration of oral CAB and RPV is required in this study, the most restrictive dosing requirements must be taken into consideration.

**CAB oral administration only:** Antacid products containing divalent cations (e.g., aluminium, calcium and magnesium) must be taken at least 2 hours before or at least 4 hours after CAB.

Concurrent administration of multivitamins is acceptable.

**RPV oral administration only:** Antacid products must be taken at least 2 hours before or at least 4 hours after RPV. H2-Receptor antagonists (e.g. cimetidine, famotidine, nizatidine, ranitidine) may cause significant decreases in RPV plasma concentrations. H2-receptor antagonists should only be administered at least 12 hours before or at least 4 hours after RPV. RPV should not be co-administered with proton pump inhibitors, such as esomeprazole, lansoprazole, omeprazole, pantoprazole, rabeprazole.

**RPV:** Administration of clarithromycin, erythromycin and telithromycin is not recommended with RPV due to possible increase in plasma concentration of RPV due to CYP3A enzyme inhibition. Where possible, alternatives such as azithromycin should be considered. Please refer to the local rilpivirine prescribing information for guidance regarding other drugs that are prohibited, should be used with caution, require dose adjustment, or increased clinical monitoring if taken with rilpivirine.

Drugs with a known risk of Torsade des Pointes (TdP) should be used with caution when on rilpivirine (see SPM for list of drugs associated with TdP).

### 6.13.2. Prohibited Medications and Non-Drug Therapies

The following concomitant medications or therapies are not permitted at any time during the study:



- HIV immunotherapeutic vaccines are not permitted at any time during the study.
- Other experimental agents, antiretroviral drugs not otherwise specified in the protocol, cytotoxic chemotherapy, or radiation therapy may not be administered (see Exclusion Criteria #35-36, Section 5.2).
- Systemically administered immunomodulators (such as interleukin and interferon agents) are prohibited (a list of examples is provided in the SPM). This includes topical agents with substantial systemic exposure and systemic effects. Use of topical imiquimod is permitted.
- Acetaminophen (paracetamol) cannot be used in patients with acute viral hepatitis (James, 2009).
- Chronic use of systemic (oral or parenteral) glucocorticoids must be avoided due to their immunosuppressive effect; however, short treatment courses with oral prednisone/ prednisolone/methylprednisolone (e.g. adjunctive treatment of *Pneumocystis pneumonia* with  $\leq 21$  days of tapering prednisone) are allowed. A single dose of systemic dexamethasone is permitted (more than a single dose in a treatment course may cause significant decrease in RPV plasma concentration and is prohibited). Topical, inhaled or intranasal use of glucocorticoids will be allowed.
- Hepatitis C infection therapy is prohibited during the Maintenance Phase before the Week 48 primary endpoint, and interferon-based HCV therapy or use of any drugs that have a potential for adverse drug:drug interactions with study treatment is prohibited throughout the entire study.

For information on concurrent therapies and interactions suspected to be relevant to other antiretroviral therapy in the regimen, please consult the local prescribing information.

#### 6.13.2.1. Concurrent with CAB and/or RPV

For participants receiving **either formulation** of CAB and/or RPV, the following medications could significantly decrease the levels of CAB and/or RPV due to enzyme induction and therefore must not be administered concurrently:

- Carbamazepine
- Oxcarbazepine
- Phenobarbital
- Phenytoin
- Rifabutin
- Rifampicin / Rifampin
- Rifapentine
- St. John's wort (*Hypericum perforatum*)

#### Concurrent with CAB

CAB is a potent inhibitor of OAT1 and OAT3 transport in vitro, however, no clinically significant interaction risk is expected for most drugs that are substrates of these transporters. Monitoring may be required for drugs with a narrow therapeutic index and dependent on OAT1 and OAT3 transport (e.g. methotrexate) with concomitant CAB

administration. Refer to the current Investigator's Brochure (Section 4.3.6.1 and Section 6.4) for additional information.

### **Concurrent with RPV**

In addition, participants must discontinue the following (or change to an allowable alternative) while receiving treatment with oral RPV:

- proton pump inhibitors, such as esomeprazole, lansoprazole, omeprazole, pantoprazole, rabeprazole;
- systemic dexamethasone (more than a single dose)

If the participant cannot discontinue use or change to an allowable alternative while receiving treatment with RPV, the participant should not be randomized into the study.

#### **6.13.2.2. Concurrent with either CAB LA or RPV LA**

In addition, for participants receiving CAB LA and RPV LA, use of anticoagulation agents for greater than 14 days is prohibited, with the exception of the use of anticoagulation for deep vein thrombosis (DVT) prophylaxis (e.g., postoperative DVT prophylaxis) or the use of low dose acetylsalicylic acid ( $\leq 325$  mg). Systemic anticoagulation (including prophylaxis doses) on the day of an IM injection should be avoided.

Note: Any prohibited medications that decrease cabotegravir or rilpivirine concentrations should be discontinued for a minimum of four weeks or a minimum of three half-lives (whichever is longer) prior to the first dose and any other prohibited medications should be discontinued for a minimum of two weeks or a minimum of three half-lives (whichever is longer) prior to the first dose.

#### **6.13.2.3. Prohibited Medications for Participants Receiving HAART during the Long-Term Follow-Up Phase**

For participants taking HAART during the Long-Term Follow-Up Phase, refer to local prescribing information for details regarding concurrent therapies.

### **6.14. Medical Devices**

The medical devices to be used in this study are: vial adaptor, syringe and needle.

Instructions for medical device use are provided in the Study Reference Manual.

All device deficiencies, (including malfunction, use error and inadequate labelling) shall be documented, and reported by the investigator throughout the clinical investigation (see Section 11.2) and appropriately managed by the sponsor.

## 7. STUDY ASSESSMENTS AND PROCEDURES

Protocol waivers or exemptions are not allowed with the exception of immediate safety concerns. Therefore, adherence to the study design requirements, including those specified in the Time and Events Table, are essential and required for study conduct.

This section lists the procedures and parameters of each planned study assessment. The exact timing of each assessment is listed in the Time and Events Table (Section 7.1).

The following points must be noted:

- If assessments are scheduled for the same nominal time, THEN the assessments should occur in the following order:
  1. 12-lead ECG
  2. vital signs
  3. blood draws

Note: The timing of the assessments should allow the blood draw to occur at the exact nominal time.

- The timing and number of planned study assessments, including safety, pharmacokinetic, pharmacodynamic/biomarker assessments may be altered during the course of the study based on newly available data (e.g., to obtain data closer to the time of peak plasma concentrations) to ensure appropriate monitoring.
- The IRB/IEC will be informed of any safety issues that require alteration of the safety monitoring scheme or amendment of the Informed Consent Form.

Please refer to [Appendix 10](#) in Section 11.10 for study management information during the COVID-19 pandemic.

### 7.1. Time and Events Table

Note: While some assessments included in the Time and Events Table are conducted less frequently following the primary endpoint (Week 48), IM injections for participants during the Extension Phase will continue to be administered Q4W or Q8W based on original study randomization assignment.

All patients will be randomized at Day 1 to initiate either Q4 weekly or Q8 weekly administration of IM CAB LA + RPV LA. Only participants randomized from oral SOC treatment will participate in the Day 1 to Week 4 Oral CAB + Oral RPV lead-in treatment.





Procedure	Maintenance Phase																					Extension Phase			Withdrawal Assessments, <sup>y</sup> (Maintenance)	Withdrawal Assessments (Extension)	Long-Term Follow-up <sup>z</sup>	
	Screening Visit <sup>a</sup>		Week																									
	Day 1	Week 4A (Oral Lead-in Only) <sup>b</sup>	Week 4B	8	12	16	20	24	28	32	36	40	44	48	52	Q4W 56-92	Q8W 56-92	96	100	Q4W After Week 100	Q8W After Week 96	152						
HIV Associated Conditions		X	X	X	X	X	X	X	X	X	X	X	X	X	X	X	X	X	X	X	X	X	X	X	X	X	X	
AEs, SAEs, device deficiencies, Concomitant Medications <sup>i</sup>	X	X	X	X	X	X	X	X	X	X	X	X	X	X	X	X	X	X	X	X	X	X	X	X	X	X	X	X
ISR Assessment for IM injections		X		X	X	X	X	X	X	X	X	X	X	X	X	X	X	X	X	X	X	X	X	X	X	X	X	X
Columbia Suicide Severity Rating Scale (eC-SSRS) <sup>j</sup>	X	X		X	X		X		X		X		X		X		X	X								X		
Clinical chemistry and Hematology	X	X	X	X	X		X		X		X		X		X		X	X	X							X	X	X
Pregnancy Testing <sup>k</sup>	S	U	S	U	S	U	S	U	S	U	S	U	S	S	U	S	S	S	S	U	S	S	S	S	S	S	S	S

Procedure	Maintenance Phase																				Extension Phase					
	Week																				Withdrawal Assessments, <sup>y</sup> (Maintenance)	Withdrawal Assessments (Extension)	Long-Term Follow-up <sup>z</sup>			
	Screening Visit <sup>a</sup>	Day 1	Week 4A (Oral Lead-in Only) <sup>b</sup>	Week 4B	8	12	16	20	24	28	32	36	40	44	48	52	Q4W 56-92	Q8W 56-92	96	100				Q4W After Week 100	Q8W After Week 96	152
HIV-1 RNA and sample for storage (S) <sup>l</sup>	X	X	X	X	X		X		X		X		X	S		X	X	S		X	X		X	X		
CD4+ cell count	X	X		X	X		X		X		X		X			X	X				X	X		X	X	
CD8+ cell count		X						X					X				X					X		X		
Urinalysis <sup>m</sup>		X	X					X					X				X					X		X		
Fasting Lab Assessment: Glucose, Cholesterol (Total, HDL and LDL) and Triglycerides <sup>n</sup>		X											X					X					X		X <sup>o</sup>	
Hepatitis B (HBsAg), Anti-HBc, and Anti-HBsAG, Hepatitis C (anti-HCV Ab)	X																									
PT/PTT/INR	X	X																								
PBMCs <sup>p</sup>		X											X				X					X		X		
Genetics sample <sup>q</sup>		X																								

Procedure	Maintenance Phase																				Extension Phase			Withdrawal Assessments, <sup>y</sup> (Maintenance)	Withdrawal Assessments (Extension)	Long-Term Follow-up <sup>z</sup>
	Screening Visit <sup>a</sup>																									
	Day 1	Week																								
	Week 4A (Oral Lead-in Only) <sup>b</sup>	Week 4B	8	12	16	20	24	28	32	36	40	44	48	52	Q4W 56-92	Q8W 56-92	96	100	Q4W After Week 100	Q8W After Week 96	152					
PK sampling <sup>r</sup> (S)=Storage only			X	X	S	X	S	X	S	X	S	X	S	X	S	S	S	X	S			X	X		S	
Oral CAB and Oral RPV Dispensation <sup>s</sup>	X	X																								
IP accountability (Pill Counts) <sup>s</sup>		X	X																							
IM treatment administration when transitioning from SOC <sup>t</sup>			X	X	X	X	X	X	X	X	X	X	X	X	X	X	X	X	X	X	X	X				
IM treatment administration when transitioning from CAB + RPV LA Q4W	X		X	X	X	X	X	X	X	X	X	X	X	X	X	X	X	X	X	X	X	X				
<b>Patient Reported Outcomes<sup>u</sup></b>																										
HAT-QoL (short-form)	X						X						X										X			



Procedure	Screening Visit <sup>a</sup>		Maintenance Phase																	Extension Phase			Withdrawal Assessments, <sup>y</sup> (Maintenance)	Withdrawal Assessments (Extension)	Long-Term Follow-up <sup>z</sup>		
	Day 1	Week 4A (Oral Lead-in Only) <sup>b</sup>	Week																								
			Week 4B	8	12	16	20	24	28	32	36	40	44	48	52	Q4W 56-92	Q8W 56-92	96	100	Q4W After Week 100	Q8W After Week 96	152					
HIV TSQs	X							X																X	X		
HIV TSQc <sup>v</sup>																									X		
ACCEPT	X							X																X	X		
Reason for Switch or Reason for continuation <sup>w</sup>	X																										
Preference Questionnaires <sup>x</sup>																								X	X		
PIN				X				X																X	X		

Safety Follow Up Visit (for subjects completing the study, may or may not be transitioning to CAB + RPV LA marketed product) and Safety Follow Up Visit (for subjects withdrawing from the study) are required as described in Section 5.6.

- a. Complete all Screening assessments within 35 days. Participants may begin the Maintenance Phase as soon as all Screening assessments are complete. Participants may be rescreened once and will be assigned a new participant number. Participants transitioning from the 201585 (ATLAS) study must reach ATLAS Week 48 (at minimum) prior to initiating Screening procedures for ATLAS-2M and must reach ATLAS Week 52 (at minimum) prior to randomization in ATLAS-2M.
- b. Visits Week 4a is part of the CAB + RPV Oral Lead-in period and is required only for participants transitioning from current SOC to CAB LA + RPV LA.
- c. Confirmation of eligibility to continue the Maintenance Phase and eligibility to enter the Extension Phase.
- d. Collect full routine medical history plus (report at Baseline visit): HIV risk factors (may be collected at a later study visit), cardiovascular risk factors (assessments include smoking status and history, family history of cardiac events), recent [□6 months] illicit drug use, intravenous drug use, gastrointestinal disease, metabolic, psychiatric, renal, bone, and neurological disorders.

- e. Physical exams should be conducted as part of normal routine clinical care. Medical assessments include any decisions the study staff must make for participants management and/or care of participant.
- f. Height collected at Baseline Day 1 only.
- g. Measure vital signs after about 5 minutes of rest in a semi-supine position.
- h. A 12-lead ECG will be performed after resting in a semi-supine position for at least 5 minutes. ECGs will be performed pre-dose. For participants transitioning from ATLAS, the pre-dose Week 48 ECG can also serve as the ATLAS-2M Screening ECG. ECG pre-dose will be performed in triplicate at Day 1. A 2-hour post-dose ECG will also be performed at Days 1 and Week 48 for participants receiving CAB LA + RPV LA with an allowable window of  $\pm 30$  minutes.
- i. Only SAEs related to study participation or to a concomitantly administered ViiV/GSK product will be collected between obtaining informed consent and administration of study drug at Day 1.
- j. On Day 1, the eC-SSRS is to be administered prior to randomization. The eC-SSRS will preferably be completed at the beginning of the visit following administration of other PROs required prior to injections. The eC-SSRS is not required during the Withdrawal visit if withdrawal occurs during the Extension Phase.
- k. Women of childbearing potential only. SR=serum, UR=urine. Pregnancy events will be captured starting at Day 1 following initial exposure to study drug. Urine pregnancy test performed at Day 1 prior to administration of study drug, at Week 4b, and at study visits when other blood draws are not required in order to limit needle sticks. Serum pregnancy test can substitute for urine pregnancy test if locally required but must be appropriately timed to confirm pregnancy status prior to randomization and first IM administration. Pregnant participants who remain in the study do not need pregnancy testing during the study, for the duration of their pregnancy. Pregnant participants remaining in the study have additional assessments required, as described in [Appendix 11](#).
- l. Week 48, Week 96, and Week 152 HIV-1 RNA retest (within 4 weeks) for results  $> 50$  c/mL will be captured as unscheduled visit. Plasma for storage samples will be used for possible future analyses.
- m. A morning specimen is preferred. To assess biomarkers: urine albumin/creatinine ratio; urine protein/creatinine ratio; and urine phosphate. Urine phosphate results from visit 4a are not required by protocol to inform the safety review at visit 4b prior to receipt of initial CAB LA + RPV LA injections.
- n. An overnight fast is preferred; however, a minimum of a 6-hour fast is acceptable.
- o. Only collect if the Withdrawal visit occurs at Week 48, Week 96, or Week 152.
- p. Whole blood/PBMC collection samples may be used for virologic analyses. PBMCs will be collected at baseline Day 1, Week 48, Week 96, Week 152 or Withdrawal if prior to Week 152.
- q. Genetics sample should be collected only for patients who did not participate in the 201585(ATLAS) study (sample was previously collected and stored). Informed consent for genetic research must be obtained before sample collection. Sample may be collected at any visit after signing informed consent, but preferably at the Day 1 visit.
- r. One blood sample for CAB and RPV each to be collected at each PK timepoint. At Day 1, for participants from the ATLAS Q4W arm, PK samples are to be collected pre-dose relative to IM administration. At Week 4b, for participants randomized from SOC, Pre dose PK samples are to be collected: AFTER review of the PK diary to ensure that the samples are taken 20/28 hours after previous oral dose (diaries to be given at Day 1 or W4a); PRIOR to the final oral dose of CAB + RPV; PRIOR to the first IM injection. Trough plasma PK samples of CAB and RPV will be obtained for every pregnant woman at every study visit during the pregnancy for both Q4W and Q8W regimens. See [Appendix 11](#).
- s. Only for Participants entering CAB + RPV Oral Treatment
- t. Participants switching to CAB LA + RPV LA will take final dose of oral lead-in regimen in the clinic at the Week 4b visit and begin injections. If possible, injections should be spaced approximately 2 cm from one another and from the site of any previous injection and or any injection site reaction. Bring RPV

- LA to approximately room temperature prior to injecting. Time and location of injection (right or left) as well as needle length used will be collected in the eCRF. The first injection can be performed as soon as central lab results become available and safety parameters are reviewed.
- u. All Patient Report Questionnaires/Surveys will be administered via paper instrument (in exceptional circumstances the questionnaires could be completed via telephonic interview, please refer to COVID19 appendix for additional details) at the beginning of the visit before any other assessments are conducted and prior to administration of the eC-CSSRS. During the Maintenance phase conduct questionnaires/surveys (HAT-QoL, HIV TSQs, HIV TSQc, ACCEPT, PIN and Preference) at W48 or upon Withdrawal only if occurring at or prior to Week 48. During the Extension phase conduct questionnaires/surveys (HIV TSQs, ACCEPT, “Reason for Oral Bridging and Preference questionnaire ” and PIN) at W152 or upon Withdrawal only if occurring at or prior to Week 152
  - v. The HIV-TSQc is to be administered to all participants transitioning from ATLAS and new participants transitioning from oral SOC. For participants transitioning from ATLAS, the version of the HIV-TSQc instrument to be administered will be based on the initial randomization arm at ATLAS Day 1.
  - w. For patients randomized to oral SOC at Day 1 in ATLAS or new patients on SOC, the reasons for willingness to switch ART will be assessed at Day 1. For patients randomized to CAB LA + RPV LA Q4W in ATLAS, the reasons for willingness to continue long-acting ART in ATLAS-2M will be assessed at Day 1.
  - x. During Maintenance phase Preference Questionnaire (injection to injection/oral to injection) will be administered to all participants at W48 or upon WD if at or prior to W48. “Reason for Oral Bridging and Preference questionnaire ” questionnaire at Week 152 or upon WD visit if occurred at or before Week 152, will be administered only to participants who received oral bridging during the Maintenance and/or Extension Phases.
  - y. Refer to Section 5.5 of the protocol for additional information on performing withdrawal assessments. HIV-1 RNA will be collected as Storage sample only if withdrawal assessments coincide with Week 52 Week 100 or Week 156 (as per Section 5.5)
  - z. Participants receiving one or more injections with CAB LA and/or RPV LA will be assessed with clinic visits at months 3, 6, 9 and 12 during the Long-Term Follow-Up Phase
  - aa. After discussion of risk/benefit, a pregnancy specific ICF addendum must be signed by pregnant participants who wish to remain in the study

Note: BP – Blood pressure, HR – Heart Rate, HDL – High Density Lipoprotein, LDL – Low Density Lipoprotein, PT Prothrombin Time, PTT Partial Thromboplastin Time, INR International normalized ratio



Procedure	Screening Visit <sup>a</sup>	Maintenance Phase																		Extension Phase		Withdrawal Assessments <sup>y</sup> (Maintenance)	WD assessments (Extension)	Long-Term Follow-up <sup>z</sup>
		Day 1	Week																	Q8W After Week 96	152			
			Week 4A (Oral lead-in ONLY) <sup>b</sup>	Week 4B (Oral lead-in ONLY) <sup>b</sup>	8	9	16	24	32	40	41	48	56	64	72	80	88	96	100					
12-lead ECG <sup>h</sup> (triplicate at Day 1 pre-dose)	X	X										X									X		X	
CDC HIV-1 stage	X	X																						
HIV Associated Conditions		X	X	X	X	X	X	X	X	X	X	X	X	X	X	X	X	X	X	X	X	X	X	X
AEs, SAEs, device deficiency, Concomitant Medications	X <sup>i</sup>	X	X	X	X	X	X	X	X	X	X	X	X	X	X	X	X	X	X	X	X	X	X	X
ISR Assessment for IM injection		X		X	X	X	X	X	X	X	X	X	X	X	X	X	X	X	X	X	X	X	X	X
Columbia Suicide Severity Rating Scale (eC-SSRS) <sup>j</sup>	X	X		X	X		X	X	X	X		X	X	X	X	X	X					X		
Clinical chemistry and Hematology	X	X	X	X	X		X	X	X	X		X	X	X	X	X	X	X	X	X	X	X	X	X
Pregnancy Testing <sup>k</sup>	S	U	S	U	S		S	S	S	S		S	S	S	S	S	S	S	S	S	S	S	S	S
HIV-1 RNA and sample for storage (S) <sup>l</sup>	X	X		X	X		X	X	X	X		X	X	X	X	X	X	X	S	X	X	X	X	X
CD4+ cell count	X	X		X	X		X	X	X	X		X	X	X	X	X	X	X	X	X	X	X	X	X
CD8+ cell count		X						X				X									X	X		
Urinalysis <sup>m</sup>		X	X					X				X									X	X		
Fasting Labs Glucose, Cholesterol (Total, HDL and LDL) and Triglycerides <sup>n</sup>		X										X									X	X <sup>o</sup>		



Procedure	Screening Visit <sup>a</sup>	Maintenance Phase																		Extension Phase		Withdrawal Assessments <sup>y</sup> (Maintenance)	WD assessments (Extension)	Long-Term Follow-up <sup>z</sup>
		Day 1	Week																	Q8W After Week 96	152			
			Week 4A (Oral lead-in ONLY) <sup>b</sup>	Week 4B (Oral lead-in ONLY) <sup>b</sup>	8	9	16	24	32	40	41	48	56	64	72	80	88	96	100					
IM treatment administration when transitioning from CAB + RPV Q4W	X			X		X	X	X	X		X	X	X	X	X	X	X		X	X				
<b>Patient Reported Outcomes <sup>u</sup></b>																								
HAT-QoL (short-form)	X						X				X											X		
HIV TSQs	X						X				X									X		X		
HIV TSQc <sup>v</sup>											X											X		
ACCEPT	X							X			X									X		X		
Reason for Switch or Reason for continuation <sup>w</sup>	X																							
Preference Questionnaires <sup>x</sup>											X										X		X	
PIN					X			X			X										X		X	
Safety Follow Up Visit (for subjects completing the study, may or may not be transitioning to CAB + RPV LA marketed product) and Safety Follow Up Visit (for subjects withdrawing from the study) are required as described in Section 5.6.																								

bb. Complete all Screening assessments within 35 days. Participants may begin the Maintenance Phase as soon as all Screening assessments are complete. Participants may be rescreened once and will be assigned a new participant number. Participants transitioning from the 201585 (ATLAS) study must reach ATLAS Week 48 (at minimum) prior to initiating Screening procedures for ATLAS-2M and must reach ATLAS Week 52 (at minimum) prior to randomization in ATLAS-2M.

- cc. Visits Weeks 4A and 4B are part of the CAB + RPV Oral Lead-in period and are required only for participants transitioning from current SOC to CAB LA + RPV LA.
- dd. Confirmation of eligibility to continue the Maintenance Phase, and eligibility to enter the Extension Phase.
- ee. Collect full routine medical history plus (report at Baseline visit): HIV risk factors (may be collected at a later study visit), cardiovascular risk factors (assessments include smoking status and history, family history of cardiac events), recent [ $\leq 6$  months] illicit drug use, intravenous drug use, gastrointestinal disease, metabolic, psychiatric, renal, bone, and neurologic disorders.
- ff. Physical exams should be conducted as part of normal routine clinical care. Medical assessments include any decisions the study staff must make for participants management and/or care of participant.
- gg. Height collected at Baseline Day 1 only.
- hh. Measure vital signs after about 5 minutes of rest in a semi-supine position.
- ii. A 12-lead ECG will be performed after resting in a semi-supine position for at least 5 minutes. ECGs will be performed pre-dose. For participants transitioning from ATLAS, the pre-dose Week 48 ECG can also serve as the ATLAS-2M Screening ECG. ECG pre-dose will be performed in triplicate at Day 1. A 2-hour post-dose ECG will also be performed at Days 1 and Week 48 for participants receiving CAB LA + RPV LA with an allowable window of  $\pm 30$  minutes.
- jj. Only SAEs related to study participation or to a concomitantly administered ViiV/GSK product will be collected between obtaining informed consent and administration of study drug at Day 1.
- kk. On Day 1, the eC-SSRS is to be administered prior to randomization. The eC-SSRS will preferably be completed at the beginning of the visit following administration of other PROs required prior to injections. The eC-SSRS is not required during the Withdrawal visit if withdrawal occurs during the Extension Phase.
- ll. Women of childbearing potential only. SR=serum, UR=urine. Pregnancy events will be captured starting at Day 1 following initial exposure to study drug. Serum pregnancy test can substitute for urine pregnancy test if locally required but must be appropriately timed to confirm pregnancy status prior to randomization and first IM administration. Pregnant participants who remain in the study do not need pregnancy testing during the study, for the duration of their pregnancy. Pregnant participants remaining in the study have additional assessments required, as described in [Appendix 11](#).
- mm. Week 48, Week 96, and Week 152 HIV-1 RNA retest (within 4 weeks) for results  $> 50$  c/mL will be captured as unscheduled visit. Plasma for storage samples will be used for possible future analyses.
- nn. A morning specimen is preferred. To assess biomarkers: urine albumin/creatinine ratio; urine protein/creatinine ratio; and urine phosphate. Urine phosphate results from visit 4a are not required by protocol to inform the safety review at visit 4b prior to receipt of initial CAB LA + RPV LA injections.
- oo. An overnight fast is preferred; however, a minimum of a 6-hour fast is acceptable.
- pp. Only collect if the Withdrawal visit occurs at Week 48, Week 96, or Week 152.
- qq. Whole blood/PBMC collection samples may be used for virologic analyses. PBMCs will be collected at baseline Day 1, Week 48, Week 96, Week 152, or Withdrawal if prior to Week 152.
- rr. Genetics sample should be collected only for patients who did not participate in the 201585(ATLAS) study (sample was previously collected and stored). Informed consent for genetic research must be obtained before sample collection. Sample may be collected at any visit after signing informed consent, but preferably at the Day 1 visit.



- ss. One blood sample for CAB and RPV each to be collected at each PK timepoint. At Day 1, for participant from the ATLAS Q4W arm, PK samples are to be collected pre-dose relative to IM administration. injection. At Week 4b, for participants randomized from SOC, Pre dose PK samples are to be collected: AFTER review of the PK diary to ensure that the samples are taken 20/28 hours after previous oral dose (diaries to be given at Day 1 or W4a); PRIOR to the final oral dose of CAB + RPV; and PRIOR to the first IM injection. At Week 9 and 41, the PK samples should be collected 3 to 10 days after the Week 8 and Week 40 visits, respectively. Trough plasma PK samples of CAB and RPV will be obtained for every pregnant woman at every study visit during the pregnancy for both Q4W and Q8W regimens. See [Appendix 11](#).
- tt. Only for Participants entering CAB + RPV Oral Treatment
- uu. Participants switching to CAB LA + RPV LA will take final dose of oral lead-in regimen in the clinic at the Week 4b visit and begin injections. If possible, injections should be spaced approximately 2 cm from one another and from the site of any previous injection and or any injection site reaction. Bring RPV LA to approximately room temperature prior to injecting. Time and location of injection (right or left) as well as needle length used will be collected in the eCRF. The first injection can be performed as soon as central lab results become available and safety parameters are reviewed.
- vv. All Patient Report Questionnaires/Surveys will be administered via paper instrument at the beginning of the visit before any other assessments are conducted and prior to administration of the eC-CSSRS (in exceptional circumstances, the questionnaires could be completed via telephonic interview, please refer to COVID19 appendix for additional details) . During the Maintenance phase, conduct questionnaires/surveys (HAT-QoL, HIV TSQs, HIV TSQc, ACCEPT, PIN, and Preference) at W48 or upon Withdrawal only if occurring at or prior to Week 48. During the Extension phase, conduct questionnaires/surveys (HIV TSQs, ACCEPT, “Preference and Reason for OB” and PIN) at W152 or upon Withdrawal only if occurring at or prior to Week 152
- ww. The HIVTSQc is to be administered to all participants transitioning from ATLAS and new participants transitioning from oral SOC. For participants transitioning from ATLAS, the version of the HIV-TSQc instrument to be administered will be based on the initial randomization arm at ATLAS Day 1
- xx. For patients randomized to oral SOC at Day 1 in ATLAS or new patients on SOC, the reasons for willingness to switch ART will be assessed at Day 1. For patients randomized to CAB LA + RPV LA Q4W in ATLAS, the reasons for willingness to continue long-acting ART in ATLAS-2M will be assessed at Day 1.
- yy. During Maintenance phase Preference Questionnaire (injection to injection/oral to injection) will be administered to all participants at W48 or upon WD if prior to W48. “Preference and Reason for OB” questionnaire at Week 152 or upon WD visit if occurred at or before Week 152, will be administered only to participants who received oral bridging during the Maintenance and/or Extension Phases.
- zz. Refer to Section 5.5 of the protocol for additional information on performing withdrawal assessments. HIV-1 RNA will be collected as Storage sample only if withdrawal assessments coincide with Week 52 or Week 100 (as per Section 5.5)
- aaa. Participants receiving one or more injections with CAB LA and/or RPV LA will be assessed with clinic visits at months 3, 6, 9 and 12 during the Long-Term Follow-Up Phase
- bbb. After discussion of risk/benefit, a pregnancy specific ICF addendum must be signed by pregnant participants who wish to remain in the study

Note: BP – Blood pressure, HR – Heart Rate, HDL – High Density Lipoprotein, LDL – Low Density Lipoprotein, PT Prothrombin Time, PTT Partial Thromboplastin Time, INR International normalized ratio

## 7.2. Screening and Critical Baseline Assessments

Written informed consent must be obtained from each potentially eligible participant by study site personnel prior to the initiation of any Screening procedures as outlined in this protocol. The consent form must have been approved by the Institutional Review Board (IRB)/Independent Ethics Committee (IEC). After signing an informed consent, participants will complete Screening assessments to determine participant eligibility. Each participant being screened for study enrolment evaluation will be assigned a participant number at the Screening visit. This number will be given sequentially in chronological order of participant presentation according to a numeric roster provided by GSK.

### 7.2.1. Screening Assessments

Eligibility criteria must be carefully assessed at the Screening visit. Physical examinations should be conducted as part of normal routine clinical care. Background information to be collected at Screening includes demography and prior ART history.

Eligible participants may be randomly assigned immediately as soon as all Screening assessments are complete and the results are available and documented. All participants will complete the screening period of approximately 14 days prior to Baseline (Day 1) during which all clinical and laboratory assessments of eligibility must be performed and reviewed. The Screening period may be extended to 35 days to accommodate availability of all Screening assessment results, completion of source document verification to satisfy the Inclusion and Exclusion Criteria, and scheduling. All Screening results **must** be available prior to randomization.

**All information about the participant's current regimen must be available for review by the Principal Investigator or designee prior to randomization. Source documents from other medical facilities must be located/received during the 14 day (up to 35 days) screening period and under no circumstances may the participant be randomized in the absence of source documentation even if there are delays in receipt of this information.**

Any available prior genotypic resistance testing must be provided to GSK, after screening and before randomization according to guidance in the SPM, to provide direct evidence of no pre-existing exclusionary resistance mutations. The lack of exclusionary resistance mutations must be confirmed by the study virologist, which will be provided before the screening window closes. Details on use of RAMOS for tracking historic resistance report availability and submission to ViiV Healthcare Virology for evaluation are described in the SPM. Details regarding baseline or prior resistance data must be noted in the source documentation.

Participants infected with HBV will not be enrolled in the study. Evidence of HBV infection is based on the results of testing at Screening for hepatitis B surface antigen (HBsAg), hepatitis B core antibody (anti-HBc), hepatitis B surface antibody (anti-HBs), and HBV DNA. HBV DNA will only be performed for participants with positive anti-HBc and negative HBsAg and negative anti-HBs (past and/or current evidence).

Participants with an anticipated need for HCV therapy during the study must not be enrolled into this study, as HCV therapy currently includes the prohibited medication interferon. The length of this study should be considered when assessing the potential need for therapy.

All participants will be screened for syphilis. Participants with untreated syphilis infection, defined as a positive RPR without clear documentation of treatment, are excluded. Participants with a serofast RPR result despite history of adequate therapy and no evidence of re-exposure may enrol after consultation with the Medical Monitor. Participants with a positive RPR test who have not been treated may be rescreened at least 30 days after completion of antibiotic treatment for syphilis.

The eCSSRS (see Section 7.4.6) assessed at the Screening visit will assess the participant's lifetime risk (any suicidal ideation, behavior, etc. occurring over the participant's lifetime). A positive alert (indicating some risk) is not necessarily exclusionary, rather a means to assess overall risk.

Participants who meet all entry criteria are randomized and assigned a randomization number. A single repeat of a procedure/lab parameter is allowed to determine eligibility (unless otherwise specified). Participants not meeting all inclusion and exclusion criteria at initial screen may be rescreened and receive a new participant number one time unless they were excluded for reason of having exclusionary historic genotypic resistance. Participants who are randomized into the trial and subsequently withdrawn from the study for any reason may not be rescreened.

### **7.2.2. Baseline Assessments**

At Day 1 and prior to randomization, any changes to the eligibility parameters must be assessed and any results required prior to randomization (e.g., Day 1 urine pregnancy test for women of childbearing potential) must be available and reviewed. The following demographic parameters will be captured: year of birth, sex, race and ethnicity. Medical/medication/family history will be assessed as related to the inclusion/exclusion criteria listed in Section 5.

HIV-1 genotypic resistance testing and plasma HIV-1 RNA measurement results from Screening must be available prior to the Baseline visit.

Baseline information to be collected at Day 1 includes general medical history and current medical conditions. Laboratory and health outcomes assessments will also be assessed. Questionnaire/surveys are recommended to be administered at the beginning of the visit before any other assessments are conducted, in the order specified. For participants who agree to the optional assessment, a whole blood sample for genetic research should be collected at Day 1 (if not already collected during participation in the ATLAS study).

In addition to a full routine medical history at Baseline, more detailed information will be collected for some disease processes such as:

- Cardiovascular medical history/risk factors (as detailed in the eCRF) will be assessed at Baseline and assessments will include height, weight, blood pressure, smoking status and history, pertinent medical conditions (e.g., hypertension, diabetes mellitus), and family history of premature cardiovascular disease. In addition, medical history/risk factors for renal disease such as nephropathy, renal failure, and nephrolithiasis will be assessed.
- history of illicit drug use [e.g., cocaine, heroin, and methamphetamine use];
- intravenous drug use history;
- gastrointestinal disease (e.g., GI bleeding, PUD, etc.);
- metabolic (e.g., Type I or II diabetes mellitus);
- psychiatric (e.g., depression);
- renal (e.g., nephrolithiasis, nephropathy, renal failure); and,
- neurologic disorders

Procedures conducted as part of the participant's routine clinical management [e.g., laboratory assessments] and obtained prior to signing of informed consent may be utilized for Screening or baseline purposes provided the procedure meets the protocol-defined criteria and has been performed in the timeframe of the study. Where possible local lab results should be confirmed by submission of samples to the central lab.

### **7.3. Efficacy**

#### **7.3.1. Plasma HIV-1 RNA**

Plasma for quantitative HIV-1 RNA will be collected according to the Time and Events schedule (Section 7.1). Methods to be used may include but are not limited to the Abbott RealTime HIV-1 Assay lower limit of detection (LLOD) 40 c/mL. In some cases, (e.g., where the HIV-1 RNA is below the lower limit of detection for a given assay) additional exploratory methods will be used to further characterize HIV-1 RNA levels.

#### **7.3.2. Lymphocyte Subsets, CD4+ and CD8+**

Lymphocyte subsets will be collected for assessment by flow cytometry (total lymphocyte counts, percentage and absolute CD4+ and CD8+ lymphocyte counts, ratios) according to Time and Events schedule (Section 7.1) and Laboratory Assessments (Section 7.4.2).

#### **7.3.3. HIV Associated Conditions**

HIV-associated conditions will be recorded as per Time and Events schedule (Section 7.1). HIV-associated conditions will be assessed according to the 2014 CDC Revised Classification System for HIV Infection (see Section 11.4).

## 7.4. Safety

### 7.4.1. Clinical Evaluations

The following clinical evaluations will be performed according to the Time and Events schedule:

- Monitoring and recording of all AEs and SAEs. Additional information on the Time Period and Frequency of Detecting AEs and SAEs is provided in Section 7.4.3.1.
- Physical exams should be conducted as part of normal routine clinical care. Abnormalities noted during any exam must be recorded in the eCRF (e.g., in the current medical conditions or AE logs).
- Height and weight will be measured and recorded. Height collected on the Day 1 (Baseline) only.
- Vital signs will include systolic and diastolic blood pressure and heart rate collected after resting for about 5 minutes. Temperature will also be collected.
- Past medical history, family history, social history, medication history. Targeted history on cardiovascular risk (smoking history, family and personal history).
- HIV-associated conditions will be recorded.
- Electrocardiogram: A 12-lead ECG will be performed in a semi-supine position after 5 minutes of rest. On Day 1 (Baseline) of the Maintenance Phase, ECGs should be performed in triplicate prior to first dose. An ECG machine that automatically calculates the heart rate and measures PR, QRS, QT, and QTc intervals is preferred, and these calculated numbers can be used for reporting purposes. Otherwise, an appropriately qualified ECG reader must interpret the results. The same interpreter should assess all ECGs for each participant for the site. Regardless, each ECG should be reviewed by a qualified ECG reader. The qualified ECG reader will make the non-calculated ECG interpretations. The same QT correction formula must be used for each individual participant to determine eligibility for and discontinuation from the study. This formula may not be changed or substituted once the participant has been enrolled.
- Regular monitoring of hematology, blood chemistry, urinalysis and fasting glucose and lipids (parameters to be tested listed below).
- Periodic assessment of glucose, insulin, and bone, cardiovascular, and renal markers;
- Pregnancy testing. A negative urine pregnancy test is required prior to initiation of IP, any dose of CAB LA or RPV LA or as required by the Medical Monitor following a treatment interruption(s). If serum testing is required locally, the results should be available prior to the visit where urine testing is indicated per the Time and Events Schedule (Section 7.1).
  - Participants who are enrolled in the study and have a positive pregnancy test during the course of the study, will be allowed to remain in the study,

provided a pregnancy specific ICF addendum is signed by the participant. No IP can be continued (oral or LA) in any pregnant participant until the benefit/risk assessment is discussed with the participant and the pregnancy specific ICF addendum has been signed. See details in [Appendix 11](#).

- Pregnant participants who remain in the study do not need pregnancy testing during the study, for the duration of their pregnancy.
- Evaluation and documentation of all concomitant medications and blood products.
- Injection Site Reactions (ISRs) will be assessed clinically during the Maintenance and Extension Phases for the following:  
Pain, tenderness, pruritis, warmth, bruising, discoloration, infections, rash, erythema, swelling, induration, and nodules (granulomas or cysts).
- A clinical assessment (using Division of Acquired Immunodeficiency Syndrome [DAIDS] grading scale) should be performed both before and after an injection to identify resolving and new ISRs. All injection site reactions are considered adverse events. The clinical assessment and interpretation of any ISR, will be documented in the ISR AE eCRF.
- Columbia Suicide Severity Rating Scale (eC-SSRS) will be assessed as per the Time and Events Schedule (see Section [7.1](#) and Suicidal Risk Monitoring Section [7.4.6](#)).

Any appropriately qualified site personnel (e.g., Investigator, sub-Investigator, or study coordinator/nurse) can perform assessments.

#### **7.4.2. Laboratory Assessments**

All protocol required laboratory assessments, as defined in the Time and Events Schedule (see Section [7.1](#)), must be performed by the central laboratory. Laboratory assessments must be conducted in accordance with the Central Laboratory Manual and Protocol Time and Events Schedule. Laboratory requisition forms must be completed and samples must be clearly labeled with the participant number, protocol number, site/centre number, and visit date. Details for the preparation and shipment of samples will be provided by the central laboratory. Reference ranges for all safety parameters will be provided to the site by the central laboratory.

- The investigator must review the laboratory report, document this review, and record any clinically relevant changes occurring during the study in the AE section of the CRF. The laboratory reports must be filed with the source documents. Clinically significant abnormal laboratory findings are those which are not associated with the underlying disease, unless judged by the investigator to be more severe than expected for the participant's condition.
- All laboratory tests with values considered clinically significantly abnormal during participation in the study should be repeated until the values return to normal or baseline or are no longer considered significantly abnormal by the investigator or medical monitor.

- If such values do not return to normal/baseline within a period of time judged reasonable by the investigator, the etiology should be identified and the sponsor notified.
- All protocol-required laboratory assessments, must be conducted in accordance with the laboratory manual and the protocol Time and Events table.

If additional non-protocol specified laboratory assessments are performed at the institution's local laboratory and result in a change in subject management or are considered clinically significant by the investigator (e.g., SAE or AE or dose modification) the results must be recorded in the eCRF. Local laboratory services may be used to verify pending laboratory parameters only after consultation and agreement with the study team.

Refer to the lab manual for appropriate processing and handling of samples to avoid duplicate and/or additional blood draws.

Labs will be automatically graded by the central lab according to the DAIDS toxicity scales (See Section 11.2 "Division of AIDS Table for Grading the Severity of Adult and Pediatric Adverse Events").

For fasting laboratory assessments, an overnight fast is preferred; however, a minimum of a 6 hour fast is acceptable.

Table 8 includes lab parameters to be assessed as per the Time and Events Schedule (see Section 7.1). In addition to the protocol-specified laboratory assessments the study Medical Monitor, in collaboration with the site investigator, may request additional central laboratory assessments be performed to support safety profiling and case management of individual study participants.

**Table 8 Safety Laboratory Assessments**

<b>Hematology</b>			
Platelet count	Automated WBC differential:		
RBC count	Neutrophils		
WBC count (absolute)	Lymphocytes		
Hemoglobin	Monocytes		
Hematocrit	Eosinophils		
MCV	Basophils		
<b>Clinical Chemistry</b>			
BUN	Potassium	AST	Total bilirubin <sup>a</sup>
Creatinine	Chloride	ALT	Albumin
Glucose <sup>c</sup>	Total CO <sub>2</sub>	Alkaline phosphatase	Creatine phosphokinase
Sodium	Lipase	Phosphate	Creatinine clearance <sup>b</sup>
<b>Fasting Lipid Panel<sup>d</sup></b>			
Total cholesterol			
HDL cholesterol			
LDL cholesterol			
Triglycerides			
<b>Other Tests</b>			
Plasma HIV-1 RNA <sup>e</sup>			
CD4+ and CD8+ cell counts [CD4/CD8 ratio] <sup>f</sup>			
Peripheral Blood Mononuclear Cells (PBMCs): Day 1, Week 48, Week 96, Week 152 Withdrawal only			
Hepatitis B (HBsAg), anti-HBc, anti-HBsAg, and hepatitis C antibody (Screening) <sup>g</sup>			
Syphilis serology + Reflex Rapid Plasma Reagin (RPR) (Screening and Baseline)			
Prothrombin Time (PT)/International Normalized Ratio (INR)/ Partial Thromboplastin Time (PTT)			
Pregnancy test for women of childbearing potential <sup>h</sup>			
Urinalysis, urine albumin/creatinine ratio, and urine protein/creatinine ratio, urine phosphate			
Genetics Sample			
Follicle stimulating hormone (FSH) and estradiol (only for instances when postmenopausal status is questionable)			

MCV = mean corpuscular volume, RBC = red blood cells, WBC = white blood cells, BUN = Blood urea nitrogen, AST=aspartate aminotransferase, ALT = alanine aminotransferase, CO<sub>2</sub> = carbon dioxide, HDL = high density lipoprotein, LDL = low density lipoprotein, HBsAg= hepatitis B virus surface antigen, PT/INR = prothrombin time/international normalized ratio.

- Direct bilirubin will be reflexively performed for all total bilirubin values  $>1.5 \times \text{ULN}$ .
- Glomerular filtration rate (GFR) will be estimated by the central laboratory using the Chronic Kidney Disease Epidemiology Collaboration (CKD-EPI) [Levey, 2009].
- For fasting glucose assessments, an overnight fast is preferred; however, a minimum of a 6-hour fast is acceptable for participants with afternoon appointments.
- For fasting lipids assessments, an overnight fast is preferred; however, a minimum of a 6-hour fast is acceptable for participants with afternoon appointments.
- For participants meeting virologic withdrawal criteria, plasma samples will be analyzed in attempt to obtain genotype/phenotype data.
- CD8+ cells will only be reported at Baseline, Day 1, Weeks 4b, 24, 48, 96 and 152.
- HBV DNA will only be performed for participants with a positive anti-HBc and negative HBsAg and negative anti-HBs (past and/or current evidence).
- Urine pregnancy test/ serum pregnancy test will be performed according to the Time and Events Table (Section 7.1).



### 7.4.3. Adverse Events (AE) and Serious Adverse Events (SAEs)

The investigator and their designees are responsible for detecting, documenting and reporting events that meet the definition of an AE or SAE.

Please refer to [Appendix 10](#) in Section [11.10](#) for study management information during the COVID-19 pandemic.

Reporting for medical device deficiencies are covered in Section [11.2](#)

#### 7.4.3.1. Time period and Frequency for collecting AE and SAE information

- Any SAEs assessed as related to study participation (e.g., protocol-mandated procedures, invasive tests, or change in existing therapy) or related to a GSK product will be recorded from the time a participant consents to participate in the study up to and including any follow-up contact.
- All SAEs will be recorded and reported to the sponsor or designee immediately and under no circumstance should this exceed 24 hours. The investigator will submit any updated SAE data to the sponsor within 24 hours of it being available.
- AEs will be collected from the start of Study Treatment until the final follow-up contact, at the timepoints specified in the Time and Events Table (Section [7.1](#)).
- All AEs and SAEs associated with medical device deficiencies for associated person (iespouse, caregiver, site staff...) will be collected. The associated person will be provided with a safety reporting information and authorization letter.
- Medical occurrences that begin prior to the start of study treatment but after obtaining informed consent may be recorded on the Medical History/Current Medical Conditions section of the eCRF.
- The method of recording, evaluating and assessing causality of AEs and SAEs plus procedures for completing and transmitting SAE reports to GSK are provided in Section [11.6](#), [Appendix 6](#)
- Investigators are not obligated to actively seek AEs or SAEs in former study participants. However, if the investigator learns of any SAE, including a death, at any time after a participant has been discharged from the study, and he/she considers the event reasonably related to the study treatment or study participation, the investigator must promptly notify GSK.

#### 7.4.3.2. Method of Detecting AEs and SAEs

Care will be taken not to introduce bias when detecting AEs and/or SAEs. Open-ended and non-leading verbal questioning of the participant is the preferred method to inquire about AE occurrence. Appropriate questions include:

- “How are you feeling?”
- “Have you had any (other) medical problems since your last visit/contact?”

- “Have you taken any new medicines, other than those provided in this study, since your last visit/contact?”

#### **7.4.3.3. Follow-up of AEs and SAEs**

After the initial AE/SAE report, the investigator is required to proactively follow each participant at subsequent visits/contacts. All SAEs, and non-serious AEs of special interest (as defined in Section 7.4.5) will be followed until resolution, until the condition stabilizes, until the event is otherwise explained, or until the participant is lost to follow-up (as defined in Section 5.5). Further information on follow-up procedures is given in Section 11.6, Appendix 6).

#### **7.4.3.4. Prompt Reporting of Serious Adverse Events and Other Events**

SAEs, pregnancies, and liver function abnormalities meeting pre-defined criteria will be reported promptly by the investigator to the medical monitor as described in Table 9 once the investigator determines that the event meets the protocol definition for that event. Any seizure or suspected seizure should be reported in an expedited manner, as noted in Table 9.

Criteria for liver chemistry stopping and follow-up criteria are in Section 5.5.1.

**Table 9 Reporting of Serious Adverse Events and Other Events**

Type of Event <sup>a</sup>	Initial Reports		Follow-up Information on a Previous Report	
	Time Frame	Documents	Time Frame	Documents
All SAEs	24 hours	"SAE" data collection tool	24 hours	Updated "SAE" data collection tool
Cardiovascular or death event	Initial and follow-up reports to be completed when the cardiovascular event or death is reported <sup>a</sup>	"CV events" and/or "death" data collection tool(s) if applicable	Initial and follow-up reports to be completed when the cardiovascular event or death is reported <sup>a</sup>	Updated "CV events" and/or "death" data collection tool(s) if applicable
Pregnancy	24 hours	"Pregnancy Notification Form"	Within 24 hours of investigator awareness of pregnancy outcome	"Pregnancy Follow-up Form" and SAE if required
Seizure or suspected seizure	24 hours	eCRF	24 hours	eCRF
Suspected ABC HSR in participants receiving Oral SOC during the Long-Term Follow-Up Phase <sup>b</sup>	1 week	ABC HSR eCRF	1 week	Updated ABC HSR eCRF
ALT $\geq$ 3 $\times$ ULN and bilirubin $\geq$ 2 $\times$ ULN (>35% direct) (or ALT $\geq$ 3 $\times$ ULN)	24 hours <sup>c</sup>	"SAE" data collection tool. "Liver Event eCRF" and "Liver Imaging" and/or "Liver Biopsy" eCRFs, if applicable <sup>d</sup>	24 hours	Updated "SAE" data collection tool/"Liver Event" documents <sup>d</sup>

Type of Event <sup>e</sup>	Initial Reports		Follow-up Information on a Previous Report	
	Time Frame	Documents	Time Frame	Documents
ALT ≥ 5 × ULN that persists ≥ 2 weeks	24 hours <sup>c</sup>	Liver Event eCRF <sup>d</sup>	24 hours	Updated Liver Event eCRF <sup>d</sup>
ALT ≥ 8 × ULN	24 hours <sup>c</sup>	Liver Event eCRF <sup>d</sup>	24 hours	Updated Liver Event eCRF <sup>d</sup>
ALT ≥ 3 × ULN (if baseline ALT is < ULN) or ALT ≥ 3 fold increase from baseline value with appearance or worsening of symptoms of hepatitis or hypersensitivity	24 hours <sup>c</sup>	Liver Event eCRF <sup>d</sup>	24 hours	Updated Liver Event eCRF <sup>d</sup>

- Additional details and time frames for reporting supplementary information for cardiovascular and death events are provided in Section 7.4.3.7 and Section 7.4.3.8, respectively.
- ABC HSR eCRF only required if event meets one of the ICH E2A definitions of seriousness.
- GSK must be contacted at onset of liver chemistry elevations to discuss participant safety.
- Liver event documents (i.e., "Liver Event eCRF" and updates, "Liver Imaging eCRF" and/or "Liver Biopsy eCRF", as applicable) should be completed as soon as possible.
- Please refer to Section 11.12 (Appendix 12) for additional details around Medical Device Deficiencies reporting requirements.

### SAE reporting to GSK via electronic data collection tool

- Primary mechanism for reporting SAEs to GSK will be the electronic data collection tool.
- If the electronic system is unavailable for greater than 24 hours, the site will use the paper SAE data collection tool and fax it to the Medical Monitor.
- Site will enter the serious adverse event data into the electronic system as soon as it becomes available.
- After the study is completed at a given site, the electronic data collection tool (e.g., InForm system) will be taken off-line to prevent the entry of new data or changes to existing data.
- If a site receives a report of a new SAE from a study participant or receives updated data on a previously reported SAE after the electronic data collection tool has been taken off-line, the site can report this information on a paper SAE form or to the Medical Monitor by telephone.
- Contacts for SAE receipt can be found in the Study Reference Manual.
- The investigator will be required to confirm review of the SAE causality by ticking the 'reviewed' box at the bottom of the eCRF page within 72 hours of submission of the SAE.

The method of recording, evaluating, and follow-up of AEs and SAEs plus procedures for completing and transmitting SAE reports to the medical monitor are provided in the SPM. Procedures for post study AEs/SAEs are provided in the SPM. Primary and

secondary Medical Monitor/SAE contact information is provided in the Study Reference Manual .

#### **7.4.3.5. Disease-Related Events and/or Disease-Related Outcomes Not Qualifying as SAEs**

Disease related events (DREs) or outcomes listed in the CDC Classification System for HIV-1 Infections ([Appendix 4](#)) can be serious/life threatening and will be recorded on the HIV-Associated Conditions eCRF page if they occur. However, these individual events or outcomes, as well as any sign, symptom, diagnosis, illness, and/or clinical laboratory abnormality that can be linked to any of these events or outcomes are not reported to GSK as AEs and SAEs even though such event or outcome may meet the definition of an AE or SAE. However, if any of the following conditions applies, then the event must be recorded and reported as an AE or SAE (According to severity ):

- The investigator determines that the event or outcome qualifies as an SAE under part ‘other situations’ of the SAE definition (see [Section 11.6.2](#)), or
- The event is, in the investigator’s opinion, of greater intensity, frequency, or duration than expected for the individual participant, or
- The investigator considers that there is a reasonable possibility that the event was related to treatment with the investigational product, or
- Death occurring for any reason during a study, including death due to a disease-related event, will always be reported promptly.
- Lymphomas and invasive cervical carcinomas are excluded from this exemption; they must be reported as SAEs even if they are considered to be HIV-related.

**If any of the above conditions is met, then record the event on either the AE or SAE page (according to severity) in addition to the HIV Associated Conditions eCRF page. If it is categorized as an SAE, report promptly (i.e., expedited reporting, see [Section 7.4.3.4](#)) to GSK.**

#### **7.4.3.6. Regulatory Reporting Requirements for SAEs**

Prompt notification by the investigator to GSK of SAEs related to study treatment (even for non- interventional post-marketing studies) is essential so that legal obligations and ethical responsibilities towards the safety of participants and the safety of a product under clinical investigation are met.

The Sponsor has a legal responsibility to notify both the local regulatory authority and other regulatory agencies about the safety of a product under clinical investigation. GSK will comply with country specific regulatory requirements relating to safety reporting to the regulatory authority, Institutional Review Board (IRB)/Independent Ethics Committee (IEC) and investigators.

Investigator safety reports are prepared for suspected unexpected serious adverse reactions according to local regulatory requirements and GSK policy and are forwarded to investigators as necessary.

An investigator who receives an investigator safety report describing a SAE(s) or other specific safety information (e.g., summary or listing of SAEs) from GSK will file it with the IB and will notify the IRB/IEC, if appropriate according to local requirements.

#### **7.4.3.7. Cardiovascular and Death Events**

Investigators will be required to fill out the specific CV event page of the eCRF for the following AEs and SAEs:

- Myocardial infarction/unstable angina
- Congestive heart failure
- Arrhythmias
- Valvulopathy
- Pulmonary hypertension
- Cerebrovascular events/stroke and transient ischemic attack
- Peripheral arterial thromboembolism
- Deep venous thrombosis/pulmonary embolism
- Revascularisation

This information should be recorded in the specific cardiovascular eCRF within one week of when the AE/SAE(s) are first reported. The CV CRFs are presented as queries in response to reporting of certain CV MedDRA terms.

For any cardiovascular events detailed above, whether or not they are considered SAEs, and all deaths, specific Cardiovascular (CV) and Death sections of the eCRF will be required to be completed. These sections include questions regarding cardiovascular (including sudden cardiac death) and non-cardiovascular death.

The CV CRFs are presented as queries in response to reporting of certain CV MedDRA terms. The CV information should be recorded in the specific cardiovascular section of the eCRF within one week of receipt of a CV Event data query prompting its completion.

#### **7.4.3.8. Death Events**

The Death CRF is provided immediately after the occurrence or outcome of death is reported. Initial and follow-up reports regarding death must be completed within one week of when the death is reported.

In addition, all deaths will require a specific death data collection tool to be completed. The death data collection tool includes questions regarding cardiovascular (including sudden cardiac death) and noncardiovascular death.

### **7.4.3.9. Medical Device Deficiencies**

Medical devices (vial adaptor -where applicable-, syringe, and needles) are used in this study as the study intervention.. To fulfill regulatory reporting obligations worldwide, the investigator is responsible for the detecting and documentation of events meeting the definitions of device deficiency that occur during the study with such devices.

The definition of a medical device deficiency can be found in Section [11.2](#)

NOTE: Medical device deficiencies associated with an SAE will be reported together with an SAE form. AEs associated with a medical device deficiency must be documented in the eCRF.

#### **7.4.3.9.1. Time period for Detecting Medical Device Deficiencies**

Medical device deficiencies that result in an incident will be detected, documented, and reported during all periods of the study in which the medical device is used.

If the investigator learns of any device deficiency at any time after a participant has been discharged from the study, and such a device deficiency is considered reasonably related to a medical device provided for the study, the investigator will notify the sponsor within 24 hours.

Medical device deficiencies and any associated AE/SAEs for associated persons (i.e, spouse, caregiver, site staff) will be collected. The associated person will be provided with safety reporting information and an authorization letter.

The method of documenting Medical Device Incidents is provided in Section [11.2](#)

#### **7.4.3.9.2. Follow-up of Medical Device Deficiencies**

Follow-up applies to all participants and associated persons, including those participants who discontinue study treatment or the study

The investigator is responsible for ensuring that follow-up includes any supplemental investigations as indicated to elucidate the nature and/or causality of the deficiency.

New or updated information will be recorded on the original completed form with all changes signed and dated by the investigator.

#### **7.4.3.9.3. Prompt Reporting of Medical Device Deficiencies to the Sponsor**

Device deficiencies will be reported to the sponsor within 24 hours after the investigator determines that the event meets the protocol definition of a device deficiency.

The medical device deficiency report form will be sent to the sponsor by email.

The sponsor will be the contact for the receipt of device deficiency reports.

#### 7.4.3.9.4. Regulatory Reporting Requirements for Device Deficiencies

The investigator will promptly report all device deficiencies occurring with any medical device used for CAB+RPV in the study, as described in Section 11.2 in order for the sponsor to fulfil the legal responsibility to notify appropriate regulatory authorities and other entities about certain safety information relating to medical devices being used in clinical studies.

The investigator, or responsible person according to local requirements (e.g., the head of the medical institution), will comply with the applicable local regulatory requirements relating to the reporting of device deficiencies to the IRB/IEC.

#### 7.4.4. Toxicity Management

Adverse events that occur during the trial should be evaluated by the Investigator and graded according to the Division of AIDS (DAIDS) toxicity scales (See Section 11.2. “Division of AIDS Table for Grading the Severity of Adult and Pediatric Adverse Events”). Additional information regarding detecting, documenting and reporting AEs and SAEs are available in Section 7.4.3 and Section 11.6.

##### 7.4.4.1. Treatment Interruption Due to an Adverse Event

IP may be interrupted at the discretion of the investigator and according to the severity of the AE. If one or more ART medication is held due to toxicity or AEs, all ART medications should be held to reduce the risk of development of resistance taking into account the length of the planned interruptions and the PK half-life of each ART of the regimen, in order to minimize the risk of development of resistance.

No toxicity-related dose reductions of IP will be allowed. IP should be restarted as soon as medically appropriate; in general, for oral dosing, this should be no longer than 14 days after discontinuation (unless Grade 3 or 4 toxicities persist). Any interruption in therapy during the Maintenance Phase, oral dosing, of greater than 7 consecutive days must be discussed with and agreed by the Medical Monitor prior to resumption of therapy. The Medical Monitor must be contacted upon becoming aware of resumption in therapy, if therapy was resumed without prior approval (Section 6.9). **IM dosing is expected to occur during the week in which the participant’s projected visit falls (as according to the first injection visit). An additional (+ or -) 7 day window, from the projected visit date, is allowable for IM dosing but not preferred.** Any interruption outside of this guidance MUST be discussed with the Medical Monitor prior to reinitiating IM IP (see Section 6.9.1).

Guidance is provided below on general participant management and IP interruptions based on the severity of the AE. Information regarding permitted substitutions \ is provided in Section 6.8. All changes in the IP regimen must be accurately recorded in the participant’s eCRF.



**Note:** For participants receiving an ABC-containing product as part of the background regimen during the Long-Term Follow-Up (LTFU) Phase, in the event of a discontinuation of ABC for any reason, re-initiation of this drug should be undertaken with caution. The investigator should obtain a complete history of the events surrounding the discontinuation of the ABC-containing product, evaluate for the possibility of a clinically suspected HSR, and initiate participant management as outlined in the Local Country Prescribing Information, regardless of a participant's *HLA-B\*5701* status. Screening for the presence of *HLA-B\*5701* is recommended prior to reinitiating treatment with ABC-containing products in participants of unknown *HLA-B\*5701* status who have previously tolerated ABC but is not required to confirm study eligibility.

#### **7.4.4.2. Grade 1 or Grade 2 Toxicity/Adverse Event**

Participants who develop a Grade 1 or Grade 2 AE or toxicity may continue study drug at the discretion of the investigator. Participants who choose to withdraw from the study due to a Grade 1 or 2 AE should have study withdrawal and follow-up evaluations completed.

**Participants who develop ALT  $\geq$ 3 times ULN while on study must consult with Medical Monitor prior to initiation or continuation of CAB LA + RPV LA**

#### **7.4.4.3. Grade 3 Toxicity/Adverse Event**

Participants who develop a Grade 3 AE or toxicity should be managed as follows:

- If the Investigator has compelling evidence that the Grade 3 AE or toxicity has not been caused by IP, dosing may continue after discussion with the Medical Monitor.
- Participants who develop a Grade 3 AE or toxicity, which the Investigator considers related or possibly related to the IP, should have the IP withheld and be rechecked each week until the AE returns to Grade 2. Once the AE is Grade  $\leq$ 2, IP may be re-started.
- Should the same Grade 3 AE recur within 28 days in the same participant, the IP should be permanently discontinued and the participant withdrawn from study.
- Participants experiencing Grade 3 AEs requiring permanent discontinuation of IP should be followed weekly until resolution of the AE and to have withdrawal study evaluations completed. A follow-up visit should be performed 2-4 weeks after the last dose of IP. Any participant receiving at least one dose of CAB LA and /or RPV LA who discontinue IP / Withdraw will initiate treatment with HAART and enter the LTFU Phase for 52 weeks of follow up.
- Participants with Grade 3 asymptomatic laboratory abnormalities should be investigated for all potential non-drug related causes, and, following discussion with the Medical Monitor, may continue IP if the Investigator has compelling evidence that the toxicity is not related to IP, with the exception of liver chemistry stopping criteria (See Section 7.4.5.1). Isolated Grade 3 lipid abnormalities do not require withdrawal of IP.

#### 7.4.4.4. Grade 4 Toxicity/Adverse Event

- Participants who develop a Grade 4 AE or toxicity must have IP permanently discontinued. However, if the Investigator has compelling evidence that the AE is not causally related to the IP, dosing may continue after discussion with, and assent from, the Medical Monitor. Participants should be rechecked each week until the AE returns to Grade 2.
- Participants experiencing Grade 4 AEs requiring permanent discontinuation of IP should be followed weekly until resolution of the AE and encouraged to complete the withdrawal and follow-up study evaluations as noted above. Any participant receiving at least one dose of CAB LA and /or RPV LA who discontinue IP / Withdraw will initiate treatment with HAART and enter the LTFU Phase for 52 weeks of follow up.
- Participants with Grade 4 asymptomatic laboratory abnormalities should be investigated for all potential non-drug related causes, and, following discussion with the Medical Monitor, may continue therapy if the Investigator has compelling evidence that the toxicity is not related to IP, with the exception of liver chemistry stopping criteria (See Section 7.4.5.1). An in-clinic follow-up visit will be performed approximately 2-4 weeks after the last dose of study medication if AEs, SAEs, or laboratory abnormalities considered potentially harmful to the participant are ongoing at the last on-study visit. Isolated Grade 4 lipid abnormalities do not require withdrawal of IP.

#### 7.4.5. Specific Toxicities/Adverse Event Management

General guidelines for the management of specific toxicities that are considered to be associated with treatment of HIV patients.

Participants who permanently discontinue study drug for reasons of toxicity should be followed weekly until resolution of the AE and encouraged to complete the withdrawal and Follow-up study evaluations as noted in Section 7.4.3.3.

##### 7.4.5.1. Liver Chemistry Stopping and Follow-up Criteria

Liver chemistry threshold stopping criteria have been designed to assure participant safety and to evaluate liver event etiology during administration of study drug and the follow-up phase. All Phase 3 participants who meet liver stopping criteria will be adjudicated by the ViiV Safety and Labelling Committee (VSLC) – resulting in a case summary, adjudication, and management plan. The VSLC contains an external expert hepatologist, familiar with both DILI and cabotegravir, who will participate in this review. This committee meets on a 3-weekly basis, and can be convened on an ad hoc basis as needed.

##### 7.4.5.2. Diarrhea

Participants with Grade 1 or 2 diarrhea may continue study treatment without interruption. Participants with diarrhea of any toxicity grade may be treated symptomatically with anti-motility agents; however, the recommended daily dose of the chosen anti-motility agent must not be exceeded. If symptoms persist or get worse on the

recommended daily dose of the chosen anti-motility agent then the anti-motility agent must be discontinued and consultation made with the Medical Monitor.

For participants with Grade  $\geq 3$  diarrhea that is unresponsive to the recommended dose of the anti-motility agents and for which an alternative etiology (e.g., infectious diarrhea) is not established, the treatment with the anti-motility agent and IP must be interrupted until resolution of diarrhea to Grade  $\leq 2$  or Baseline, after which IP and background ART may be resumed after discussion and agreement with the Medical Monitor. If Grade  $\geq 3$  diarrhea recurs within 28 days upon the resumption of IP, the IP should be permanently discontinued and the participant withdrawn from the study. Any participant receiving at least one dose of CAB LA and /or RPV LA who discontinue IP / Withdraw will initiate treatment with HAART and enter the LTFU Phase for 52 weeks of follow up.

If loperamide is used for treatment of diarrhea, local prescribing information should be followed with respect to dose and frequency of administration. Loperamide dosing should not exceed local prescribing information.

#### **7.4.5.3. Hypertriglyceridemia/ Hypercholesterolemia**

Samples for lipid measurements **must** be obtained in a fasted state according to the Time and Events table (Section 7.1). Participants who experience asymptomatic triglyceride or cholesterol elevations may continue to receive IP. Clinical management of participants with hypertriglyceridemia/hypercholesterolemia should **not** be based upon non-fasting samples (obtained in the fed state). A confirmatory fasting triglyceride and/or cholesterol level should be obtained prior to the institution of medical therapy for hyperlipidemia. Isolated Grade 3 and Grade 4 lipid abnormalities do not require withdrawal of IP.

Please see the Recommendations of the Adult AIDS Clinical Trial Group Cardiovascular Disease Focus Group [Dube, 2003] for full discussion of management of hyperlipidemia in the context of HIV therapy.

#### **7.4.5.4. Seizures**

A small number of seizure cases have been reported following CAB administration (less than 1% of all those receiving CAB in clinical studies).

. These cases have had alternative explanations for their occurrence.

ViiV Healthcare has reviewed these cases in detail and does not believe they constitute a reasonable likelihood of causation associated with CAB. This assessment is supported by the lack of preclinical signal, class effect or known CNS mechanism, the relatively low frequency of seizures relative to expected rates in both healthy and HIV positive participants and clinical confounders in each case. The Sponsor considers the risk of developing seizures on the study as being no higher than that of the rest of the HIV-1 infected population.

Seizures that occur on study should be managed according to the local guidelines on emergency seizure management which may include treatment with benzodiazepines, general supportive treatment, exclusion of metabolic and toxicological abnormalities

using laboratory tests, septic workup and excluding underlying structural abnormalities with neuroimaging.

Where seizures occur, the Sponsor would like to better characterize these occurrences to enable systematic analyses.

Investigators are requested to document and report seizure or possible seizure events promptly (within 24 hours of learning of the event) to the Sponsor for evaluation and onward reporting. Data should be documented on the appropriate eCRF seizure page.

#### **7.4.5.5. Creatine Phosphokinase (CPK) Elevation**

A Grade 3 or higher elevation in CPK should result in a repeat assessment within 2-4 weeks to ensure the result is transient or due to exercise and will not require a change in study treatment. A history regarding use of drugs known to cause increase of CPK (such as statins) physical activity or exercise preceding the CPK evaluation should be obtained.

Grade 4 elevations in CPK should have a repeat assessment after the participant has abstained from exercise for >24 hours. For persistent Grade 4 CPK elevations that are considered possibly or probably related to the IP, IP should be discontinued and the participant withdrawn from the study. Any participant receiving at least one dose of CAB LA and /or RPV LA who discontinue IP / Withdraw will initiate treatment with HAART enter the LTFU Phase for 52 weeks of follow-up.

#### **7.4.5.6. Lipase Elevations and Pancreatitis**

Participants with asymptomatic Grade 1 or 2 elevations in lipase may be followed closely for the development of symptoms.

Participants with asymptomatic Grade  $\geq 3$  elevations in lipase that are considered possibly or probably related to IP should have IP interrupted until serum lipase returns to Grade  $\leq 2$ . The lipase assay should be repeated within 2 weeks of any Grade  $\geq 3$  result. Participants with persistence of Grade  $\geq 3$  lipase in the absence of other diagnoses or reoccurrence of lipase elevation (at Grade  $\geq 2$ ) following reintroduction of IP should permanently discontinue IP.

Participants with a confirmed diagnosis of clinical pancreatitis that is considered possibly or probably related to IP should have IP held. After complete resolution of the episode, participants may be re-challenged with IP after discussion with the Medical Monitor, only if the Investigator has compelling evidence that the event was not caused by IP. Upon re-challenge, lipase determinations should be performed every 2 weeks for at least 6 weeks after re-initiation of treatment. With any elevation of lipase of Grade  $\geq 2$  or any recurrence of symptoms, the participant should discontinue IP and be withdrawn from study.

Any participant receiving at least one dose of CAB LA and /or RPV LA who discontinue IP / Withdraw will initiate treatment with HAART and enter the LTFU Phase for 52 weeks of **follow up**.

***Drug Restart Following Transient Resolving Liver Events Not Related to Study Drug***

Approval by VSLC for drug restart can be considered where:

Liver chemistries have a clear underlying cause (e.g., biliary obstruction, hypotension, and liver chemistries have improved to normal or are within  $1.5 \times$  baseline and  $ALT < 3 \times ULN$ ). Ethics Committee or IRB approval of drug restart must be obtained, as required.

If restart of drug is approved by VSLC in writing, the participant must be provided with a clear description of the possible benefits and risks of drug administration, including the possibility of recurrent, more severe liver injury or death.

The participant must also provide signed informed consent specifically for the restart. Documentation of informed consent must be recorded in the study chart.

Study drug must be administered at the dose specified by VSLC.

Participants approved by VSLC for restarting study drug must return to the clinic once a week for liver chemistry tests for a minimum of one month and thereafter for as long as clinically indicated and then laboratory monitoring may resume as per protocol. If protocol defined stopping criteria for liver chemistry elevations are met, study drug must be stopped.

Refer to Section 11.2, U.S. Department of Health and Human Services, National Institutes of Health, National Institute of Allergy and Infectious Diseases, Division of AIDS. Division of AIDS (DAIDS, 2017) Table for Grading the Severity of Adult and Pediatric Adverse Events, Version 2.1. [March 2017]. Available from: <https://rsc.tech-res.com/docs/default-source/safety/daids-ae-grading-table-mar2017.pdf>

Refer to Section 11.3, Appendix 3: Liver Safety – Required actions, Follow up Assessments and : Liver Safety – Study Treatment Restart Guidelines for further details.

**7.4.5.7. Decline in Renal Function**

Participants who experience an increase in serum creatinine from Baseline of 45 micromoles/liter ( $\mu\text{Mol/L}$ ) (or 0.5 milligrams/deciliter [ $\text{mg/dL}$ ]) should return for a confirmatory assessment within 2 to 4 weeks. A urinalysis and urine albumin/creatinine and urine total protein/albumin ratios should also be done at this confirmatory visit. If the creatinine increase is confirmed, the investigator should contact the study medical monitor to discuss additional follow-up and medical management.

Participants who have a decline in the estimated GFR (using the CKD-EPI method) of  $>50\%$  from Baseline must return for a confirmatory assessment as soon as possible [Levey, 2009]. A urinalysis and urine albumin/creatinine and urine protein/creatinine ratios should also be done at this confirmatory visit. If the estimated GFR has declined by  $>50\%$  (confirmed), then study drug should be withheld and the investigator should contact the study medical monitor to discuss the rationale for restarting study drugs (if appropriate). Consideration for confounding factors (e.g., background therapy, other

medications, dehydration, concurrent conditions) should be taken into account, and a nephrology consult may be obtained.

#### **7.4.5.7.1. Proximal Renal Tubule Dysfunctions (PRTD)**

PRTD is defined as:

Confirmed rise in serum creatinine of  $\geq 0.5$  mg/dL from Baseline AND serum phosphate  $< 2.0$  mg/dL;

Either of the above accompanied by any two of the following:

Glycosuria ( $\geq 250$  mg/dL) in a non-diabetic;

Low serum potassium ( $< 3$  mEq/L);

Low serum bicarbonate ( $< 19$  mEq/L).

Participants meeting criteria for PRTD must return for a confirmatory assessment within 2 weeks of diagnosis. A urinalysis should also be performed at the time of the confirmatory assessment. If PRTD is confirmed participants should have study drug withheld and the investigator should contact the Study medical monitor to discuss the rationale for restarting study drugs (if appropriate). Consideration for confounding factors (e.g., NRTI backbone, other medications, dehydration, concurrent conditions) should be taken into account, and a nephrology consult may be obtained. If study drug is reinitiated, it should have been withheld for no more than 4 weeks.

#### **7.4.5.8. Proteinuria**

Participants with an abnormal urine microalbumin/creatinine ratio ( $> 0.3$  mg/mg,  $> 300$  mg/g, or  $> 34$  mg/mmol) that represents a change from Baseline and no associated increase in creatinine, should have a repeat spot urine microalbumin/creatinine ratio performed within 2-4 weeks. If confirmed, then consideration should be given to additional evaluation after consultation with the study medical monitor. Additional evaluation may include a 24-hour urine protein and creatinine measurement and nephrology referral.

Participants with an abnormal urine albumin/creatinine ratio ( $> 0.3$  mg/mg,  $300$  mg/g, or  $> 34$  mg/mmol and representing a change from Baseline) and a serum creatinine increase  $> 45$   $\mu\text{mol/L}$  (or  $0.5$  mg/dL) should have confirmation of both results within 2 weeks. If confirmed, the study medical monitor should be contacted immediately. Agreement on further management should be agreed between the investigator and medical monitor.

#### **7.4.5.9. QTc Prolongation**

Participants with an average QTc interval  $> 550$  msec from three or more tracings separated by at least 5 minutes should have IP discontinued. These criteria are based on an average QTc value of triplicate ECGs. If an ECG demonstrates a prolonged QT interval, obtain 2 more ECGs over a brief period ( $\sim 5$ -10 minutes) and use the averaged QTc values of the 3 ECGs to determine whether the participant should be discontinued

from the study. If an alternative cause of the QT prolongation is determined (e.g., participant receiving drug known to cause prolonged QT or TdP), then IP may be restarted after consultation with, and agreement by, the Medical Monitor.

#### **7.4.5.10. Injection Site Reactions (ISRs)**

Injection site reactions will be managed through investigator assessment throughout the study. All ISRs that are either serious, Grade 3 or higher, or persisting beyond 2 weeks must be discussed with the Medical Monitor to determine etiology and assess appropriate continued study participation.

Digital photographs may be documented where possible on all participants who have an injection site reaction, with observable findings, that is either serious or Grade 3 or higher, or that persists beyond 2 weeks. Dermatology will be consulted on all participants who have an injection site reaction considered serious, Grade 3 or above, or if clinically significant and persistent beyond 30 days and others if the Investigator or Medical Monitor feels it is medically necessary.

Details regarding photo collection and any other follow up will be given by the Medical Monitor at the time of assessment.

ISR discomfort can be managed symptomatically (e.g., cold/warm compress, acetaminophen, ibuprofen) if the reaction is interfering with the participant's ability to perform activities of daily living. The required intervention should be documented on the appropriate eCRF page.

#### **7.4.5.11. Allergic reaction**

Participants may continue study drug for Grade 1 or 2 allergic reactions at the discretion of the Investigator. The participant should be advised to contact the Investigator immediately if there is any worsening of symptoms or if further systemic signs or symptoms develop. Antihistamines, topical corticosteroids, or antipruritic agents may be prescribed.

Participants with Grade  $\geq 3$  allergic reactions that are considered to be possibly or probably related to the study drug should permanently discontinue the CAB LA + RPV LA regimen and the participant should be withdrawn from the study. Participants should be treated as clinically appropriate and followed until resolution of the AE.

#### **7.4.5.12. Abacavir Hypersensitivity Reaction (ABC HSR)**

The most significant toxicity associated with ABC is the well-characterized drug-related hypersensitivity reaction (HSR). A detailed clinical description of this reaction (including the type and severity of events that can occur on re-challenge or reintroduction following ABC interruption for non-HSR reasons) and guidance regarding its management are included in the Local Country Prescribing Information for EPZICOM. Investigators must familiarize themselves with this information on ABC HSR in the Local Country Prescribing Information for each of these products prior to initiating participants on ABC therapy.

Studies have shown that carriage of the *HLA-B\*5701* allele is associated with a significantly increased risk of a HSR to ABC. In the prospective study CNA106030 (PREDICT-1), the use of pre-therapy screening for the presence of *HLA-B\*5701* and subsequently avoiding ABC in *HLA-B\*5701* positive patients, significantly reduced the incidence of clinically suspected ABC HSR from 7.8% (66 of 847) to 3.4% (27 of 803) ( $p < 0.0001$ ). In clinical studies EPZ108859 (ARIES) and CNA109586 (ASSERT), 0.8% (4/515) and 3.1% (6/192) of participants who were *HLA-B\*5701* negative and who received ABC developed a clinically suspected ABC HSR, respectively.

**In any participant treated with ABC, the clinical diagnosis of suspected HSR (as detailed in the Local Country Prescribing Information) must remain the basis of clinical decision making. Regardless of *HLA-B\*5701* status, it is important to permanently discontinue ABC and not re-challenge with ABC (i.e., ZIAGEN, EPZICOM/KIVEXA, TRIZIVIR, or TRIUMEQ) if a HSR cannot be ruled out on clinical grounds, due to the potential for a severe or even fatal reaction.**

#### **7.4.5.12.1. Essential Patient Information**

With reference to Local Country Prescribing Information and the ‘Participant Information and Consent Form’, Investigators must ensure that participants are fully informed regarding the following information on the hypersensitivity reaction prior to commencing ABC therapy:

- Participants must be made aware of the possibility of a hypersensitivity reaction to abacavir that may result in a life-threatening reaction or death and that the risk of a hypersensitivity reaction is increased in individuals who are *HLA-B\*5701* positive.
- Participants must also be informed that *HLA-B\*5701* negative individuals can also experience abacavir hypersensitivity reaction. Therefore, ANY participant who develops signs or symptoms consistent with a possible hypersensitivity reaction to abacavir MUST CONTACT their doctor IMMEDIATELY.
- Participants who are hypersensitive to abacavir should be reminded that they must never take any abacavir containing medicinal products (e.g., ZIAGEN, EPZICOM, KIVEXA, TRIZIVIR, or TRIUMEQ) again, regardless of their *HLA-B\*5701* status.
- In order to avoid restarting abacavir, participants who have experienced a hypersensitivity reaction should be asked to return any remaining EPZICOM / KIVEXA tablets to the Investigator or site staff.
- Participants, who have stopped abacavir for any reason, and particularly due to possible adverse reactions or illness, must be advised to contact their doctor before restarting EPZICOM / KIVEXA as more severe symptoms may recur within hours and may include life-threatening hypotension and death.
- Each participant should be reminded to read the Package Leaflet included in the EPZICOM / KIVEXA pack. They should be reminded of the importance of removing the Alert Card included in the pack, and keeping it with them at all times.



#### **7.4.5.12.2. Reporting of Hypersensitivity Reactions**

If a clinically suspected case of HSR to ABC meets one of the International Conference on Harmonization (ICH E2A, 1994 definitions of seriousness listed in Section 11.6.2 then, in addition to reporting the case as an SAE, the ABC HSR eCRF should also be completed within one week of the onset of the hypersensitivity reaction. Clinically suspected cases of HSR to ABC that do not meet criteria as an SAE can be recorded as an AE.

#### **7.4.5.13. Rash Without ABC HSR Symptoms**

**Including serious skin reactions such as Stevens-Johnson Syndrome, Toxic Epidermal Necrolysis, Erythema Multiforme or rash with significant liver dysfunction.**

Participants should be instructed to contact the Investigator as soon as possible if they develop a rash on study.

Participants who develop rash of any grade should be evaluated for the possibility of an ABC HSR or a serious skin reaction such as Stevens - Johnson syndrome (SJS), Toxic Epidermal Necrolysis (TEN) or Erythema Multiforme. SJS, TEN, and Erythema Multiforme have been reported very rarely in patients taking ABC-containing products. These patients generally do not have the cluster of additional symptoms (e.g., gastrointestinal and respiratory) that characterize the ABC HSR, but they do have features typical of these serious skin reactions.

If a serious skin reaction develops, ABC (and / or all other concurrent medication(s) suspected in the Investigators causality assessment) should be discontinued, and the participant should not be re-challenged with any ABC-containing medicinal product (i.e., ZIAGEN, TRIZIVIR, EPZICOM, or KIVEXA).

As many products other than abacavir also cause rash and/or serious skin reactions, all other medicinal products that the participant is receiving should also be reviewed and discontinued as appropriate.

The following guidance is provided for clinical management of participants who experience rash alone in the absence of accompanying diagnosis of ABC HSR, systemic or allergic symptoms or signs of mucosal or target lesions.

CAB is an analogue of DTG and mild to moderate rash is an expected adverse reaction for DTG-containing ART. Episodes generally occur within the first ten weeks of treatment, rarely require interruptions or discontinuations of therapy and tend to resolve within two to three weeks. No instances of serious skin reaction, including Stevens-Johnson syndrome (SJS), toxic epidermal necrolysis (TEN) and erythema multiforme, have been reported for DTG in clinical trials. For further characterization of HSR and rash observed with DTG-containing ART, please see the current version of the CAB IB .

Rash is an adverse drug reaction (ADR) for RPV. In clinical trials, most rashes emerged during the first 4 weeks of treatment, were transient, and usually mild (Grade 1) to

moderate (Grade 2). There were no Grade 4 rashes and none were serious. Treatment-related Grade 3 rash was reported in 0.1% of participants in the RPV group. Treatment-related rash led to permanent discontinuation in 0.1% of participants in the RPV group. No cases of erythema multiforme, SJS or TEN have been reported during clinical development of RPV.

Participants with an isolated Grade 1 rash may continue study drug at the Investigator's discretion. The participant should be advised to contact the Investigator immediately if there is any worsening of the rash, if any systemic signs or symptoms appear, or if mucosal involvement develops.

Participants may continue study drug for an isolated Grade 2 rash. However, study drug (and all other concurrent medication(s) suspected in the Investigators causality assessment) should be permanently discontinued for any Grade  $\geq 2$  rash that is associated with an increase in ALT. The participant should be advised to contact the physician immediately if rash fails to resolve (after more than two weeks), if there is any worsening of the rash, if any systemic signs or allergic symptoms develop, or if mucosal involvement develops.

Participants should permanently discontinue study drug [and all other concurrent medication(s) suspected in the Investigators causality assessment] for an isolated Grade 3 or 4 rash, except where the etiology of the rash has been definitively diagnosed as NOT attributable to study drug (see below), and the participant should be withdrawn from the study. Participants should be treated as clinically appropriate and followed until resolution of the AE. Every effort should be made to collect as much information as possible about the evolution of the event and any relationship with potentially related medical events (e.g., viral infection) or start of concomitant medication.

The rash and any associated symptoms should be reported as adverse events and appropriate toxicity ratings should be used to grade the events (based on DAIDS toxicity gradings – see Section 11.2, Appendix 2).

However, if the etiology of the rash has been definitively diagnosed as being unrelated to study drug and due to a specific medical event or a concomitant infection or a concomitant non-study medication, routine management should be performed and documentation of the diagnosis provided. In this situation, the study drug should be continued.

Participants in the Follow-Up Phase who are receiving ABC as part of their regimen should be evaluated for the possibility of a clinically suspected ABC HSR and managed appropriately as outlined in the local prescribing information for ABC.

**Any rash that is possibly related to study drug, and is present between Day 1 and The Week 4b visit for participants in the Oral Lead-in Phase, must be discussed with the Medical Monitor prior to initiation of CAB LA or RPV LA.**

Any participant receiving at least one dose of CAB LA and /or RPV LA who discontinue IP / Withdraw will initiate treatment with HAART and enter the LTFU Phase for 52 weeks of follow-up.

#### **7.4.6. Suicidal Risk Monitoring**

Participants with HIV infection may occasionally present with symptoms of depression and/or suicidal ideation or behavior. In addition, there have been some reports of depression, suicidal ideation and behavior (particularly in participants with a pre-existing history of depression or psychiatric illness) in some patients being treated with INIs. Additionally, depression and anxiety has been reported in some participants being treated with RPV. Therefore, it is appropriate to monitor and closely observe participants prospectively before and during treatment for suicidal ideation and/or behavior, or any other unusual changes in behavior. It is recommended that the Investigator consider mental health consultation or referral for participants who experience signs of suicidal ideation or behavior.

Participants presenting with new onset/treatment emergent depression should be advised to contact the investigator immediately if symptoms of severe acute depression (including suicidal ideation/attempts) develop, because medical intervention and discontinuation of the study medication may be required.

Assessment of treatment-emergent suicidality will be monitored during this study using the electronic version of the Columbia Suicide-Severity Rating Scale (eC-SSRS). The definitions of behavioural suicidal events used in this scale are based on those used in the Columbia Suicide History Form [Posner, 2007]. Questions are asked on suicidal behavior, suicidal ideation, and intensity of ideation. Screening visit questions will be in relation to lifetime experiences and current experiences (within the past 2 months) and all subsequent questioning in relation to the last assessment. The eC-SSRS is to be administered as a patient completed questionnaire specified in the Time and Events Table (Section 7.1). The eC-SSRS will be conducted electronically by telephone or by computer/tablet connected to the internet.

Additionally, the investigator will collect information using the Possible Suicidality-Related AE (PSRAE) eCRF form in addition to the Adverse Event (non-serious or Serious Adverse Events) eCRF form on any participant that experiences a possible suicidality-related adverse event while participating in this study. This may include, but is not limited to, an event that involves suicidal ideation, a preparatory act toward imminent suicidal behavior, a suicide attempt, or a completed suicide. The investigator will exercise his or her medical and scientific judgment in deciding whether an event is possibly suicide-related. PSRAE forms should be completed and reported to ViiV/GSK within one week of the investigator diagnosing a possible suicidality-related adverse event. All sites should have a plan in place for managing possible risks for suicide related events.

#### **7.4.7. Pregnancy**

##### **7.4.7.1. Pregnancy testing**

Women of childbearing potential must have a negative pregnancy test at Screening, and at Baseline (Day 1). Pregnancy testing will also be conducted as per the Time and Events Table (Section 7.1) and at anytime during the trial when pregnancy is suspected.

If pregnancy is confirmed, a discussion with the pregnant study participant assessing the benefit/risk assessment of continuing in the study will be undertaken. If, after this discussion, the participant would like to continue in the study, this will be allowed, provided the pregnant participant signs the pregnancy specific ICF addendum. See [Appendix 11](#) for details.

Pregnant participants who remain in the study do not need pregnancy testing during the study, for the duration of their pregnancy.

Additionally, the Medical Monitor may request that a urine pregnancy test be performed in the event of a treatment interruption greater than 7 days.

#### **7.4.7.2. Rationale for Continued Use in Pregnancy**

Additional data regarding the use of CAB + RPV LA during pregnancy, and management of pregnant participants remaining in the study are found in [Appendix 11](#)

The use of CAB + RPV LA during pregnancy may offer unique benefits. It is well documented that treatment adherence challenges to oral therapy exists both in the peri-partum and post-partum periods with LA dosing offering a unique opportunity to overcome such adherence challenges. LA therapy may also help with nausea (50 % mild to moderate) or hyperemesis (2%) that is frequently seen, especially during the first trimester of gestation.

Participants on LA dosing who become pregnant will have exposures throughout pregnancy due to the long half-life and PK tail of CAB/RPV. Prior to this protocol amendment, pregnant participants would have been withdrawn from the study, and initiated on an alternative oral ART regimen. Alternative regimens consist of either 2 or 3 antiretrovirals to protect the life of the mother and for the prevention of MTCT. This regimen, combined with the long half-life and PK tail of CAB/RPV, would potentially expose the fetus to additional ARVs during gestation (in some cases upwards of 5 antiretrovirals).

Given the risk/benefit ratio for cabotegravir and rilpivirine LA dosing in WOCBP, coupled with concerns of increasing fetal exposure to several additional antiretrovirals upon participant withdrawal, this amendment to the protocol will allow pregnant participants to remain in the study after a pregnancy specific ICF addendum is signed by the participant.

#### **7.4.7.3. Time Period for Collecting Pregnancy Information**

Pregnancy information will be collected from Day 1 until the last follow-up assessment. This includes the entirety of the LTFU Phase.

Pregnant study participants who consent to remain in the study during pregnancy will continue to have all clinical assessments (with the exception of pregnancy test) performed as per the Time and Events Table (Section 7.1), including the collection of additional PK samples for CAB and RPV. See [Appendix 11](#) for details.

Pregnant participants who have received at least one dose of CAB LA or RPV LA and decide NOT to continue in the study during pregnancy will enter the LTFU Phase of the study and will be monitored for 52 weeks after the last LA dose. Moreover, an alternative oral HAART will be initiated, at the discretion of the PI and in discussion with the Medical Monitor and If a participant becomes pregnant within 52 weeks of the last dose of study drug the participant should notify the study site.

For women who become pregnant while on LA therapy and who consent to continue with LA dosing, a descriptive analysis for these women will be obtained and will include but not be limited to VLs, CD4 cell count, CAB and RPV plasma concentrations and unbound [CAB] concentrations during pregnancy in addition to the first post-partum visit after delivery.

#### **7.4.7.4. Action to be Taken if Pregnancy Occurs**

Any pregnancy that occurs during study participation must be reported using a clinical trial pregnancy form. To ensure participant safety, if a pregnancy is reported then the investigator should inform GSK within 24 hours of learning of the pregnancy and should follow the procedures outlined in [Appendix 7](#).

Pregnant participants who elect to continue in the study and receive CAB + RPV LA must sign a pregnancy specific ICF addendum. Cabotegravir and rilpivirine are detected in systemic circulation for up to 12 months or longer after discontinuing injections of CAB + RPV LA; therefore, consideration should be given to the potential for fetal exposure during pregnancy and should be discussed between the study participant and the study PI. Participants who become pregnant during the study and elect to continue in the study and receive CAB+RPV LA, will have additional samples collected (including PK samples to monitor cabotegravir and rilpivirine exposure levels throughout the pregnancy, see [Appendix 11](#)) and at the time of delivery.

The pregnancy must be followed up to determine outcome (including premature termination) and status of mother and child(ren). Pregnancy complications and elective terminations for medical reasons must be reported as an AE or SAE. Spontaneous abortions must be reported as SAEs.

Any SAE occurring in association with a pregnancy brought to the investigator's attention after the participant has completed the study and considered by the investigator as possibly related to the study treatment, must be promptly reported to ViiV/GSK.

GSK's central safety department will also forward this information to the Antiretroviral Pregnancy Registry. The international registry is jointly sponsored by manufacturers or licensees of ARV products. Additional information and a list of participating manufacturers/licensees are available from <http://apregistry.com/index.htm>.

#### **7.4.8. Physical Exams**

Physical exams should be conducted as part of normal routine clinical care. Abnormalities noted during any exam must be recorded in the eCRF (e.g., in the current medical conditions or AE logs).

- A complete physical examination will include, at a minimum, assessment of the Cardiovascular, Respiratory, Gastrointestinal, and Neurological systems. Height and weight will also be measured and recorded as per the Time and Events Table in Section 7.1 above.
- A brief physical examination will include, at a minimum assessments of the skin, lungs, cardiovascular system, and abdomen (liver and spleen).
- The site of IM injection administration should be assessed at every visit for signs of any possible reaction. See Section 7.4.5.10 for additional information.
- Investigators should pay special attention to clinical signs related to previous serious illnesses.

#### **7.4.9. Vital Signs**

Vital signs will be measured in semi-supine position after 5 minutes rest and will include temperature, systolic and diastolic blood pressure and pulse rate. These will be recorded as per the Time and Events Table in Section 7.1.

#### **7.4.10. Electrocardiogram (ECG)**

A 12-lead ECG will be performed in a semi-supine position. On Day 1, (Baseline), ECGs should be performed in triplicate prior to first dose. At Day 1 and Week 48 of the Maintenance Phase, a 2 hour post dose ECG will be performed for participants receiving CAB LA + RPV LA with an allowable window of  $\pm 30$  minutes. An ECG machine that automatically calculates the heart rate and measures PR, QRS, QT, and QTc intervals is preferred, and these calculated numbers can be used for reporting purposes. Otherwise, an appropriately qualified ECG reader must interpret the results. The same interpreter should assess all ECGs for each participant. Regardless, each ECG should be reviewed by a qualified ECG reader. The qualified ECG reader will make the non-calculated ECG interpretations. Refer to the Time and Events Table for collection timepoints (Section 7.1). Refer to Section 5.5.2 for [QTc] withdrawal criteria and additional [QTc] readings that may be necessary

#### **7.5. Pharmacokinetics**

Plasma samples for determination of CAB and RPV concentrations will be collected throughout the Maintenance and Extension Phases of the study. Additional samples will be collected for storage during the LTFU Phase (blood and plasma). Samples (blood and plasma) for determination of RPV concentrations will be protected from light at all times, from sampling collection through analysis.

Pregnant participants will have additional PK samples collected during the duration of the pregnancy. See [Appendix 11](#) for details.

#### **7.5.1. PK Sample Collection**

Blood samples for evaluation of CAB (2mL each) and RPV (2 mL each) plasma PK concentrations will be collected from all participants as described in [Table 10](#).

For participants transitioning from oral SOC, at Week 4b PK samples should be collected within the window of 20-28 hours after the last oral dose of CAB + RPV was taken the day prior to the clinic visit. Participants will take their final dose of oral CAB + RPV in the clinic at Week 4b after the pre-dose PK sample.

These participants will be expected to complete a PK dosing diary card noting the date and time of the last three oral doses of IP prior to the scheduled clinic visits at Week 4b. The information from the diary card and the actual date and time of the PK samples will be recorded in the eCRF. Additionally, dosing information on the clinic day, including dosing and the actual date and time of the PK samples, must be recorded on the eCRF.

Plasma concentrations will be summarized and used to evaluate potential exposure-response relationships.

The timing of PK samples may be altered and/or PK samples may be obtained at additional time points to ensure thorough PK monitoring.

**Table 10 CAB and RPV Plasma Pharmacokinetic Sample Schedule**

Group	Analytes	Sample Times Relative to Dose
Participants receiving CAB LA + RPV LA <b>Q4W</b> injections	CAB and RPV	<p><u>Pre-Dose:</u> Weeks 4b, 8, 16, 24, 32, 40, 48, 96, and 152</p> <p><u>A PK sample will be taken at Withdrawal.</u></p> <p><u>PK samples for storage only:</u></p> <p>Pre-dose: Week 12, 20, 28, 36, 44, 52, 56, 60, 64, 68, 72, 76, 80, 84, 88, 92, 100</p> <p><u>Long-term follow-up Period (off-drug; storage sample)</u></p> <p>Months 3, 6, 9, and 12</p>
Participants receiving CAB LA + RPV LA <b>Q8W</b> injections	CAB and RPV	<p><u>Pre-Dose:</u> Day 1*, Weeks 4b**, 8, 16, 24, 32, 40, 48, 96, and 152</p> <p><u>1 Week Post Dose:</u> Week 9 and Week 41</p> <p><u>A PK sample will be taken at Withdrawal</u></p> <p><u>PK samples for storage only:</u></p> <p>Pre-dose: Weeks 56, 64, 72, 80, 88, 100</p> <p><u>LTFU Period (off-drug; storage sample)</u></p> <p>Months 3, 6, 9, and 12</p> <p>* Day 1 sample required only for those transitioning from ATLAS on Q4W injections.</p> <p>**Week 4b sample required only for participants transitioning from oral SOC and requiring oral CAB + RPV Lead-in</p>

**PK window collection:** All scheduled PK samples should be collected on the Day of the corresponding visit. Pre-dose samples will be taken prior to performing dosing within the clinic. Pre-dose sample collection at Week 4b (for participants transitioning from the current ART arm) should be collected 20 to 28 hours after the last oral dose of CAB and RPV was taken.

If a participant withdraws from the study a PK sample should be collected as early as practically possible (i.e., at withdrawal visit or on the day the withdrawal decision was made).

Additional details concerning handling of PK samples, labeling and shipping directions will be supplied in the central laboratory manual.



Samples for determination of RPV will be protected from light until analysed.

### **7.5.2. Rationale of PK Sampling Strategy**

Blood sampling for CAB and RPV concentrations will be performed during the Maintenance Phase of the study to evaluate PK in HIV infected participants. The proposed PK visits and sampling scheme at each visit presented in Section 7.1 is based on consideration of available PK data to support interim and final PK and PK/Pharmacodynamic (PD) analysis planned in this study.

### **7.5.3. Sample Analysis**

#### **7.5.3.1. CAB Sample Analysis**

Plasma CAB analysis will be performed under the control of PTS-DMPK, GlaxoSmithKline, the details of which will be included in the Study Reference Manual (SRM). Concentrations of CAB will be determined in plasma samples using the currently approved bioanalytical methodology. Raw data will be archived at the bioanalytical site (detailed in the SRM).

Once the plasma has been analyzed for CAB any remaining plasma may be analyzed for other compound-related metabolites and the results reported under a separate GSK PTS-DMPK, GSK protocol. No human DNA analysis will be performed on these samples.

#### **7.5.3.2. RPV Sample Analysis**

Plasma RPV analysis will be performed under the control of Janssen R&D. Concentrations of RPV will be determined in plasma samples using the currently approved bioanalytical methodology. Raw data will be archived at the bioanalytical site.

Once the plasma has been analyzed for RPV any remaining plasma may be used by the sponsor for further exploratory work on pharmacokinetics, metabolites, plasma protein binding, protein analysis, and biochemistry. No human DNA analysis will be performed on these samples.

## **7.6. Genetics**

Information regarding genetic research is included in [Appendix 5: Genetic Research](#).

## **7.7. Viral Genotyping and Phenotyping**

Whole venous blood samples will be obtained from each participant to provide PBMCs and plasma for storage samples according to the Time and Events Table (see Section 7.1) for potential viral genotypic and phenotypic analyses.

Details concerning the handling, labeling and shipping of these samples will be supplied separately. Genotypic and phenotypic analyses may be carried out by Monogram Biosciences using, but not limited to, their Standard PhenoSense and GenoSure testing methods for protease (PRO), reverse transcriptase (RT), and integrase assays.

### 7.7.1. HIV-1 Polymerase Viral Genotyping and Phenotyping

Participants meeting confirmed virologic failure will have plasma samples tested for HIV-1 PRO and RT genotype and phenotype and HIV-1 integrase genotype and phenotype from samples collected at the time of meeting suspected virologic failure; these results will be reported to the investigator as soon as available to provide guidance for election of an alternative regimen.

### 7.7.2. HIV-1 Exploratory Analysis

Additional analyses for HIV-1 resistance may, for example, be carried out on peripheral blood mononuclear cell (PBMC) samples collected at Baseline and/or on stored blood samples from other relevant time points. These analyses may include but are not limited to additional viral genotyping and/or phenotyping, as well as other virologic evaluations such as linkage and minority species analyses, low level HIV-1 RNA quantitation and measurement of viral replicative capacity. HIV-1 PRO and RT genotype and phenotype and HIV-1 integrase genotype and phenotype will also be determined on the last on-treatment isolates from participants who have HIV-1 RNA  $\geq 200$  c/mL regardless of confirmatory HIV-1 RNA.

## 7.8. Value Evidence and Outcomes

Health outcomes assessments will be conducted according to the Time and Events Table (Section 7.1). Assessments are recommended to be administered with a paper instrument at the beginning of the visit prior to collection of blood for analysis and other scheduled assessments.

The “Preference” questionnaire will assess whether patients prefer the CAB LA + RPV LA injectable treatment or the daily oral ARV regimen, and assess preference for the CAB LA + RPV LA Q8W regimen or CAB LA + RPV LA Q4W regimen. The “Preference” questionnaire will include 3 questions evaluating preference of HIV treatment and the attributes supporting this preference.

The HIV Treatment Satisfaction Questionnaire (HIVTSQ) [Woodcock, 2001 and Woodcock, 2006] was developed to evaluate treatments for HIV and patient satisfaction. The original HIVTSQ included 10 items and underwent two stages of psychometric validation (Woodcock, 2001, Woodcock, 2006). Recently, the HIVTSQ was adapted to include injectable treatment for HIV following a qualitative study with HIV patients in five European countries. The adaptation of the HIVTSQ included two additional items related to the mode of administration (i.e., long acting intramuscular injection). These are:

CCI - This section contained Clinical Outcome Assessment data collection questionnaires or indices, which are protected by third party copyright laws and therefore have been excluded.

Psychometric analyses from three datasets (one from the UK, one from the USA and one from the LATTE-2 trial) reveal that the addition of two items in the original version of the HIVTSQ is suitable and does not reduce the overall validity of the questionnaire. The current study will be using the HIVTSQs (status version) and the revised HIVTSQc (change version) of this recently developed HIVTSQ 12-item questionnaire. The HIVTSQ 12-item questionnaire retains the option of calculating the total score as if it only had the original 10 items (as the original 10 items are included in the HIV-TSQ12). In addition, it allows for calculation of an 11-item scale score including the “CCI [REDACTED]” item (item-11). The “CCI [REDACTED]” item (item-12) will be included in the questionnaire as a stand-alone item to evaluate potentially painful injectables. These measures will assess change in treatment satisfaction over time (in the same participants) and compare current satisfaction with previous treatment satisfaction, from an earlier time point.

The Perception of Injection (PIN) questionnaire explores the bother of pain at the injection site and ISR, anxiety before and after injection, willingness to receive an HIV injectable treatment the following visit and satisfaction with the mode of treatment administration of individuals receiving injection and perceptions of individuals associated with receiving injections. The PIN questionnaire was derived from the Vaccines' Perception of Injection (VAPI) questionnaire (Chevat, 2009), and adapted for HIV-infected patients who will receive the CAB LA and RPV LA regimen. This measure contains 21 items that measure pain at injection site, local site reactions, impact on functioning and willingness to pursue injectable treatment outside of a clinical trial. Scores range from 1 to 5, and questions are phrased in such a way as to ensure that 1 always equated with the most favourable perception of vaccination, and 5 the most unfavourable.

The ACCEPT questionnaire is a generic medication acceptance measure assessing how patients weigh advantages and disadvantages of long-term medications (Marant, 2012). ACCEPT may be a predictor of patients' future adherence to and/or persistence with their treatment. While the ACCEPT questionnaire consists of 25 items that capture six dimensions, we will use three questions that focus on general acceptance of study medication.

The HIV/AIDS Targeted Quality of Life (HAT-QoL) instrument [Holmes, 1998] originally contained 42 items, grouped into nine dimensions, assessing overall function and well-being. For the purposes of this study, ViiV Healthcare is using a shorter version adapted from the original version. This shorter version contains 14 items grouped into the three following dimensions: “life satisfaction”, “disclosure worries” and “HIV medication”. All items use a “past 4 weeks” timeframe and a Likert response scale from 1=“all of the time” to 5=“none of the time”

The “Reason for Switch” question will contain a single item exploring the reasons why patients choose to switch study medication. The single item will include six possible response options.

Qualitative interviews with participants and/or health care providers at study sites may be conducted regarding their experience with study treatment. These would be conducted

under a separate IRB approved consent. Participation in the interviews would be voluntary.

### **7.8.1. Value Evidence and Outcomes Endpoints (Secondary)**

- The “Preference” questionnaire will assess preference for CAB LA + RPV LA every 8 weeks or CAB LA + RPV LA every 4 weeks compared to oral ARV regimen, and preference for CAB LA + RPV LA every 4 weeks compared to CAB LA + RPV LA every 8 weeks at Week 48 (or Withdrawal).
- Change from Week 8 in Dimension scores (e.g., “Bother of ISRs”, “Leg movement”, “Sleep”, and “Injection Acceptance”) and individual item scores assessing pain during injection, anxiety before and after injection, willingness to be injected in the future and overall satisfaction with mode of administration over time using the Perception of iNjection questionnaire (PIN) at Weeks 24, 48, and Week 152 (or Withdrawal).
- Proportion of participants considering pain and local reactions following injection to be extremely or very acceptable based on the acceptability score over time using the Perception of iNjection questionnaire (PIN).
- Change from Baseline (Day 1) in total “treatment satisfaction” score, and individual item scores of the HIVTSQs at Weeks 24, 48 and 152 (or Withdrawal).
- Change in treatment satisfaction over time (using the HIVTSQc) at Week 48 (or Withdrawal).
- Change from Baseline (Day1) in treatment acceptance (at Weeks 24, 48 and 152(or Withdrawal from the study) using the “General acceptance” dimension of the Chronic Treatment Acceptance (ACCEPT) questionnaire.
- Change from Baseline (Day1) in HR QoL (using the HAT-QoL short form) at Weeks 24, and 48, (or Withdrawal).

### **7.8.2. Value Evidence and Outcomes Endpoints (Exploratory)**

- The “Reason for Switch” question will be administered at Day 1 (Baseline) for patients randomized from oral SOC, to assess the reasons for willingness to switch ART.
- The “Reason for Switch” question will be administered at Day 1(Baseline) for patients randomized from CAB LA + RPV LA every 4 weeks in ATLAS, to assess the reasons for willingness to continue long-acting ART.
- A preference questionnaire will be administered to participants receiving oral bridging during the Maintenance and/or Extension Phases in order to explore preference for CAB + RPV LA Q4W or Q8W compared to daily oral HIV medication at W152 or upon WD visit if occurred at or before Week 152.

**7.8.3. Guidance for administering the different versions of HIVTSQc, Preference and Reason for Switch Questionnaires in ATLAS-2M**

*For the questionnaires not included below, HIVTSQs, HAT-QoL, ACCEPT and PIN, there only exists one version of each PRO that will be administered to all patients.*

Questionnaire	Version	Week visit in ATLAS-2M	Treatment Arm in ATLAS-2M	Treatment before entering ATLAS-2M	Patients in Extension phase in ATLAS
HIVTSQc	Q4W ATLAS to Q4W ATLAS-2M	Week 48 / Withdrawal	Currently on Q4W	Randomized at Day 1 in Q4W arm in ATLAS	Even if patients remained in extension phase in ATLAS consider only the initial arm they were randomized in Day 1 in ATLAS
	Q4W ATLAS to Q8W ATLAS-2M	Week 48 / Withdrawal	Currently on Q8W	Randomized at Day 1 in Q4W arm in ATLAS	
	SOC to Q4W or Q8W ATLAS-2M	Week 48 / Withdrawal	Currently on Q4W or Q8W	Any SOC treatment:  Randomized at Day 1 in SOC in ATLAS or coming outside of ATLAS	
Preference	Injection to Injection treatment	Week 48 / Withdrawal	Currently on Q8W	Randomized at Day1 in Q4W arm in ATLAS	Even if patients remained in extension phase in ATLAS consider only the initial arm they were randomized in Day 1 in ATLAS
	Oral to Injection treatment	Week 48 / Withdrawal	Currently on Q4W or Q8W	Any SOC treatment:  Randomized at Day 1 in SOC in ATLAS or coming outside of ATLAS  Continuing	

Questionnaire	Version	Week visit in ATLAS-2M	Treatment Arm in ATLAS-2M	Treatment before entering ATLAS-2M	Patients in Extension phase in ATLAS
				Q4W from ATLAS	
	Reason for Oral Bridging and Preference questionnaire	Week 152 / Withdrawal	Currently on Q4W or Q8W	SOC and Q4W from ATLAS	Not applicable.
Reason for Switch		Day 1	Currently on Q4W or Q8W	Any SOC treatment:  Randomized at Day 1 in SOC in ATLAS or coming outside of ATLAS	Administer again even if patients were administered the “reason for switch” at week 52 in ATLAS.
Reason for Continuation		Day 1	Currently on Q4W or Q8W	Randomized at Day 1 in Q4W arm in ATLAS	

## 8. DATA MANAGEMENT

- For this study participant data will be entered into GSK defined eCRFs, transmitted electronically to GSK or designee and combined with data provided from other sources in a validated data system.
- Management of clinical data will be performed in accordance with applicable GSK standards and data cleaning procedures to ensure the integrity of the data, e.g., removing errors and inconsistencies in the data.
- Adverse events and concomitant medications terms will be coded using Medical Dictionary for Regulatory Activities (MedDRA) and an internal validated medication dictionary, GSKDrug.
- eCRFs (including queries and audit trails) will be retained by GSK, and copies will be sent to the investigator to maintain as the investigator copy. Participant initials will not be collected or transmitted to GSK according to GSK policy.

Please refer to [Appendix 10](#) in Section 11.10 for study management information during the COVID-19 pandemic.

## 9. STATISTICAL CONSIDERATIONS AND DATA ANALYSES

The study is designed to demonstrate that the antiviral effect of Q8W dosing with CAB LA + RPV LA is non-inferior to Q4W dosing CAB LA + RPV LA in subjects stably suppressed on an oral SOC regimen or Q4W CAB LA + RPV LA regimen prior to randomization. Non-inferiority in the proportion of participants with HIV-RNA  $\geq 50$  c/mL at Week 48 (defined by the US FDA snapshot algorithm) can be concluded if the upper bound of a two-sided 95% confidence interval for the difference between the two treatment arms (Q8W – Q4W) is less than 4%.

If  $f_{Q8W}$  is the snapshot failure rate for Q8W CAB LA + RPV LA, and  $f_{Q4W}$  is the snapshot failure rate for Q4W CAB LA + RPV LA then the hypotheses can be written as follows:

$$H_0: f_{Q8W} - f_{Q4W} \geq 4\% \quad \text{vs} \quad H_1: f_{Q8W} - f_{Q4W} < 4\%$$

### 9.1. Sample Size Considerations

This study will randomize approximately 510 participants per arm. Assuming the true proportion with HIV-1 RNA  $\geq 50$  c/mL is 3% for the Q8W arm and 2% for the Q4W arm, a non-inferiority margin of 4%, and a 2.5% one-sided significance level, this sample size would provide at least 85% power to show non-inferiority at Week 48 (using unpooled Z test statistic). With this sample size, 90% power would be achieved assuming a 1% treatment difference and true proportions with HIV-1 RNA  $\geq 50$  c/mL of 2.63% for the Q8W arm and 1.63% for the Q4W arm.

With 510 subjects per arm and assuming an observed proportion HIV-RNA  $\geq 50$  c/mL is 2% for Q4W, the largest observed treatment difference to achieve non-inferiority with respect to a 4% margin is 1.92 percentage points. This equates approximately to observing an excess of 10 subjects on the Q8W arm (10 subjects on Q4W vs. 20 subjects on Q8W).

This sample size of 510 participants per arm will also provide at least 90% power (using unpooled Z test statistic) to show non-inferiority in the proportion of participants with plasma HIV-1 RNA  $< 50$  c/mL (per FDA's snapshot algorithm) at Week 48 over a range of true response rates, on the basis of a -10% non-inferiority margin and 2.5% one-sided significance level (see [Figure 15](#)). For example, assuming true response rate for the Q8W arm and Q4W arm are both 92%, the power is  $\geq 99\%$  to show non-inferiority for this key secondary endpoint.

#### 9.1.1. Rationale for non-inferiority margin

A non-inferiority margin of 4% has been chosen for this study because a snapshot proportion with HIV-1 RNA  $\geq 50$  c/mL at Week 48 in this range is considered clinically tolerable given the Q8W regimen will offer important advantages over the Q4W regimen

such as reduced injection frequency, and may offer better adherence and treatment satisfaction. This margin is also in concordance with the current FDA Guidance for Industry (FDA, 2015), which is the most current regulatory guidance from either the European Medicines Agency (EMA) or FDA and includes specific recommendations regarding switch studies.

### 9.1.2. Assumption for Snapshot Proportion with HIV-RNA $\geq 50$ c/mL at Week 48 (Primary Endpoint)

For the sample size calculation, assumptions regarding the true proportion with HIV RNA  $\geq 50$  c/mL for each arm were informed by data from the LATTE-2 Phase 2b study (Table 11). These data suggest a rate of 2% for Q4W and a possibly higher rate in the neighbourhood of 3% for Q8W.

Two important changes to the current study in relation to the LATTE-2 study were also considered in setting the sample size. Firstly, the loading dose schedule for Q8W has been modified in an attempt to optimize the pharmacokinetics of CAB LA + RPV LA. Secondly, a re-testing strategy (see Section 5.5.5.1) has been added to reduce the number of subjects counted as having HIV RNA  $\geq 50$  c/mL in the primary analysis at key timepoints because of transient blips (consistent with the FDA's guidance for the Snapshot endpoint). Through these changes, it is possible that the proportions with HIV RNA  $\geq 50$  copies/mL will be lower than that observed in the LATTE-2 study.

**Table 11 Snapshot Analysis Outcomes for LATTE-2 Phase IIb Study of CAB LA + RPV LA (Intent-to-Treat Maintenance Exposed Population)**

Week 48			
Study	Maintenance Treatment Arm	HIV-RNA <50	HIV-RNA $\geq 50$
LATTE-2 (ITT-ME) <sup>a</sup>	CAB LA + RPV LA Q8W (N=115)	92%	8/115 (7%)
	CAB LA + RPV LA Q4W (N=115)	91%	1/115 (<1%)
	Pooled LA (N=230)	92%	6/230 (4%)
	Oral CAB + 2NRTIs (N=56)	89%	1/56 (2%)
Week 96			
LATTE-2 (ITT-ME) <sup>b</sup>	CAB LA + RPV LA Q8W (N=115)	94%	5/115 (4%)
	CAB LA + RPV LA Q4W (N=115)	87%	0/115 (0%)
	Pooled LA (N=230)	90%	5/230 (2%)
	Oral CAB + 2NRTIs (N=56)	84%	5/56 (2%)

a) Participants had HIV-1 RNA <50 c/mL at Week -4 and received oral CAB 30 mg + 2 NRTIs as initial induction period therapy from Week -20 to Day 1.

b) Participants had HIV-1 RNA <50 c/mL at Week 20 and switched from oral CAB 30 mg + 2 NRTIs to Oral CAB 30 mg + RPV at Week 24.

### 9.1.3. Assumption for Response Rate at Week 48 (Secondary Endpoint)

Given the response rates shown in Table 11, a reasonable assumption for the true response rate (HIV-1 RNA <50 c/mL) for both arms is 92%.

### 9.1.4. Sample Size Sensitivity

Figure 15a (left panel) shows the sensitivity of the power curve for the primary comparison to different assumed 'true' proportions with HIV-RNA  $\geq 50$  c/mL with 510



randomized participants per arm based on calculations using an unpooled Z test statistic and asymptotic approximation. For example, if the true rate for Q8W is 1.5 percentage points higher than Q4W (green line), then the study would still have over 80% power to meet its primary objective if the Q4W rate is less than 1.3%.

Figure 15b (right panel) shows the impact on power to changes in the sample size assuming a 2% true-rate for Q4W. Power remains at least 80% for sample sizes as low as 425 per arm if the true Q8W rate is at most 1-percentage point inferior to Q4W.

**Figure 15 Sensitivity of Estimated Power for Snapshot Proportion with HIV-RNA  $\geq$  50 c/mL**

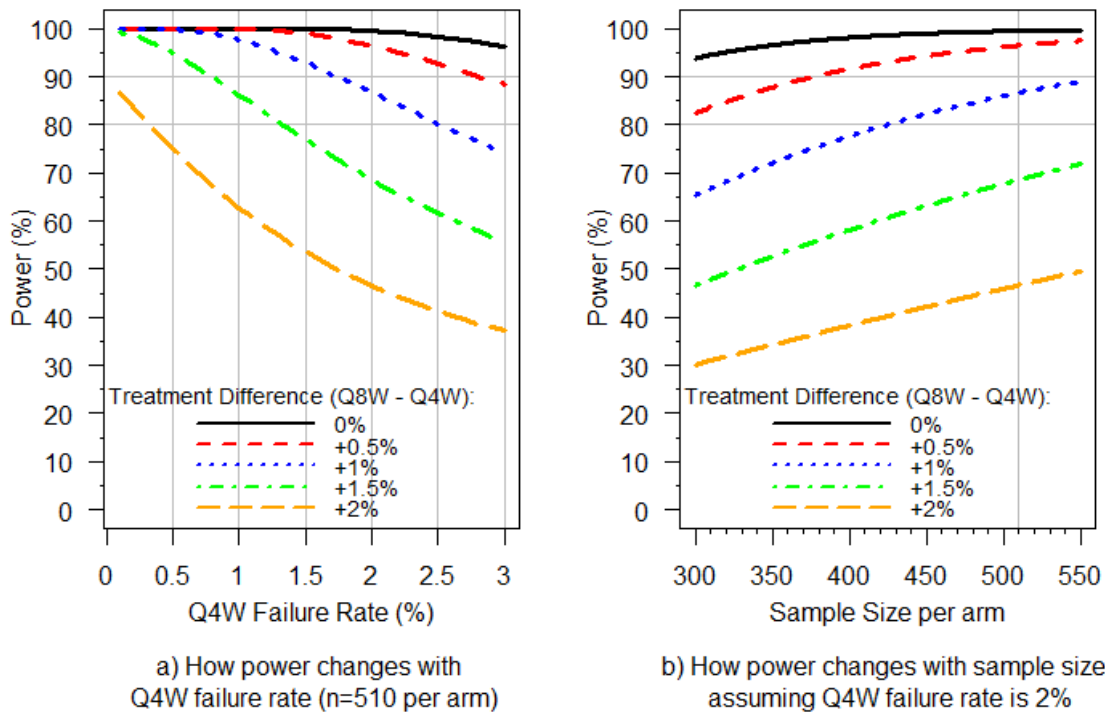
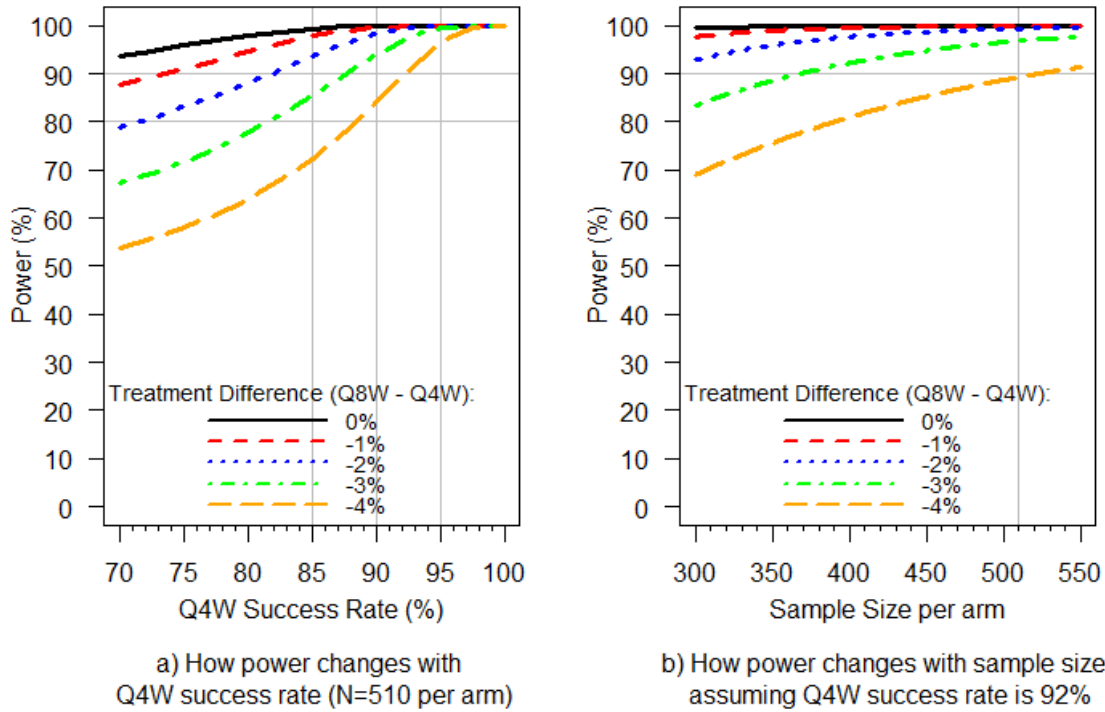

Figure 16a (left panel) shows the sensitivity of the estimated power for the secondary endpoint comparison of response rates (HIV-1 RNA <50 c/mL at Week 48) to different assumed ‘true’ response rates based on calculations using an unpooled Z test statistic and asymptotic approximation. For example, if the true Q8W rate is two percentage points inferior to Q4W (blue line), then power is at least 90% for Q4W rates greater than 82%.

Figure 16b (right panel) shows the impact on power to changes in the sample size assuming an 92% response rate for Q4W. For example, if the true Q8W rate is 3-percentage points inferior to Q4W (green line), then power remains at least 90% for sample sizes as low as 368 per arm.

**Figure 16 Sensitivity of Estimated Power for Snapshot Proportion with HIV-RNA <50 c/mL**



**9.1.5. Sample Size Re-estimation or Adjustment**

No sample-size re-estimation based on response data is planned for this study.

**9.2. Data Analysis Considerations**

**9.2.1. Analysis Populations**

**9.2.1.1. Intent-to-Treat Exposed (ITT-E)**

The ITT-E population will consist of all randomly assigned participants who receive at least one dose of study drug. Participants will be assessed according to their randomized treatment, regardless of the treatment they received. The population used in the primary efficacy analysis will be the ITT-E population.

**9.2.1.2. Per-Protocol Population (PP)**

The Per-Protocol (PP) Population will consist of all participants in the ITT-E Population with the exception of major protocol violators. The PP will be used for sensitivity analysis of the primary endpoint.

**9.2.1.3. PK Population**

The PK Population will include all participants who receive CAB and / or RPV and undergo PK sampling during the study, and provide evaluable CAB and /or

RPV plasma concentration data. Participants in this population will be included in the PK analysis.

#### **9.2.1.4. Safety Population**

The Safety Population will consist of all randomly assigned participants who receive at least one dose of study drug. Participants will be assessed according to actual treatment received. Unless otherwise stated, the Safety Population will be used for safety analyses.

### **9.2.2. Treatment Comparisons**

#### **9.2.2.1. Primary Comparison of Interest**

The primary analysis will be based on the ITT-E population. The primary comparison will be made at a one-sided 2.5% level of significance. Treatment with Q8W will be declared non-inferior to Q4W if the upper end of a two-sided 95% confidence interval for the difference between the two groups (Q8W – Q4W) in the proportion of participants with HIV-RNA  $\geq 50$  c/mL at Week 48 (defined by the US FDA snapshot algorithm) lies below 4%.

#### **9.2.2.2. Other Comparisons of Interest**

- The analysis described above will also be performed using the PP population and the results will be compared for consistency with the results from the ITT-E population. If the primary comparison on interest using the ITT-E population demonstrates non-inferiority of Q8W compared to Q4W then the following key secondary comparisons will be tested: Treatment with Q8W will be declared non-inferior to Q4W with respect to the proportion of participants with HIV-1 RNA < 50 copies/mL at Week 48 (defined by the US FDA snapshot algorithm) if the lower end of a two-sided 95% confidence interval for the difference between in rates (Q8W – Q4W) lies above -10% using the ITT-E population
- Superiority of Q8W compared to Q4W with respect to change from baseline HIVTSQs total score at Week 48 using the ITT-E population and a two-sided 5% level of significance

### **9.2.3. Planned Analyses**

At least 4 analyses will be conducted to evaluate the objectives of the protocol after all subjects have completed their visits at Week 24, Week 48, Week 96, and Week 152 respectively. Further data cuts and analyses may be conducted as necessary in order to support regulatory submissions and publications (first publication at Week 48). The Week 48 analysis will be primary and no results will be shared publicly until Week 48 analysis is complete. Full details for the primary Week 48 analysis (and preliminary Week 24 analysis) will be prespecified in the RAP prior to the database freeze for the Week 24 analysis and sponsor review of any summary of data grouped by actual treatment arm.

### **9.2.3.1. Week 24 data analyses**

An analysis of data through Week 24 will be conducted when all subjects have completed their Week 24 visit, with the intent of expediting submission of results to health authorities.

The analyses described in Section 9.3.2.2, Section 9.3.3 and Section 9.3.6 will be performed. Health outcomes analyses will not be performed.

There is no intention to stop the study early if positive efficacy findings are seen at Week 24 and a formal hypothesis test of non-inferiority at Week 24 will not be evaluated. The analysis at Week 48 is primary and will overrule the findings based on the Week 24 data. Therefore, no multiplicity adjustment to the primary Week 48 treatment comparisons is needed because of the analysis of Week 24 data.

Neither investigators nor subjects will be informed of the results of the Week 24 data analysis. Sponsor staff will only review aggregate data by actual treatment arm after the Week 24 IDMC evaluation is complete as required in the preparation of submission documents.

### **9.2.3.2. IDMC analyses**

Independent review will be provided by an IDMC to ensure external objective medical and/or statistical review of efficacy and safety in order to protect the ethical interests and well-being of subjects and to protect the scientific validity of this study. An ad-hoc review of data by the IDMC will be triggered whenever the number of confirmed virologic failures in the CAB LA + RPV LA Q8W arm exceeds thresholds pre-specified in the IDMC charter. Further, an interim futility analysis will be performed for the IDMC to evaluate the efficacy and safety of CAB LA + RPV LA Q8W arm when approximately 50% of subjects have completed their visit at Week 24; the sponsor will remain blinded to this analysis. Any additional Week 24 analyses will also be shared with the IDMC. Full details of the methods, timing, decision criteria and operating characteristics will be pre-specified in the IDMC Charter.

Since the statistical stopping guidelines will not result in early stopping due to positive efficacy findings for the Q8W regimen, these planned analyses will not inflate the type I error rate for the primary treatment comparison at Week 48.

## **9.3. Key Elements of Analysis Plan**

### **9.3.1. Primary Analyses**

For the primary efficacy analysis, virologic outcome for each participant in the Intent-to-Treat Exposed population will be calculated according to the FDA's Snapshot algorithm. The primary analysis at Week 48 will take place after the last participant has had their Week 48 viral load assessed, including a retest if required.

As defined by the Snapshot algorithm, HIV-RNA  $\geq 50$  copies/mL is determined by the last available HIV-1 RNA measurement while the participant is on treatment within the

analysis visit window of interest. In addition, participants without evaluable HIV-RNA data for the visit of interest and who discontinue from the maintenance phase for reasons not related to adverse event with HIV-1 RNA result at the time of discontinuation  $\geq 50$  copies/mL or who change study treatment not permitted per protocol before the analysis window are classified as having HIV-RNA  $\geq 50$  copies/mL.

For the primary efficacy analysis, the adjusted difference between the randomized arms for the proportion of participants with HIV-1 RNA  $\geq 50$  c/mL at Week 48 (according to the FDA snapshot algorithm) and its confidence interval will be calculated according to a stratified analysis with Cochran-Mantel Haenszel (CMH) weights. This analysis will adjust for the randomization strata (rederived for analysis to correct for stratification errors) according to prior exposure to CAB + RPV (0 weeks, 1-24 weeks, >24 weeks).

The CMH estimate of the common difference in rates across strata will be calculated as the weighted average of the strata-specific estimates of the difference in proportion between the two arms as follows:

- If  $n_k$  is the number of Q8W treated participants,  $m_k$  is the number of Q4W arm treated participants, and  $N_k = n_k + m_k$  is the total number of participants in the  $k$ th stratum, then the CMH estimate is given by

$$\hat{d}_{cmh} = \frac{\sum W_k \hat{d}_k}{\sum W_k}$$

where

$$W_k = \frac{n_k m_k}{N_k}$$

are CMH weights and  $\hat{d}_k$  are estimates of the differences in proportions between the two treatment arms,  $f_{Q8W} - f_{Q4W}$ , for the  $k$ th stratum.

The corresponding two-sided 95% CI will be calculated as:

$$\hat{d}_{cmh} \pm 1.96 \times \sqrt{\widehat{\text{var}}(\hat{d}_{cmh})}$$

using the variance estimator given by [Sato, 1989], which is consistent in both sparse data and large strata. The formula for computing the Sato variance estimate will be provided in the RAP. Non-inferiority will be declared if the upper bound of the two-sided 95% confidence interval for the difference (Q8W – Q4W) is less than 4%.

The weighted least squares chi-squared statistic [Fleiss, 1981] will be used to assess evidence of treatment difference heterogeneity across strata. strata, Following Lui and Kelly [Lui, 2000], 0.50 will be added to each cell in any strata for which the stratum-

specific rate estimates of either  $f_{Q8W}$  or  $f_{Q4W}$  are zero or one. Any heterogeneity found to be statistically significant will be explored. Stratum-specific analyses will also be provided. Investigation of heterogeneity will be confined to the primary endpoint. Tests of homogeneity will be assessed at the one-sided 10% level of significance. Full details will be contained in the RAP.

On-treatment data collected from extra visits within a window will be included in the derivation of the Snapshot response/failure but summary tables using observed case (OC) datasets will only use the data captured closest to the target visit date. Detailed explanations of the derivation of visit windows will be included in the RAP. Any changes to the original analysis plan in the protocol will be described in the RAP and/or clinical study report (CSR).

### **9.3.2. Secondary Analyses**

#### **9.3.2.1. Key Secondary Efficacy Analysis**

A key secondary analysis will evaluate the proportion of participants with HIV-1 RNA  $<50$  c/mL (according to the FDA's Snapshot algorithm) at Week 48 for the ITT-E population. Participants with last available HIV-1 RNA measurement less than 50 copies/mL while the participant is on treatment within the analysis visit window of interest are classified as responders; participants without evaluable HIV-RNA data for the visit of interest or who change treatment not permitted per protocol before the analysis window are considered non-responders. Full details on the Snapshot algorithm for computation of the proportion with HIV-1 RNA  $<50$  copies/mL will be contained in the RAP. The adjusted difference between the randomized arms for the proportions (Q8W – Q4W) and its confidence interval will be calculated according to a stratified analysis with Cochran-Mantel Haenszel (CMH) weights, as described for primary endpoint (Section 9.3.1).

A non-inferiority margin of -10% will be used for this secondary comparison, where if the lower limit of the 95% confidence interval (CI) of the difference between the rates (Q8W – Q4W) is greater than -10%, non-inferiority will be demonstrated.

#### **9.3.2.2. Other Secondary Endpoint Analyses**

The primary analysis (Section 9.3.1) and key secondary efficacy analysis (Section 9.3.2.1) will be repeated at Week 96 and Week 152 with the only difference being a change in time point from Week 48 to Week 96 or Week 152 for determining the snapshot outcomes.

For the Week 24 planned analyses, the adjusted treatment difference in proportion of participants with plasma HIV-1 RNA  $\geq 50$  c/mL (FDA Snapshot algorithm, with 95% confidence interval) at Week 24 will be calculated using the methodology described in Section 9.3.1, but no formal test of non-inferiority will be performed at this early timepoint.

Proportion of participants with plasma HIV-1 RNA  $\geq 50$  c/mL and HIV-1 RNA  $< 50$  c/mL (FDA Snapshot algorithm) at Week 24, Week 48, Week 96, and Week 152 respectively, will be summarized using the Snapshot algorithm for the ITT-E population. Proportion of participants with confirmed virologic failures will also be summarized over time.

Absolute values and change from Baseline in CD4+ lymphocyte count will be summarized over time including Week 48, Week 96, and Week 152.

The proportion of participants with HIV-1 RNA  $\geq 50$  c/mL based on the snapshot algorithm, will be summarized at Week 24, Week 48, Week 96, and Week 152 by duration of prior CAB + RPV exposure (0 weeks, 1-24 weeks,  $> 24$  weeks),

The proportion of participants with HIV-1 RNA  $< 50$  c/mL based on snapshot algorithm, will be summarized at Week 48, Week 96, and Week 152 by duration of prior CAB + RPV exposure (0 weeks, 1-24 weeks,  $> 24$  weeks).

An observed case dataset, with no imputation for missing data, will be the primary dataset used for analysis of safety endpoints.

The proportion of participants reporting AEs will be tabulated for each treatment group. The following summaries of AEs will be provided:

- Incidence and severity of all AEs
- Incidence and severity of treatment related AEs
- Incidence and severity of AEs leading to withdrawal
- Incidence of SAEs

Changes from baseline in laboratory will be summarized by visit and treatment group including Week 48, Week 96, and Week 152. In addition, the number and percentage of participants with graded laboratory toxicities (based on DAIDS categories) will be summarized by treatment group.

Further details for secondary efficacy, safety, and exploratory endpoint analyses will be included in the RAP.

### **9.3.3. Pharmacokinetic Analyses**

The GSK Division of Clinical Pharmacology Modeling and Simulation (CPMS) will be responsible for the PK analysis of CAB. The Division of Clinical Pharmacology Development at Janssen Research and Development will be responsible for conduct or oversight of the PK analysis for RPV.

Actual sampling and dosing times as recorded in the eCRF will be used for analysis.

Plasma CAB and RPV concentration data will be listed and summarized by week, day, and planned sampling time in both tabular and graphical forms. A composite predose (C0) concentration may be estimated for purposes of PK/PD analysis. Post hoc estimates of PK parameters will be determined by population PK modeling separately (see Population PK Analysis below).

#### **9.3.4. Population PK Analysis:**

CAB LA and RPV LA population PK models will be constructed separately and individual Bayesian PK parameter estimates may be obtained, if the quality of the data permits. Data from this study may be merged with previous data to support the model building process. Sources of variability in pharmacokinetic parameters will be investigated during population modeling. Demographic parameters including, but not limited to age, gender, ethnic origin, body size (weight, height, body surface area, body mass index), and relevant laboratory parameters will be evaluated as potential predictors of inter- and intra-participant variability for pharmacokinetic parameters. Population pharmacokinetic modeling will be performed using the non-linear mixed effects software NONMEM (ICON; Hanover, MD). Further details of population pharmacokinetic analyses will be described in a separate RAP. Population PK analyses will be done under separate Population-PK Reporting and Analysis Plans, and post hoc PK parameters may be determined.

#### **9.3.5. Pharmacokinetic/Pharmacodynamic Analyses**

Relationships between various plasma CAB LA and/or RPV LA PK parameters and pharmacodynamic measures (e.g., HIV-1 RNA, or safety measures) may be explored using simple correlation analyses or population-based PK/PD approach. Additional factors that may be considered include; e.g., age, weight, BMI, gender, race, Baseline HIV-1 RNA, HIV risk factors, CDC HIV-1 stage, and CD4+ cell count.

Exploratory analyses will be performed to examine the relationship(s) between plasma concentrations of CAB and RPV and pharmacodynamic endpoints. A population pharmacokinetic/pharmacodynamic modeling approach may be further applied to model the data using the nonlinear mixed effect modeling software, NONMEM (ICON LLC, Hanover, MD). Details of the PK/PD analyses plans for CAB and / or RPV will be provided in separate RAPs.

#### **9.3.6. Viral Genotyping/Phenotyping Analyses**

The incidence of treatment emergent genotypic and phenotypic resistance to NRTIs and INIs, PIs, and NNRTIs and in particular to current antiretroviral regimen and to CAB or RPV will be summarized by treatment arm for subjects meeting confirmed virologic failure criteria. Limited analyses will be conducted for Week 24 planned analyses. Details of the analyses to be performed will be specified in the reporting and analysis plan (RAP).

#### **9.3.7. Health Outcomes Analyses**

Details of the analyses to be performed for the endpoints described in Section 7.8 will be specified in the reporting and analysis plan. Participant preference for CAB LA + RPV LA every 8 weeks or CAB LA + RPV LA every 4 weeks compared to oral ARV regimen, and preference for CAB LA + RPV LA every 4 weeks compared to CAB LA + RPV LA every 8 weeks will be a key secondary treatment analysis based on the ITT-E population. As another key secondary treatment comparison, superiority of Q8W compared to Q4W



with respect to change from baseline in HIVTSQs total score at Week 48 will be tested at a two-sided 5% significance level using a linear model based on the ITT-E population.

### **9.3.8. Genetic Analyses**

See the full protocol for details about the Genetics Analysis Plan.

### **9.3.9. Other Analyses**

Planned subgroup analyses include: proportion of participants by patient subgroup(s) (e.g., by age, gender, BMI, race, HIV-1 subtype, Baseline CD4+, type of oral treatment [NNRTI, PI, or INSTI], duration prior CAB LA and RPV LA exposure [0 weeks, 1-24 weeks, >24 weeks]) with HIV-1 RNA  $\geq 50$  c/mL over time including Week 48, Week 96, and Week 152.

In addition, stratum-specific analyses (unadjusted treatment difference and corresponding 95% confidence interval) of the primary endpoint (proportion of participants with HIV-1 RNA  $\geq 50$  c/mL) and key secondary endpoint (proportion of participants with HIV-1 RNA  $< 50$  c/mL) at Week 48 (Week 96, and Week 152) will be performed within each of the following patient populations: (*Group 1*) those currently receiving *Standard of Care antiretroviral therapy [no prior CAB + RPV exposure]* and (*Group 2*) those receiving *Q4W CAB LA + RPV LA therapy in the ongoing ATLAS study*). For Group 2, a stratum-adjusted analysis will also be provided, with adjustment for prior CAB + RPV exposure (1 to 24 weeks vs. >24 weeks) using Cochran-Mantel Haenszel (CMH) weights, as described in Section 9.3.1.

Changes from baseline in CD4+ lymphocyte count at Week 48, Week 96, and Week 152 will also be summarized by subgroups. Additional details on subgroup analyses will be provide in the RAP.

Further details of exploratory analyses will be presented in the RAP.

## 10. REFERENCES

- Andrade RJ, Robles M, Lucena MI. Rechallenge in drug-induced liver injury: the attractive hazard. *Expert Opin Drug Saf.* 2009; 8:709-714.
- Antiretroviral Therapy Cohort Collaboration (ART-CC). Durability of first ART regimen and risk factors for modification, interruption or death in HIV-positive patients starting ART in Europe and North America 2002-2009. *AIDS* 2013; 27:803-813.
- Arribas J, Clumeck N, Nelson M, Hill A, van Delft Y, Moecklingoff C. The MONET trial: week 144 analysis of the efficacy of darunavir/ritonavir (DRV/r) monotherapy versus DRV/r plus two nucleoside reverse transcriptase inhibitors, for patients with viral load <50 copies/ml at baseline. *HIV MED*, 2012: Aug;13(7):398-405.
- Arribas J, Girard P, Landman R, Rich J, Mallolas J, Martinez-Rebollar M, et al. Dual treatment with lopinavir-ritonavir plus lamivudine versus triple treatment with lopinavir-ritonavir plus lamivudine or emtricitabine and a second nucleos(t)ide reverse transcriptase inhibitor. *Lancet Infect Dis.*, 2015; 15:785-92.
- Bierman WF, van Aqtaamael MA, Nijhuis M, Danner SA, Boucher CA. HIV monotherapy with ritonavir-boosted protease inhibitors: a systematic review. *AIDS*, 2009; 23(3):279-91.
- British HIV Association (BHIVA) guidelines for the treatment of HIV-1-infected adults with antiretroviral therapy 2015 [2016 interim update]. Available at: <http://www.bhiva.org/documents/Guidelines/Treatment/2016/treatment-guidelines-2016-interim-update.pdf>. Accessed 18 June 2017.
- Centers for Disease Control and Prevention (CDC) Revised surveillance case definition for HIV infection-United States, 2014. *MMWR Recomm Rep* 2014;63 (RR-03):1-10.
- Chevat C, Viala-Danten M, Dias-Barbosa C, Nguyen VH. Development and psychometric validation of a self-administered questionnaire assessing the acceptance of influenza vaccination: the Vaccinees' Perception of Injection (VAPI©) questionnaire. *Health Qual Life Outcomes.* 2009;7:21.
- Department of Health and Human Services (DHHS). Panel on Antiretroviral Guidelines for Adults and Adolescents. Guidelines for the use of antiretroviral agents in HIV-1-infected adults and adolescents. Updated July 14, 2016. Available at: <https://aidsinfo.nih.gov/contentfiles/lvguidelines/adultandadolescentgl.pdf> Accessed 18 June 2017.
- Department of Health and Human Services, Food and Drug Administration FDA, Center for Drug Evaluation and Research (US). Guidance for Industry. Human Immunodeficiency Virus-1 Infection: Developing Antiretroviral Drugs for Treatment, Revision 1, November 2015. Available at: <https://www.fda.gov/downloads/drugs/guidancecomplianceregulatoryinformation/guidances/ucm355128.pdf>. Accessed: 16 Jun 2017.

Dube MP, Stein JH, Aberg JA, Fichtenbaum CJ, Gerber JG, Tashima KT et al. Guidelines for the evaluation and management of dyslipidemia in human immunodeficiency virus (HIV)-infected adults receiving antiretroviral therapy: recommendations of the HIV Medical Association of the Infectious Disease Society of America and the Adult AIDS Clinical Trials Group. *Clin Infect Dis* 2003; 37(5):613-27.

European AIDS Clinical Society (EACS) Guidelines, Version 8.2, January 2017. Available at: [http://www.eacsociety.org/files/guidelines\\_8.2-english.pdf](http://www.eacsociety.org/files/guidelines_8.2-english.pdf). Accessed 18 June 2017

Fleiss JL. *Statistical Methods for Rates and Proportions*. 2nd ed. New York:John Wiley; 1981.

GlaxoSmithKline Document Number 2011N112455\_03: LAI115428: A Randomized, Open Label Study to Investigate the Safety, Tolerability and Pharmacokinetics of Repeat Dose Administration of Long-Acting GSK1265744 and Long-Acting TMC278 Intramuscular and Subcutaneous Injections in Healthy Adult. Effective Date: 04Feb2013.

GlaxoSmithKline Document Number 2011N130484\_00: LAI116181: A Phase 1, Open-Label, Crossover Study to Evaluate the Pharmacokinetics and Safety of GSK1265744 and Rilpivirine and Dolutegravir and Rilpivirine in Healthy Adult Participants. Effective Date: 18Jul2012.

GlaxoSmithKline Document Number 2013N168152\_05: 20056: A Phase IIb Study Evaluating a Long-Acting Intramuscular Regimen of GSK1265744 plus TMC278 For The Maintenance of Virologic Suppression Following an Induction of Virologic Suppression on an Oral regimen of GSK1265744 plus Abacavir/Lamivudine in HIV-1 Infected, Antiretroviral Therapy- Naive Adult Subjects. Effective Date: 13Jun2014.

GlaxoSmithKline Document Number 2014N216014\_00: LAI116482: A Phase IIb, Dose Ranging Study of Oral GSK1265744 in Combination with Nucleoside Reverse Transcriptase Inhibitors for Induction of HIV-1 Virologic Suppression Followed by an Evaluation of Maintenance of Virologic Suppression when Oral GSK1265744 is Combined with Oral Rilpivirine in HIV-1 Infected, Antiretroviral Therapy Naive Adult Participants - Week 96 Results. Effective Date 02Sept2015.

GlaxoSmithKline Document Number 2016N269422\_00: 201120: A Phase IIa Study to Evaluate the Safety, Tolerability and Acceptability of Long Acting Injections of the HIV Integrase Inhibitor, GSK1265744, in HIV Uninfected Men (ÉCLAIR) –Week 81 Results. Effective Date: 25Oct2016.

Holmes WC, Shea JA. A new HIV/AIDS-targeted quality of life (HAT-QoL) instrument: development, reliability, and validity. *Med Care*. 1998 Feb;36(2):138-54.

Hunt CM, *Contraceptive Technology*. 20th edition. Atlanta, Georgia: Ardent Media, Inc., 2011: 50. Table 3-2. *Hepatology* 2010; 52:2216-2222.

ICH E2A: International Conference on Harmonisation Tripartite Guideline: Clinical Safety Data Management: Definitions and Standards for Expedited Reporting (1994)

International AIDS Society (IAS) Antiretroviral Drugs for Treatment and Prevention of HIV Infection in Adults. 2016 Recommendations of the International Antiviral Society-USA Panel. Günthard HF, Saag MS, Benson CA, et al. *JAMA*. 2016; 316:191-210.

International AIDS Society (IAS) Guidelines - Update of the Drug Resistance Mutations in HIV-1: Oct/Nov 2015. *Topics in Antiviral Medicine*; 23(4): available online ahead of print at [http://www.iasusa.org/sites/default/files/tam/2015hiv\\_muta\\_article.pdf](http://www.iasusa.org/sites/default/files/tam/2015hiv_muta_article.pdf).

James LP, Letzig L, Simpson PM, Capparelli E, Roberts DW, Hinson JA et al. Pharmacokinetics of acetaminophen-protein adducts in adults with acetaminophen overdose and acute liver failure. *Drug Metab Dispos* 2009;37(8):1779-1784.

Levey AS, Stevens LA, Schmid CH, Zhang YL, Castro AF, Feldman HI, et.al. A new equation to estimate glomerular filtration rate. *Ann Int Med*. 2009; 150: 604-12.

Lui KJ, Kelly C. A revisit on tests for the homogeneity of the risk difference. *Biometrics*. 2000; 56: 309-315.

Marant C, Longin J, Gauchoux R, Arnould B, Spizak C, Marrel A, et al. Long-term treatment acceptance: what is it, and how can it be assessed? *Patient*. 2012;5(4):239-49.

Margolis D, Brinson C, Smith G, de Vente J, Hagins D, Eron J, et. al. Cabotegravir plus rilpivirine, once a day, after induction with cabotegravir plus nucleoside reverse transcriptase inhibitors in antiretroviral-naïve adults with HIV-1 infection (LATTE): a randomised, phase 2b, dose-ranging trial. *Lancet Infect Dis*. 2015; 15: 1145-55.

McGowan I, Siegel A, Engstrom J, et al. Persistence of rilpivirine following single dose of long-acting injection. 21st International AIDS Conference (AIDS 2016). July 18-22, 2016. Durban, South Africa. Abstract TUAC0103.

Papay JJ, Clines D, Rafi R, et al. Drug-induced liver injury following positive drug rechallenge. *Regul Tox Pharm*. 2009; 54:84-90.

Posner K, Oquendo MA, Gould M, Stanley B, Davies M. Columbia Classification Algorithm of Suicide Assessment (C-CASA): classification of suicidal events in the FDA's pediatric suicidal risk analysis of antidepressants. *Am J Psychiatry*. 2007;164:1035-1043.

Sato T, Greenland S, Robins JM. On the variance estimator for the Mantel-Haenszel risk difference. *Biometrics*.1989;45:1323-1324.

UNAIDS, 2016, Geneva Switzerland, *AIDS Data*

Woodcock A, Bradley C. Validation of the HIV Treatment Satisfaction QUestionnaire (HIVTSQ). *Quality of Life Research*. 2001: 10, 517-531.

Woodcock, A, Bradley C . Validation of the revised 10-item HIV Treatment Satisfaction Questionnaire status version (HIVTSQs) and the new change version (HIVTSQc). *Value in Health*,2006: 9(5) 320-333.

## 11. APPENDICES

### 11.1. Appendix 1: Abbreviations and Trademarks

#### Abbreviations

3TC	Lamivudine, EPIVIR
ABC	Abacavir, ZIAGEN
ABC/3TC	Abacavir/lamivudine, EPZICOM, KIVEXA
ABC/DTG/3TC	Abacavir/dolutegravir/lamivudine, TRIUMEQ
ACCEPT	General acceptance” dimension of the Chronic Treatment Acceptance
ADE	Adverse device effect
ADR	Adverse drug reaction
AE	Adverse event
AIDS	Acquired immunodeficiency syndrome
ALT	Alanine aminotransferase
Anti-HBc	Hepatitis B core Antibody
Anti-HbsAg	Antibodies against Hepatitis B surface Antigen
APAP	N-acetyl-para-aminophenol
APR	Antiretroviral Pregnancy Registry
ARV	Antiretroviral
ART	Antiretroviral therapy
ATV	Atazanavir
ATLAS	Antiretroviral Therapy as Long Acting Suppression every 2 Months
AST	Aspartate aminotransferase
AUC	Area under the curve
AUC(0- $\tau$ )	Area under the concentration curve from 0 hours to the time of next dosing
BP	Blood Pressure
BUN	Blood Urea Nitrogen
CAB	Cabotegravir
CAB LA	Cabotegravir long-acting
c/mL	Copies/milliliter
cART	Combination antiretroviral therapy
CD4	Cluster of Differentiation 4
CD8	Cluster of Differentiation 8
CDC	Centers for Disease Control and Prevention
CFR	Code of federal regulation
CKD-EPI	Chronic Kidney Disease Epidemiology Collaboration
C <sub>max</sub>	Maximum concentration
CMH	Cochran-Mantel Haenszel
ConART	Concomitant Antiretroviral Therapy
CSR	Clinical Study Report
C-SSRS	Columbia Suicidality Severity Rating Scale

CI	Confidence interval
CONSORT	Consolidated Standards of Reporting Trials
CPK	Creatine phosphokinase
CPMS	Clinical Pharmacology Modelling and Simulation
CSR	Clinical Study Report
CV	Cardiovascular
CVF	Confirmed Virologic Failure
DAIDS	Division of Acquired Immunodeficiency Syndrome
DILI	Drug induced liver injury
DNA	Deoxyribonucleic acid
DRE	Disease-Related Events
DRV	Darunavir
DTG	Dolutegravir, TIVICAY
DVT	Deep vein thrombosis
ECG	Electrocardiogram
eC-SSRS	Columbia Suicide Severity Rating Scale
eCRF	Electronic case report form
EFV	Efavirenz
eGFR	Estimated glomerular filtration rate
EMA	European Medicines Agency
EQ-5D-5L	European Quality of Life-5 Dimensions-5 Levels
ETR	Etravirine
EU	European Union
EVG	Elvitegravir
FDA	Food and Drug Administration
FDC	Fixed-dose combination
FRP	Females of Reproductive Potential
FSH	Follicle Stimulating hormone
FTC	Emtricitabine
GCP	Good Clinical Practice
GSK	GlaxoSmithKline
HAART	Highly active antiretroviral therapy
HbsAg	Hepatitis B surface Antigen
HAT-QoL	HIV/AIDS-targeted quality of life
HBV	Hepatitis B virus
HCG	human chorionic gonadotrophin
HCV	Hepatitis C virus
HCP	Health Care Provider
HDL	High density lipoprotein
HDPE	High density polyethylene
HIV	Human immunodeficiency virus
HIV TSQ	HIV treatment satisfaction questionnaire
HLA	Human leukocyte antigen
HRT	Hormone Replacment Therapy
HSR	Hypersensitivity reaction
IAS	International AIDS Society

IB	Investigator's Brochure
ICH	International Conference on Harmonisation
IDFU	Investigational directions for use
IDMC	Independent data monitoring committee
IEC	Independent Ethics Committee
IgM	Immunoglobulin M
IM	Intramuscular
INH	Isoniazid
INI	Integrase inhibitor
INR	International normalized ratio
INSTI	Integrase strand transfer inhibitor
IP	Investigational Product
IRB	Institutional Review Board
ITT-E	Intent-to-treat exposed
IUD	Intrauterine device
IRT	Interactive response technology
ISR	Injection Site Reaction
LA	Long Acting
LDL	Low density lipoprotein
LPV	Lopinavir
LPV/r	Lopinavir-ritonavir
LTFU	Long-Term Follow-UP
MACDP	Metropolitan Atlanta Congenital Defects Program
MCV	Mean corpuscular volume
MedDRA	Medical dictionary for regulatory activities
Mg	Milligram
Mg/dL	Milligram
MSD=F	Missing, switch, or discontinuation equals failure
NNRTI	Non-nucleoside reverse transcriptase inhibitor
NRS	Numeric Rating Scale
NRTI	Nucleoside reverse transcriptase inhibitor
NTD	Neural Tube Defect
PI	Protease inhibitor
PIN	Perception of Injection
PK	Pharmacokinetic
PP	Per-protocol
PRO	Protease
PRTD	Proximal Renal Tubule Dysfunction
PSRAE	Possible suicidality-related adverse event
PTCA	Percutaneous transluminal coronary angioplasty
QTc	Corrected QT interval
Q8W	Every 8 weeks
Q4W	Every 4 weeks
RAL	Raltegravir
RAP	Reporting and Analysis Plan



RBC	Red blood cell
RBP	Retinol Binding Protein
RNA	Ribonucleic acid
RPR	Rapid plasma reagin
RPV	Rilpivirine, Edurant
RPV LA	Rilpivirine long-acting
RT	Reverse transcriptase
RTV	Ritonavir
SAE	Serious adverse event
SJS	Stevens-Johnson syndrome
SOC	Standard of Care
SPM	Study Procedures Manual
STR	Single tablet regimen
SVW	Suspected Virologic Withdrawal
TDF	Tenofovir disoproxil fumarate
TEN	Toxic epidermal necrolysis
TMC278	Tibotec Medicinal Compound 278
TSQ	Treatment Satisfaction Questionnaire
ULN	Upper limit of normal
US	United States
VAPI	Vaccines' Perception of Injection
VAS	Visual Analog Scale
VSLC	ViiV Safety and Labeling Committee
WBC	White blood cell

### Trademark Information

Trademarks of ViiV Healthcare
CABENUVA
EPIVIR
EPZICOM/KIVEXA
TIVICAY
TRIUMEQ
ZIAGEN

Trademarks not owned by ViiV Healthcare
Edurant
Genosure
InForm
MedDRA
Monogram Biosciences
NONMEN
PhonoSense
RAMOS NG
RANDALL NG
TRIZIVIR

**11.2. Appendix 2: Division of AIDS Table for Grading the Severity of Adult and Pediatric Adverse Events Version 2.1, March 2017**

The Division of AIDS Table for Grading the Severity of Adult and Pediatric Adverse Events (“DAIDS AE Grading Table”) is a descriptive terminology which can be utilised for Adverse Event (AE) reporting. A grading (severity) scale is provided for each AE term.

**Estimating Severity Grade for Parameters Not Identified in the Grading Table**

The functional table below should be used to grade the severity of an AE that is not specifically identified in the grading table. In addition, all deaths related to an AE are to be classified as grade 5.

PARAMETER	GRADE 1 MILD	GRADE 2 MODERATE	GRADE 3 SEVERE	GRADE 4 POTENTIALLY LIFE-THREATENING
Clinical adverse event <b>NOT</b> identified elsewhere in the grading table	Mild symptoms causing no or minimal interference with usual social & functional activities with intervention not indicated	Moderate symptoms causing greater than minimal interference with usual social & functional activities with intervention indicated	Severe symptoms causing inability to perform usual social & functional activities with intervention or hospitalization indicated	Potentially life-threatening symptoms causing inability to perform basic self-care functions with intervention indicated to prevent permanent impairment, persistent disability, or death

## Major Clinical Conditions

### Cardiovascular

PARAMETER	GRADE 1 MILD	GRADE 2 MODERATE	GRADE 3 SEVERE	GRADE 4 POTENTIALLY LIFE- THREATENING
<b>Arrhythmia</b> (by ECG or physical examination) <i>Specify type, if applicable</i>	No symptoms <u>AND</u> No intervention indicated	No symptoms <u>AND</u> Non-urgent intervention indicated	Non-life-threatening symptoms <u>AND</u> Non-urgent intervention indicated	Life-threatening arrhythmia <u>OR</u> Urgent intervention indicated
<b>Blood Pressure Abnormalities<sup>1</sup></b> <i>Hypertension (with the lowest reading taken after repeat testing during a visit) ≥ 18 years of age</i>	140 to < 160 mmHg systolic <u>OR</u> 90 to < 100 mmHg diastolic	≥ 160 to < 180 mmHg systolic <u>OR</u> ≥ 100 to < 110 mmHg diastolic	≥ 180 mmHg systolic <u>OR</u> ≥ 110 mmHg diastolic	Life-threatening consequences in a participant not previously diagnosed with hypertension (e.g., malignant hypertension) <u>OR</u> Hospitalization indicated
<i>&lt; 18 years of age</i>	> 120/80 mmHg	≥ 95 <sup>th</sup> to < 99 <sup>th</sup> percentile + 5 mmHg adjusted for age, height, and gender (systolic and/or diastolic)	≥ 99 <sup>th</sup> percentile + 5 mmHg adjusted for age, height, and gender (systolic and/or diastolic)	Life-threatening consequences in a participant not previously diagnosed with hypertension (e.g., malignant hypertension) <u>OR</u> Hospitalization indicated
<b>Hypotension</b>	No symptoms	Symptoms corrected with oral fluid replacement	Symptoms <u>AND</u> IV fluids indicated	Shock requiring use of vasopressors or mechanical assistance to maintain blood pressure
<b>Cardiac Ischemia or Infarction</b> <i>Report only one</i>	NA	NA	New symptoms with ischemia (stable angina) <u>OR</u> New testing consistent with ischemia	Unstable angina <u>OR</u> Acute myocardial infarction
<b>Heart Failure</b>	No symptoms <u>AND</u> Laboratory or cardiac imaging abnormalities	Symptoms with mild to moderate activity or exertion	Symptoms at rest or with minimal activity or exertion (e.g., hypoxemia) <u>OR</u> Intervention indicated (e.g., oxygen)	Life-threatening consequences <u>OR</u> Urgent intervention indicated (e.g., vasoactive medications, ventricular assist device, heart transplant)

<sup>1</sup> Blood pressure norms for children < 18 years of age can be found in: Expert Panel on Integrated Guidelines for Cardiovascular Health and Risk Reduction in Children and Adolescents. *Pediatrics* 2011;128;S213; originally published online November 14, 2011; DOI: 10.1542/peds.2009-2107C.

## Cardiovascular

PARAMETER	GRADE 1 MILD	GRADE 2 MODERATE	GRADE 3 SEVERE	GRADE 4 POTENTIALLY LIFE- THREATENING
<b>Hemorrhage</b> (with significant acute blood loss)	NA	Symptoms <u>AND</u> No transfusion indicated	Symptoms <u>AND</u> Transfusion of $\leq 2$ units packed RBCs indicated	Life-threatening hypotension <u>OR</u> Transfusion of $> 2$ units packed RBCs (for children, packed RBCs $> 10$ cc/kg) indicated
<b>Prolonged PR Interval or AV Block</b> <i>Report only one</i> <i>&gt; 16 years of age</i>	PR interval 0.21 to $< 0.25$ seconds	PR interval $\geq 0.25$ seconds <u>OR</u> Type I 2 <sup>nd</sup> degree AV block	Type II 2 <sup>nd</sup> degree AV block <u>OR</u> Ventricular pause $\geq 3.0$ seconds	Complete AV block
<i><math>\leq 16</math> years of age</i>	1 <sup>st</sup> degree AV block (PR interval $>$ normal for age and rate)	Type I 2 <sup>nd</sup> degree AV block	Type II 2 <sup>nd</sup> degree AV block <u>OR</u> Ventricular pause $\geq 3.0$ seconds	Complete AV block
<b>Prolonged QTc Interval<sup>2</sup></b>	0.45 to 0.47 seconds	$> 0.47$ to 0.50 seconds	$> 0.50$ seconds <u>OR</u> $\geq 0.06$ seconds above baseline	Life-threatening consequences (e.g., Torsade de pointes, other associated serious ventricular dysrhythmia)
<b>Thrombosis or Embolism</b> <i>Report only one</i>	NA	Symptoms <u>AND</u> No intervention indicated	Symptoms <u>AND</u> Intervention indicated	Life-threatening embolic event (e.g., pulmonary embolism, thrombus)

<sup>2</sup> As per Bazett's formula.

## Dermatologic

PARAMETER	GRADE 1 MILD	GRADE 2 MODERATE	GRADE 3 SEVERE	GRADE 4 POTENTIALLY LIFE- THREATENING
<b>Alopecia</b> (scalp only)	Detectable by study participant, caregiver, or physician <u>AND</u> Causing no or minimal interference with usual social & functional activities	Obvious on visual inspection <u>AND</u> Causing greater than minimal interference with usual social & functional activities	NA	NA
<b>Bruising</b>	Localized to one area	Localized to more than one area	Generalized	NA
<b>Cellulitis</b>	NA	Non-parenteral treatment indicated (e.g., oral antibiotics, antifungals, antivirals)	IV treatment indicated (e.g., IV antibiotics, antifungals, antivirals)	Life-threatening consequences (e.g., sepsis, tissue necrosis)
<b>Hyperpigmentation</b>	Slight or localized causing no or minimal interference with usual social & functional activities	Marked or generalized causing greater than minimal interference with usual social & functional activities	NA	NA
<b>Hypopigmentation</b>	Slight or localized causing no or minimal interference with usual social & functional activities	Marked or generalized causing greater than minimal interference with usual social & functional activities	NA	NA
<b>Petechiae</b>	Localized to one area	Localized to more than one area	Generalized	NA
<b>Pruritus</b> <sup>3</sup> (without skin lesions)	Itching causing no or minimal interference with usual social & functional activities	Itching causing greater than minimal interference with usual social & functional activities	Itching causing inability to perform usual social & functional activities	NA
<b>Rash</b> <i>Specify type, if applicable</i>	Localized rash	Diffuse rash <u>OR</u> Target lesions	Diffuse rash <u>AND</u> Vesicles or limited number of bullae or superficial ulcerations of mucous membrane limited to one site	Extensive or generalized bullous lesions <u>OR</u> Ulceration of mucous membrane involving two or more distinct mucosal sites <u>OR</u> Stevens-Johnson syndrome <u>OR</u> Toxic epidermal necrolysis

<sup>3</sup> For pruritus associated with injections or infusions, see the *Site Reactions to Injections and Infusions* section

## Endocrine and Metabolic

PARAMETER	GRADE 1 MILD	GRADE 2 MODERATE	GRADE 3 SEVERE	GRADE 4 POTENTIALLY LIFE- THREATENING
Diabetes Mellitus	Controlled without medication	Controlled with medication <u>OR</u> Modification of current medication regimen	Uncontrolled despite treatment modification <u>OR</u> Hospitalization for immediate glucose control indicated	Life-threatening consequences (e.g., ketoacidosis, hyperosmolar non-ketotic coma, end organ failure)
Gynecomastia	Detectable by study participant, caregiver, or physician <u>AND</u> Causing no or minimal interference with usual social & functional activities	Obvious on visual inspection <u>AND</u> Causing pain with greater than minimal interference with usual social & functional activities	Disfiguring changes <u>AND</u> Symptoms requiring intervention or causing inability to perform usual social & functional activities	NA
Hyperthyroidism	No symptoms <u>AND</u> Abnormal laboratory value	Symptoms causing greater than minimal interference with usual social & functional activities <u>OR</u> Thyroid suppression therapy indicated	Symptoms causing inability to perform usual social & functional activities <u>OR</u> Uncontrolled despite treatment modification	Life-threatening consequences (e.g., thyroid storm)
Hypothyroidism	No symptoms <u>AND</u> Abnormal laboratory value	Symptoms causing greater than minimal interference with usual social & functional activities <u>OR</u> Thyroid replacement therapy indicated	Symptoms causing inability to perform usual social & functional activities <u>OR</u> Uncontrolled despite treatment modification	Life-threatening consequences (e.g., myxedema coma)
Lipoatrophy <sup>4</sup>	Detectable by study participant, caregiver, or physician <u>AND</u> Causing no or minimal interference with usual social & functional activities	Obvious on visual inspection <u>AND</u> Causing greater than minimal interference with usual social & functional activities	Disfiguring changes	NA

<sup>4</sup> Definition: A disorder characterized by fat loss in the face, extremities, and buttocks.

## Endocrine and Metabolic

PARAMETER	GRADE 1 MILD	GRADE 2 MODERATE	GRADE 3 SEVERE	GRADE 4 POTENTIALLY LIFE- THREATENING
Lipohypertrophy <sup>5</sup>	Detectable by study participant, caregiver, or physician <u>AND</u> Causing no or minimal interference with usual social & functional activities	Obvious on visual inspection <u>AND</u> Causing greater than minimal interference with usual social & functional activities	Disfiguring changes	NA

<sup>5</sup> Definition: A disorder characterized by abnormal fat accumulation on the back of the neck, breasts, and abdomen.

## Gastrointestinal

PARAMETER	GRADE 1 MILD	GRADE 2 MODERATE	GRADE 3 SEVERE	GRADE 4 POTENTIALLY LIFE- THREATENING
<b>Anorexia</b>	Loss of appetite without decreased oral intake	Loss of appetite associated with decreased oral intake without significant weight loss	Loss of appetite associated with significant weight loss	Life-threatening consequences <u>OR</u> Aggressive intervention indicated (e.g., tube feeding, total parenteral nutrition)
<b>Ascites</b>	No symptoms	Symptoms <u>AND</u> Intervention indicated (e.g., diuretics, therapeutic paracentesis)	Symptoms recur or persist despite intervention	Life-threatening consequences
<b>Bloating or Distension</b> <i>Report only one</i>	Symptoms causing no or minimal interference with usual social & functional activities	Symptoms causing greater than minimal interference with usual social & functional activities	Symptoms causing inability to perform usual social & functional activities	NA
<b>Cholecystitis</b>	NA	Symptoms <u>AND</u> Medical intervention indicated	Radiologic, endoscopic, or operative intervention indicated	Life-threatening consequences (e.g., sepsis, perforation)
<b>Constipation</b>	NA	Persistent constipation requiring regular use of dietary modifications, laxatives, or enemas	Obstipation with manual evacuation indicated	Life-threatening consequences (e.g., obstruction)
<b>Diarrhea</b> <i>≥ 1 year of age</i>	Transient or intermittent episodes of unformed stools <u>OR</u> Increase of ≤ 3 stools over baseline per 24-hour period	Persistent episodes of unformed to watery stools <u>OR</u> Increase of 4 to 6 stools over baseline per 24-hour period	Increase of ≥ 7 stools per 24-hour period <u>OR</u> IV fluid replacement indicated	Life-threatening consequences (e.g., hypotensive shock)
<i>&lt; 1 year of age</i>	Liquid stools (more unformed than usual) but usual number of stools	Liquid stools with increased number of stools <u>OR</u> Mild dehydration	Liquid stools with moderate dehydration	Life-threatening consequences (e.g., liquid stools resulting in severe dehydration, hypotensive shock)
<b>Dysphagia or Odynophagia</b> <i>Report only one and specify location</i>	Symptoms but able to eat usual diet	Symptoms causing altered dietary intake with no intervention indicated	Symptoms causing severely altered dietary intake with intervention indicated	Life-threatening reduction in oral intake
<b>Gastrointestinal Bleeding</b>	Not requiring intervention other than iron supplement	Endoscopic intervention indicated	Transfusion indicated	Life-threatening consequences (e.g., hypotensive shock)



## Gastrointestinal

PARAMETER	GRADE 1 MILD	GRADE 2 MODERATE	GRADE 3 SEVERE	GRADE 4 POTENTIALLY LIFE- THREATENING
<b>Mucositis or Stomatitis</b> <i>Report only one and specify location</i>	Mucosal erythema	Patchy pseudomembranes or ulcerations	Confluent pseudomembranes or ulcerations <u>OR</u> Mucosal bleeding with minor trauma	Life-threatening consequences (e.g., aspiration, choking) <u>OR</u> Tissue necrosis <u>OR</u> Diffuse spontaneous mucosal bleeding
<b>Nausea</b>	Transient (< 24 hours) or intermittent <u>AND</u> No or minimal interference with oral intake	Persistent nausea resulting in decreased oral intake for 24 to 48 hours	Persistent nausea resulting in minimal oral intake for > 48 hours <u>OR</u> Rehydration indicated (e.g., IV fluids)	Life-threatening consequences (e.g., hypotensive shock)
<b>Pancreatitis</b>	NA	Symptoms with hospitalization not indicated	Symptoms with hospitalization indicated	Life-threatening consequences (e.g., circulatory failure, hemorrhage, sepsis)
<b>Perforation (colon or rectum)</b>	NA	NA	Intervention indicated	Life-threatening consequences
<b>Proctitis</b>	Rectal discomfort with no intervention indicated	Symptoms causing greater than minimal interference with usual social & functional activities <u>OR</u> Medical intervention indicated	Symptoms causing inability to perform usual social & functional activities <u>OR</u> Operative intervention indicated	Life-threatening consequences (e.g., perforation)
<b>Rectal Discharge</b>	Visible discharge	Discharge requiring the use of pads	NA	NA
<b>Vomiting</b>	Transient or intermittent <u>AND</u> No or minimal interference with oral intake	Frequent episodes with no or mild dehydration	Persistent vomiting resulting in orthostatic hypotension <u>OR</u> Aggressive rehydration indicated (e.g., IV fluids)	Life-threatening consequences (e.g., hypotensive shock)

## Musculoskeletal

PARAMETER	GRADE 1 MILD	GRADE 2 MODERATE	GRADE 3 SEVERE	GRADE 4 POTENTIALLY LIFE- THREATENING
<b>Arthralgia</b>	Joint pain causing no or minimal interference with usual social & functional activities	Joint pain causing greater than minimal interference with usual social & functional activities	Joint pain causing inability to perform usual social & functional activities	Disabling joint pain causing inability to perform basic self-care functions
<b>Arthritis</b>	Stiffness or joint swelling causing no or minimal interference with usual social & functional activities	Stiffness or joint swelling causing greater than minimal interference with usual social & functional activities	Stiffness or joint swelling causing inability to perform usual social & functional activities	Disabling joint stiffness or swelling causing inability to perform basic self-care functions
<b>Myalgia (generalized)</b>	Muscle pain causing no or minimal interference with usual social & functional activities	Muscle pain causing greater than minimal interference with usual social & functional activities	Muscle pain causing inability to perform usual social & functional activities	Disabling muscle pain causing inability to perform basic self-care functions
<b>Osteonecrosis</b>	NA	No symptoms but with radiographic findings <u>AND</u> No operative intervention indicated	Bone pain with radiographic findings <u>OR</u> Operative intervention indicated	Disabling bone pain with radiographic findings causing inability to perform basic self-care functions
<b>Osteopenia<sup>6</sup></b> ≥ 30 years of age	BMD t-score -2.5 to -1	NA	NA	NA
< 30 years of age	BMD z-score -2 to -1	NA	NA	NA
<b>Osteoporosis<sup>6</sup></b> ≥ 30 years of age	NA	BMD t-score < -2.5	Pathologic fracture (e.g., compression fracture causing loss of vertebral height)	Pathologic fracture causing life-threatening consequences
< 30 years of age	NA	BMD z-score < -2	Pathologic fracture (e.g., compression fracture causing loss of vertebral height)	Pathologic fracture causing life-threatening consequences

<sup>6</sup> BMD t and z scores can be found in: Kanis JA on behalf of the World Health Organization Scientific Group (2007). Assessment of osteoporosis at the primary health-care level. Technical Report. World Health Organization Collaborating Centre for Metabolic Bone Diseases, University of Sheffield, UK. 2007: Printed by the University of Sheffield.

## Neurologic

PARAMETER	GRADE 1 MILD	GRADE 2 MODERATE	GRADE 3 SEVERE	GRADE 4 POTENTIALLY LIFE- THREATENING
Acute CNS Ischemia	NA	NA	Transient ischemic attack	Cerebral vascular accident (e.g., stroke with neurological deficit)
Altered Mental Status (for Dementia, see <i>Cognitive, Behavioral, or Attentional Disturbance</i> below)	Changes causing no or minimal interference with usual social & functional activities	Mild lethargy or somnolence causing greater than minimal interference with usual social & functional activities	Confusion, memory impairment, lethargy, or somnolence causing inability to perform usual social & functional activities	Delirium <u>OR</u> Obtundation <u>OR</u> Coma
Ataxia	Symptoms causing no or minimal interference with usual social & functional activities <u>OR</u> No symptoms with ataxia detected on examination	Symptoms causing greater than minimal interference with usual social & functional activities	Symptoms causing inability to perform usual social & functional activities	Disabling symptoms causing inability to perform basic self-care functions
Cognitive, Behavioral, or Attentional Disturbance (includes dementia and attention deficit disorder) <i>Specify type, if applicable</i>	Disability causing no or minimal interference with usual social & functional activities <u>OR</u> Specialized resources not indicated	Disability causing greater than minimal interference with usual social & functional activities <u>OR</u> Specialized resources on part-time basis indicated	Disability causing inability to perform usual social & functional activities <u>OR</u> Specialized resources on a full-time basis indicated	Disability causing inability to perform basic self-care functions <u>OR</u> Institutionalization indicated
Developmental Delay < 18 years of age  <i>Specify type, if applicable</i>	Mild developmental delay, either motor or cognitive, as determined by comparison with a developmental screening tool appropriate for the setting	Moderate developmental delay, either motor or cognitive, as determined by comparison with a developmental screening tool appropriate for the setting	Severe developmental delay, either motor or cognitive, as determined by comparison with a developmental screening tool appropriate for the setting	Developmental regression, either motor or cognitive, as determined by comparison with a developmental screening tool appropriate for the setting
Headache	Symptoms causing no or minimal interference with usual social & functional activities	Symptoms causing greater than minimal interference with usual social & functional activities	Symptoms causing inability to perform usual social & functional activities	Symptoms causing inability to perform basic self-care functions <u>OR</u> Hospitalization indicated <u>OR</u> Headache with significant impairment of alertness or other neurologic function

Neurologic

PARAMETER	GRADE 1 MILD	GRADE 2 MODERATE	GRADE 3 SEVERE	GRADE 4 POTENTIALLY LIFE- THREATENING
<b>Neuromuscular Weakness</b> (includes myopathy and neuropathy) <i>Specify type, if applicable</i>	Minimal muscle weakness causing no or minimal interference with usual social & functional activities <u>OR</u> No symptoms with decreased strength on examination	Muscle weakness causing greater than minimal interference with usual social & functional activities	Muscle weakness causing inability to perform usual social & functional activities	Disabling muscle weakness causing inability to perform basic self-care functions <u>OR</u> Respiratory muscle weakness impairing ventilation
<b>Neurosensory Alteration</b> (includes paresthesia and painful neuropathy) <i>Specify type, if applicable</i>	Minimal paresthesia causing no or minimal interference with usual social & functional activities <u>OR</u> No symptoms with sensory alteration on examination	Sensory alteration or paresthesia causing greater than minimal interference with usual social & functional activities	Sensory alteration or paresthesia causing inability to perform usual social & functional activities	Disabling sensory alteration or paresthesia causing inability to perform basic self-care functions
<b>Seizures</b> <i>New Onset Seizure</i> <i>≥ 18 years of age</i>	NA	NA	1 to 3 seizures	Prolonged and repetitive seizures (e.g., status epilepticus) <u>OR</u> Difficult to control (e.g., refractory epilepsy)
<i>&lt; 18 years of age</i> <i>(includes new or pre-existing febrile seizures)</i>	Seizure lasting < 5 minutes with < 24 hours postictal state	Seizure lasting 5 to < 20 minutes with < 24 hours postictal state	Seizure lasting ≥ 20 minutes <u>OR</u> > 24 hours postictal state	Prolonged and repetitive seizures (e.g., status epilepticus) <u>OR</u> Difficult to control (e.g., refractory epilepsy)
<i>Pre-existing Seizure</i>	NA	Increased frequency from previous level of control without change in seizure character	Change in seizure character either in duration or quality (e.g., severity or focality)	Prolonged and repetitive seizures (e.g., status epilepticus) <u>OR</u> Difficult to control (e.g., refractory epilepsy)
<b>Syncope</b>	Near syncope without loss of consciousness (e.g., pre-syncope)	Loss of consciousness with no intervention indicated	Loss of consciousness <u>AND</u> Hospitalization or intervention required	NA

## Pregnancy, Puerperium, and Perinatal

PARAMETER	GRADE 1 MILD	GRADE 2 MODERATE	GRADE 3 SEVERE	GRADE 4 POTENTIALLY LIFE- THREATENING
Stillbirth (report using mother's participant ID) <i>Report only one</i>	NA	NA	Fetal death occurring at $\geq 20$ weeks gestation	NA
Preterm Birth (report using mother's participant ID)	Live birth at 34 to < 37 weeks gestational age	Live birth at 28 to < 34 weeks gestational age	Live birth at 24 to < 28 weeks gestational age	Live birth at < 24 weeks gestational age
Spontaneous Abortion or Miscarriage <sup>7</sup> (report using mother's participant ID) <i>Report only one</i>	Chemical pregnancy	Uncomplicated spontaneous abortion or miscarriage	Complicated spontaneous abortion or miscarriage	NA

<sup>7</sup> Definition: A pregnancy loss occurring at < 20 weeks gestational age.

## Psychiatric

PARAMETER	GRADE 1 MILD	GRADE 2 MODERATE	GRADE 3 SEVERE	GRADE 4 POTENTIALLY LIFE- THREATENING
Insomnia	Mild difficulty falling asleep, staying asleep, or waking up early causing no or minimal interference with usual social & functional activities	Moderate difficulty falling asleep, staying asleep, or waking up early causing more than minimal interference with usual social & functional activities	Severe difficulty falling asleep, staying asleep, or waking up early causing inability to perform usual social & functional activities requiring intervention or hospitalization	NA
Psychiatric Disorders (includes anxiety, depression, mania, and psychosis) <i>Specify disorder</i>	Symptoms with intervention not indicated <u>OR</u> Behavior causing no or minimal interference with usual social & functional activities	Symptoms with intervention indicated <u>OR</u> Behavior causing greater than minimal interference with usual social & functional activities	Symptoms with hospitalization indicated <u>OR</u> Behavior causing inability to perform usual social & functional activities	Threatens harm to self or others <u>OR</u> Acute psychosis <u>OR</u> Behavior causing inability to perform basic self-care functions
Suicidal Ideation or Attempt <i>Report only one</i>	Preoccupied with thoughts of death <u>AND</u> No wish to kill oneself	Preoccupied with thoughts of death <u>AND</u> Wish to kill oneself with no specific plan or intent	Thoughts of killing oneself with partial or complete plans but no attempt to do so <u>OR</u> Hospitalization indicated	Suicide attempted

## Respiratory

PARAMETER	GRADE 1 MILD	GRADE 2 MODERATE	GRADE 3 SEVERE	GRADE 4 POTENTIALLY LIFE- THREATENING
<b>Acute Bronchospasm</b>	Forced expiratory volume in 1 second or peak flow reduced to $\geq 70$ to $< 80\%$ <u>OR</u> Mild symptoms with intervention not indicated	Forced expiratory volume in 1 second or peak flow 50 to $< 70\%$ <u>OR</u> Symptoms with intervention indicated <u>OR</u> Symptoms causing greater than minimal interference with usual social & functional activities	Forced expiratory volume in 1 second or peak flow 25 to $< 50\%$ <u>OR</u> Symptoms causing inability to perform usual social & functional activities	Forced expiratory volume in 1 second or peak flow $< 25\%$ <u>OR</u> Life-threatening respiratory or hemodynamic compromise <u>OR</u> Intubation
<b>Dyspnea or Respiratory Distress</b> <i>Report only one</i>	Dyspnea on exertion with no or minimal interference with usual social & functional activities <u>OR</u> Wheezing <u>OR</u> Minimal increase in respiratory rate for age	Dyspnea on exertion causing greater than minimal interference with usual social & functional activities <u>OR</u> Nasal flaring <u>OR</u> Intercostal retractions <u>OR</u> Pulse oximetry 90 to $< 95\%$	Dyspnea at rest causing inability to perform usual social & functional activities <u>OR</u> Pulse oximetry $< 90\%$	Respiratory failure with ventilator support indicated (e.g., CPAP, BPAP, intubation)



## Sensory

PARAMETER	GRADE 1 MILD	GRADE 2 MODERATE	GRADE 3 SEVERE	GRADE 4 POTENTIALLY LIFE- THREATENING
Hearing Loss <i>≥ 12 years of age</i>	NA	Hearing aid or intervention not indicated	Hearing aid or intervention indicated	Profound bilateral hearing loss (> 80 dB at 2 kHz and above) <u>OR</u> Non-serviceable hearing (i.e., >50 dB audiogram and <50% speech discrimination)
<i>&lt; 12 years of age (based on a 1, 2, 3, 4, 6 and 8 kHz audiogram)</i>	> 20 dB hearing loss at ≤ 4 kHz	> 20 dB hearing loss at > 4 kHz	> 20 dB hearing loss at ≥ 3 kHz in one ear with additional speech language related services indicated (where available) <u>OR</u> Hearing loss sufficient to indicate therapeutic intervention, including hearing aids	Audiologic indication for cochlear implant and additional speech-language related services indicated (where available)
Tinnitus	Symptoms causing no or minimal interference with usual social & functional activities with intervention not indicated	Symptoms causing greater than minimal interference with usual social & functional activities with intervention indicated	Symptoms causing inability to perform usual social & functional activities	NA
Uveitis	No symptoms <u>AND</u> Detectable on examination	Anterior uveitis with symptoms <u>OR</u> Medical intervention indicated	Posterior or pan-uveitis <u>OR</u> Operative intervention indicated	Disabling visual loss in affected eye(s)
Vertigo	Vertigo causing no or minimal interference with usual social & functional activities	Vertigo causing greater than minimal interference with usual social & functional activities	Vertigo causing inability to perform usual social & functional activities	Disabling vertigo causing inability to perform basic self-care functions
Visual Changes (assessed from baseline)	Visual changes causing no or minimal interference with usual social & functional activities	Visual changes causing greater than minimal interference with usual social & functional activities	Visual changes causing inability to perform usual social & functional activities	Disabling visual loss in affected eye(s)

## Systemic

PARAMETER	GRADE 1 MILD	GRADE 2 MODERATE	GRADE 3 SEVERE	GRADE 4 POTENTIALLY LIFE- THREATENING
<b>Acute Allergic Reaction</b>	Localized urticaria (wheals) with no medical intervention indicated	Localized urticaria with intervention indicated <u>OR</u> Mild angioedema with no intervention indicated	Generalized urticaria <u>OR</u> Angioedema with intervention indicated <u>OR</u> Symptoms of mild bronchospasm	Acute anaphylaxis <u>OR</u> Life-threatening bronchospasm <u>OR</u> Laryngeal edema
<b>Chills</b>	Symptoms causing no or minimal interference with usual social & functional activities	Symptoms causing greater than minimal interference with usual social & functional activities	Symptoms causing inability to perform usual social & functional activities	NA
<b>Cytokine Release Syndrome<sup>8</sup></b>	Mild signs and symptoms <u>AND</u> Therapy (i.e., antibody infusion) interruption not indicated	Therapy (i.e., antibody infusion) interruption indicated <u>AND</u> Responds promptly to symptomatic treatment <u>OR</u> Prophylactic medications indicated for ≤ 24 hours	Prolonged severe signs and symptoms <u>OR</u> Recurrence of symptoms following initial improvement	Life-threatening consequences (e.g., requiring pressor or ventilator support)
<b>Fatigue or Malaise</b> <i>Report only one</i>	Symptoms causing no or minimal interference with usual social & functional activities	Symptoms causing greater than minimal interference with usual social & functional activities	Symptoms causing inability to perform usual social & functional activities	Incapacitating symptoms of fatigue or malaise causing inability to perform basic self-care functions
<b>Fever (non-axillary temperatures only)</b>	38.0 to < 38.6°C or 100.4 to < 101.5°F	≥ 38.6 to < 39.3°C or ≥ 101.5 to < 102.7°F	≥ 39.3 to < 40.0°C or ≥ 102.7 to < 104.0°F	≥ 40.0°C or ≥ 104.0°F
<b>Pain<sup>9</sup></b> (not associated with study agent injections and not specified elsewhere) <i>Specify location</i>	Pain causing no or minimal interference with usual social & functional activities	Pain causing greater than minimal interference with usual social & functional activities	Pain causing inability to perform usual social & functional activities	Disabling pain causing inability to perform basic self-care functions <u>OR</u> Hospitalization indicated

<sup>8</sup> Definition: A disorder characterized by nausea, headache, tachycardia, hypotension, rash, and/or shortness of breath.

<sup>9</sup> For pain associated with injections or infusions, see the *Site Reactions to Injections and Infusions* section



## Systemic

PARAMETER	GRADE 1 MILD	GRADE 2 MODERATE	GRADE 3 SEVERE	GRADE 4 POTENTIALLY LIFE- THREATENING
Serum Sickness <sup>10</sup>	Mild signs and symptoms	Moderate signs and symptoms <u>AND</u> Intervention indicated (e.g., antihistamines)	Severe signs and symptoms <u>AND</u> Higher level intervention indicated (e.g., steroids or IV fluids)	Life-threatening consequences (e.g., requiring pressor or ventilator support)
Underweight <sup>11</sup> <i>&gt; 5 to 19 years of age</i>	WHO BMI z-score < -1 to -2	WHO BMI z-score < -2 to -3	WHO BMI z-score < -3	WHO BMI z-score < -3 with life-threatening consequences
<i>2 to 5 years of age</i>	WHO BMI z-score < -1 to -2	WHO Weight-for-height z-score < -2 to -3	WHO Weight-for-height z-score < -3	WHO Weight-for-height z-score < -3 with life-threatening consequences
<i>&lt; 2 years of age</i>	WHO BMI z-score < -1 to -2	WHO Weight-for-length z-score < -2 to -3	WHO Weight-for-length z-score < -3	WHO Weight-for-length z-score < -3 with life-threatening consequences
Unintentional Weight Loss (excludes postpartum weight loss)	NA	5 to < 9% loss in body weight from baseline	≥ 9 to < 20% loss in body weight from baseline	≥ 20% loss in body weight from baseline <u>OR</u> Aggressive intervention indicated (e.g., tube feeding, total parenteral nutrition)

<sup>10</sup> Definition: A disorder characterized by fever, arthralgia, myalgia, skin eruptions, lymphadenopathy, marked discomfort, and/or dyspnea.

<sup>11</sup> WHO reference tables may be accessed by clicking the desired age range or by accessing the following URLs:

[http://www.who.int/growthref/who2007\\_bmi\\_for\\_age/en/](http://www.who.int/growthref/who2007_bmi_for_age/en/) for participants > 5 to 19 years of age and

[http://www.who.int/childgrowth/standards/chart\\_catalogue/en/](http://www.who.int/childgrowth/standards/chart_catalogue/en/) for those ≤ 5 years of age.

## Urinary

PARAMETER	GRADE 1 MILD	GRADE 2 MODERATE	GRADE 3 SEVERE	GRADE 4 POTENTIALLY LIFE- THREATENING
Urinary Tract Obstruction	NA	Signs or symptoms of urinary tract obstruction without hydronephrosis or renal dysfunction	Signs or symptoms of urinary tract obstruction with hydronephrosis or renal dysfunction	Obstruction causing life-threatening consequences

## Site Reactions to Injections and Infusions

PARAMETER	GRADE 1 MILD	GRADE 2 MODERATE	GRADE 3 SEVERE	GRADE 4 POTENTIALLY LIFE- THREATENING
<b>Injection Site Pain or Tenderness</b> <i>Report only one</i>	Pain or tenderness causing no or minimal limitation of use of limb	Pain or tenderness causing greater than minimal limitation of use of limb	Pain or tenderness causing inability to perform usual social & functional activities	Pain or tenderness causing inability to perform basic self-care function OR Hospitalization indicated
<b>Injection Site Erythema or Redness<sup>12</sup></b> <i>Report only one</i> <i>&gt; 15 years of age</i>	2.5 to < 5 cm in diameter OR 6.25 to < 25 cm <sup>2</sup> surface area AND Symptoms causing no or minimal interference with usual social & functional activities	≥ 5 to < 10 cm in diameter OR ≥ 25 to < 100 cm <sup>2</sup> surface area OR Symptoms causing greater than minimal interference with usual social & functional activities	≥ 10 cm in diameter OR ≥ 100 cm <sup>2</sup> surface area OR Ulceration OR Secondary infection OR Phlebitis OR Sterile abscess OR Drainage OR Symptoms causing inability to perform usual social & functional activities	Potentially life-threatening consequences (e.g., abscess, exfoliative dermatitis, necrosis involving dermis or deeper tissue)
<i>≤ 15 years of age</i>	≤ 2.5 cm in diameter	> 2.5 cm in diameter with < 50% surface area of the extremity segment involved (e.g., upper arm or thigh)	≥ 50% surface area of the extremity segment involved (e.g., upper arm or thigh) OR Ulceration OR Secondary infection OR Phlebitis OR Sterile abscess OR Drainage	Potentially life-threatening consequences (e.g., abscess, exfoliative dermatitis, necrosis involving dermis or deeper tissue)
<b>Injection Site Induration or Swelling</b> <i>Report only one</i> <i>&gt; 15 years of age</i>	Same as for Injection Site Erythema or Redness, > 15 years of age	Same as for Injection Site Erythema or Redness, > 15 years of age	Same as for Injection Site Erythema or Redness, > 15 years of age	Same as for Injection Site Erythema or Redness, > 15 years of age
<i>≤ 15 years of age</i>	Same as for Injection Site Erythema or Redness, ≤ 15 years of age	Same as for Injection Site Erythema or Redness, ≤ 15 years of age	Same as for Injection Site Erythema or Redness, ≤ 15 years of age	Same as for Injection Site Erythema or Redness, ≤ 15 years of age
<b>Injection Site Pruritus</b>	Itching localized to the injection site that is relieved spontaneously or in < 48 hours of treatment	Itching beyond the injection site that is not generalized OR Itching localized to the injection site requiring ≥ 48 hours treatment	Generalized itching causing inability to perform usual social & functional activities	NA

<sup>12</sup> Injection Site Erythema or Redness should be evaluated and graded using the greatest single diameter or measured surface area.

## Laboratory Values\*

### Chemistries

PARAMETER	GRADE 1 MILD	GRADE 2 MODERATE	GRADE 3 SEVERE	GRADE 4 POTENTIALLY LIFE- THREATENING
Acidosis	NA	pH $\geq$ 7.3 to $<$ LLN	pH $<$ 7.3 without life-threatening consequences	pH $<$ 7.3 with life-threatening consequences
Albumin, Low (g/dL; g/L)	3.0 to $<$ LLN <i>30 to <math>&lt;</math> LLN</i>	$\geq$ 2.0 to $<$ 3.0 <i><math>\geq</math> 20 to <math>&lt;</math> 30</i>	$<$ 2.0 <i><math>&lt;</math> 20</i>	NA
Alkaline Phosphatase, High	1.25 to $<$ 2.5 x ULN	2.5 to $<$ 5.0 x ULN	5.0 to $<$ 10.0 x ULN	$\geq$ 10.0 x ULN
Alkalosis	NA	pH $>$ ULN to $\leq$ 7.5	pH $>$ 7.5 without life-threatening consequences	pH $>$ 7.5 with life-threatening consequences
ALT or SGPT, High <i>Report only one</i>	1.25 to $<$ 2.5 x ULN	2.5 to $<$ 5.0 x ULN	5.0 to $<$ 10.0 x ULN	$\geq$ 10.0 x ULN
Amylase (Pancreatic) or Amylase (Total), High <i>Report only one</i>	1.1 to $<$ 1.5 x ULN	1.5 to $<$ 3.0 x ULN	3.0 to $<$ 5.0 x ULN	$\geq$ 5.0 x ULN
AST or SGOT, High <i>Report only one</i>	1.25 to $<$ 2.5 x ULN	2.5 to $<$ 5.0 x ULN	5.0 to $<$ 10.0 x ULN	$\geq$ 10.0 x ULN
Bicarbonate, Low (mEq/L; mmol/L)	16.0 to $<$ LLN <i>16.0 to <math>&lt;</math> LLN</i>	11.0 to $<$ 16.0 <i>11.0 to <math>&lt;</math> 16.0</i>	8.0 to $<$ 11.0 <i>8.0 to <math>&lt;</math> 11.0</i>	$<$ 8.0 <i><math>&lt;</math> 8.0</i>
Bilirubin <i>Direct Bilirubin<sup>13</sup>, High &gt; 28 days of age</i>	NA	NA	$>$ ULN with other signs and symptoms of hepatotoxicity.	$>$ ULN with life-threatening consequences (e.g., signs and symptoms of liver failure)
<i><math>\leq</math> 28 days of age</i>	ULN to $\leq$ 1 mg/dL	$>$ 1 to $\leq$ 1.5 mg/dL	$>$ 1.5 to $\leq$ 2 mg/dL	$>$ 2 mg/dL
<i>Total Bilirubin, High &gt; 28 days of age</i>	1.1 to $<$ 1.6 x ULN	1.6 to $<$ 2.6 x ULN	2.6 to $<$ 5.0 x ULN with other signs and symptoms of hepatotoxicity.	$\geq$ 5.0 x ULN with life-threatening consequences (e.g., signs and symptoms of liver failure).
<i><math>\leq</math> 28 days of age</i>	See Appendix A. Total Bilirubin for Term and Preterm Neonates	See Appendix A. Total Bilirubin for Term and Preterm Neonates	See Appendix A. Total Bilirubin for Term and Preterm Neonates	See Appendix A. Total Bilirubin for Term and Preterm Neonates

\*Reminder: An asymptomatic abnormal laboratory finding without an accompanying AE should not be reported to DAIDS in an expedited time frame unless it meets protocol-specific reporting requirements.

<sup>13</sup> Direct bilirubin  $>$  1.5 mg/dL in a participant  $<$  28 days of age should be graded as grade 2, if  $<$  10% of the total bilirubin.

## Chemistries

PARAMETER	GRADE 1 MILD	GRADE 2 MODERATE	GRADE 3 SEVERE	GRADE 4 POTENTIALLY LIFE- THREATENING
<b>Calcium, High</b> (mg/dL; mmol/L) <i>≥ 7 days of age</i>	10.6 to < 11.5 2.65 to < 2.88	11.5 to < 12.5 2.88 to < 3.13	12.5 to < 13.5 3.13 to < 3.38	≥ 13.5 ≥ 3.38
<i>&lt; 7 days of age</i>	11.5 to < 12.4 2.88 to < 3.10	12.4 to < 12.9 3.10 to < 3.23	12.9 to < 13.5 3.23 to < 3.38	≥ 13.5 ≥ 3.38
<b>Calcium (Ionized), High</b> (mg/dL; mmol/L)	> ULN to < 6.0 > ULN to < 1.5	6.0 to < 6.4 1.5 to < 1.6	6.4 to < 7.2 1.6 to < 1.8	≥ 7.2 ≥ 1.8
<b>Calcium, Low</b> (mg/dL; mmol/L) <i>≥ 7 days of age</i>	7.8 to < 8.4 1.95 to < 2.10	7.0 to < 7.8 1.75 to < 1.95	6.1 to < 7.0 1.53 to < 1.75	< 6.1 < 1.53
<i>&lt; 7 days of age</i>	6.5 to < 7.5 1.63 to < 1.88	6.0 to < 6.5 1.50 to < 1.63	5.50 to < 6.0 1.38 to < 1.50	< 5.50 < 1.38
<b>Calcium (Ionized), Low</b> (mg/dL; mmol/L)	< LLN to 4.0 < LLN to 1.0	3.6 to < 4.0 0.9 to < 1.0	3.2 to < 3.6 0.8 to < 0.9	< 3.2 < 0.8
<b>Cardiac Troponin I, High</b>	NA	NA	NA	Levels consistent with myocardial infarction or unstable angina as defined by the local laboratory
<b>Creatine Kinase, High</b>	3 to < 6 x ULN	6 to < 10x ULN	10 to < 20 x ULN	≥ 20 x ULN
<b>Creatinine, High</b> <i>*Report only one</i>	1.1 to 1.3 x ULN	> 1.3 to 1.8 x ULN OR Increase to 1.3 to < 1.5 x participant's baseline	> 1.8 to < 3.5 x ULN OR Increase to 1.5 to < 2.0 x participant's baseline	≥ 3.5 x ULN OR Increase of ≥ 2.0 x participant's baseline
<b>Creatinine Clearance<sup>14</sup> or eGFR, Low</b> <i>*Report only one</i>	NA	< 90 to 60 ml/min or ml/min/1.73 m <sup>2</sup> OR 10 to < 30% decrease from participant's baseline	< 60 to 30 ml/min or ml/min/1.73 m <sup>2</sup> OR 30 to < 50% decrease from participant's baseline	< 30 ml/min or ml/min/1.73 m <sup>2</sup> OR ≥ 50% decrease from participant's baseline or dialysis needed
<b>Glucose</b> (mg/dL; mmol/L) <i>Fasting, High</i>	110 to 125 6.11 to < 6.95	> 125 to 250 6.95 to < 13.89	> 250 to 500 13.89 to < 27.75	≥ 500 ≥ 27.75
<i>Nonfasting, High</i>	116 to 160 6.44 to < 8.89	> 160 to 250 8.89 to < 13.89	> 250 to 500 13.89 to < 27.75	≥ 500 ≥ 27.75

<sup>14</sup> Use the applicable formula (i.e., Cockcroft-Gault in mL/min or Schwartz, MDRD, CKD-Epi in mL/min/1.73m<sup>2</sup>). Sites should choose the method defined in their study and when not specified, use the method most relevant to the study population.

\*Reminder: Choose the method that selects for the higher grade.

## Chemistries

PARAMETER	GRADE 1 MILD	GRADE 2 MODERATE	GRADE 3 SEVERE	GRADE 4 POTENTIALLY LIFE- THREATENING
<b>Glucose, Low</b> (mg/dL; mmol/L) ≥ 1 month of age	55 to 64 3.05 to <3.55	40 to <55 2.22 to < 3.05	30 to <40 1.67 to < 2.22	< 30 < 1.67
< 1 month of age	50 to 54 2.78 to < 3.00	40 to < 50 2.22 to < 2.78	30 to < 40 1.67 to < 2.22	< 30 < 1.67
<b>Lactate, High</b>	ULN to < 2.0 x ULN without acidosis	≥ 2.0 x ULN without acidosis	Increased lactate with pH < 7.3 without life- threatening consequences	Increased lactate with pH < 7.3 with life- threatening consequences
<b>Lipase, High</b>	1.1 to < 1.5 x ULN	1.5 to < 3.0 x ULN	3.0 to < 5.0 x ULN	≥ 5.0 x ULN
<b>Lipid Disorders</b> (mg/dL; mmol/L)				
<b>Cholesterol, Fasting, High</b> ≥ 18 years of age	200 to < 240 5.18 to < 6.19	240 to < 300 6.19 to < 7.77	≥ 300 ≥ 7.77	NA
< 18 years of age	170 to < 200 4.40 to < 5.15	200 to < 300 5.15 to < 7.77	≥ 300 ≥ 7.77	NA
<b>LDL, Fasting, High</b> ≥ 18 years of age	130 to < 160 3.37 to < 4.12	160 to < 190 4.12 to < 4.90	≥ 190 ≥ 4.90	NA
> 2 to < 18 years of age	110 to < 130 2.85 to < 3.34	130 to < 190 3.34 to < 4.90	≥ 190 ≥ 4.90	NA
<b>Triglycerides, Fasting, High</b>	150 to 300 1.71 to 3.42	>300 to 500 >3.42 to 5.7	>500 to <1,000 >5.7 to 11.4	> 1,000 > 11.4
<b>Magnesium<sup>15</sup>, Low</b> (mEq/L; mmol/L)	1.2 to < 1.4 0.60 to < 0.70	0.9 to < 1.2 0.45 to < 0.60	0.6 to < 0.9 0.30 to < 0.45	< 0.6 < 0.30
<b>Phosphate, Low</b> (mg/dL; mmol/L) > 14 years of age	2.0 to < LLN 0.65 to < LLN	1.4 to < 2.0 0.45 to < 0.65	1.0 to < 1.4 0.32 to < 0.45	< 1.0 < 0.32
1 to 14 years of age	3.0 to < 3.5 0.97 to < 1.13	2.5 to < 3.0 0.81 to < 0.97	1.5 to < 2.5 0.48 to < 0.81	< 1.5 < 0.48
< 1 year of age	3.5 to < 4.5 1.13 to < 1.45	2.5 to < 3.5 0.81 to < 1.13	1.5 to < 2.5 0.48 to < 0.81	< 1.5 < 0.48
<b>Potassium, High</b> (mEq/L; mmol/L)	5.6 to < 6.0 5.6 to < 6.0	6.0 to < 6.5 6.0 to < 6.5	6.5 to < 7.0 6.5 to < 7.0	≥ 7.0 ≥ 7.0
<b>Potassium, Low</b> (mEq/L; mmol/L)	3.0 to < 3.4 3.0 to < 3.4	2.5 to < 3.0 2.5 to < 3.0	2.0 to < 2.5 2.0 to < 2.5	< 2.0 < 2.0

<sup>15</sup> To convert a magnesium value from mg/dL to mmol/L, laboratories should multiply by 0.4114.

## Chemistries

PARAMETER	GRADE 1 MILD	GRADE 2 MODERATE	GRADE 3 SEVERE	GRADE 4 POTENTIALLY LIFE- THREATENING
<b>Sodium, High</b> (mEq/L; mmol/L)	146 to < 150 <i>146 to &lt; 150</i>	150 to < 154 <i>150 to &lt; 154</i>	154 to < 160 <i>154 to &lt; 160</i>	≥ 160 ≥ 160
<b>Sodium, Low</b> (mEq/L; mmol/L)	130 to < 135 <i>130 to &lt; 135</i>	125 to < 130 <i>125 to &lt; 130</i>	121 to < 125 <i>121 to &lt; 125</i>	≤ 120 ≤ 120
<b>Uric Acid, High</b> (mg/dL; mmol/L)	7.5 to < 10.0 <i>0.45 to &lt; 0.59</i>	10.0 to < 12.0 <i>0.59 to &lt; 0.71</i>	12.0 to < 15.0 <i>0.71 to &lt; 0.89</i>	≥ 15.0 ≥ 0.89

## Hematology

PARAMETER	GRADE 1 MILD	GRADE 2 MODERATE	GRADE 3 SEVERE	GRADE 4 POTENTIALLY LIFE- THREATENING
<b>Absolute CD4+ Count, Low</b> (cell/mm <sup>3</sup> ; cells/L) <i>&gt; 5 years of age</i> (not HIV infected)	300 to < 400 <i>300 to &lt; 400</i>	200 to < 300 <i>200 to &lt; 300</i>	100 to < 200 <i>100 to &lt; 200</i>	< 100 <i>&lt; 100</i>
<b>Absolute Lymphocyte Count, Low</b> (cell/mm <sup>3</sup> ; cells/L) <i>&gt; 5 years of age</i> (not HIV infected)	600 to < 650 <i>0.600 x 10<sup>9</sup> to &lt; 0.650 x 10<sup>9</sup></i>	500 to < 600 <i>0.500 x 10<sup>9</sup> to &lt; 0.600 x 10<sup>9</sup></i>	350 to < 500 <i>0.350 x 10<sup>9</sup> to &lt; 0.500 x 10<sup>9</sup></i>	< 350 <i>&lt; 0.350 x 10<sup>9</sup></i>
<b>Absolute Neutrophil Count (ANC), Low</b> (cells/mm <sup>3</sup> ; cells/L) <i>&gt; 7 days of age</i>	800 to 1,000 <i>0.800 x 10<sup>9</sup> to 1.000 x 10<sup>9</sup></i>	600 to 799 <i>0.600 x 10<sup>9</sup> to 0.799 x 10<sup>9</sup></i>	400 to 599 <i>0.400 x 10<sup>9</sup> to 0.599 x 10<sup>9</sup></i>	< 400 <i>&lt; 0.400 x 10<sup>9</sup></i>
<i>2 to 7 days of age</i>	1,250 to 1,500 <i>1.250 x 10<sup>9</sup> to 1.500 x 10<sup>9</sup></i>	1,000 to 1,249 <i>1.000 x 10<sup>9</sup> to 1.249 x 10<sup>9</sup></i>	750 to 999 <i>0.750 x 10<sup>9</sup> to 0.999 x 10<sup>9</sup></i>	< 750 <i>&lt; 0.750 x 10<sup>9</sup></i>
<i>≤ 1 day of age</i>	4,000 to 5,000 <i>4.000 x 10<sup>9</sup> to 5.000 x 10<sup>9</sup></i>	3,000 to 3,999 <i>3.000 x 10<sup>9</sup> to 3.999 x 10<sup>9</sup></i>	1,500 to 2,999 <i>1.500 x 10<sup>9</sup> to 2.999 x 10<sup>9</sup></i>	< 1,500 <i>&lt; 1.500 x 10<sup>9</sup></i>
<b>Fibrinogen, Decreased</b> (mg/dL; g/L)	100 to < 200 <i>1.00 to &lt; 2.00</i> <u>OR</u> 0.75 to < 1.00 x LLN	75 to < 100 <i>0.75 to &lt; 1.00</i> <u>OR</u> ≥ 0.50 to < 0.75 x LLN	50 to < 75 <i>0.50 to &lt; 0.75</i> <u>OR</u> 0.25 to < 0.50 x LLN	< 50 <i>&lt; 0.50</i> <u>OR</u> < 0.25 x LLN <u>OR</u> Associated with gross bleeding
<b>Hemoglobin<sup>16</sup>, Low</b> (g/dL; mmol/L) <sup>17</sup> <i>≥ 13 years of age</i> (male only)	10.0 to 10.9 <i>6.19 to 6.76</i>	9.0 to < 10.0 <i>5.57 to &lt; 6.19</i>	7.0 to < 9.0 <i>4.34 to &lt; 5.57</i>	< 7.0 <i>&lt; 4.34</i>
<i>≥ 13 years of age</i> (female only)	9.5 to 10.4 <i>5.88 to 6.48</i>	8.5 to < 9.5 <i>5.25 to &lt; 5.88</i>	6.5 to < 8.5 <i>4.03 to &lt; 5.25</i>	< 6.5 <i>&lt; 4.03</i>

<sup>16</sup> Male and female sex are defined as sex at birth. For transgender participants ≥13 years of age who have been on hormone therapy for more than 6 consecutive months, grade hemoglobin based on the gender with which they identify (i.e., a transgender female should be graded using the female sex at birth hemoglobin laboratory values).

<sup>17</sup> The most commonly used conversion factor to convert g/dL to mmol/L is 0.6206. For grading hemoglobin results obtained by an analytic method with a conversion factor other than 0.6206, the result must be converted to g/dL using appropriate conversion factor for the particular laboratory.



## Hematology

PARAMETER	GRADE 1 MILD	GRADE 2 MODERATE	GRADE 3 SEVERE	GRADE 4 POTENTIALLY LIFE- THREATENING
<i>57 days of age to &lt; 13 years of age (male and female)</i>	9.5 to 10.4 5.88 to 6.48	8.5 to < 9.5 5.25 to < 5.88	6.5 to < 8.5 4.03 to < 5.25	< 6.5 < 4.03
<i>36 to 56 days of age (male and female)</i>	8.5 to 9.6 5.26 to 5.99	7.0 to < 8.5 4.32 to < 5.26	6.0 to < 7.0 3.72 to < 4.32	< 6.0 < 3.72
<i>22 to 35 days of age (male and female)</i>	9.5 to 11.0 5.88 to 6.86	8.0 to < 9.5 4.94 to < 5.88	6.7 to < 8.0 4.15 to < 4.94	< 6.7 < 4.15
<i>8 to ≤ 21 days of age (male and female)</i>	11.0 to 13.0 6.81 to 8.10	9.0 to < 11.0 5.57 to < 6.81	8.0 to < 9.0 4.96 to < 5.57	< 8.0 < 4.96
<i>≤ 7 days of age (male and female)</i>	13.0 to 14.0 8.05 to 8.72	10.0 to < 13.0 6.19 to < 8.05	9.0 to < 10.0 5.59 to < 6.19	< 9.0 < 5.59
<b>INR, High</b> (not on anticoagulation therapy)	1.1 to < 1.5 x ULN	1.5 to < 2.0 x ULN	2.0 to < 3.0 x ULN	≥ 3.0 x ULN
<b>Methemoglobin</b> (% hemoglobin)	5.0 to < 10.0%	10.0 to < 15.0%	15.0 to < 20.0%	≥ 20.0%
<b>PTT, High</b> (not on anticoagulation therapy)	1.1 to < 1.66 x ULN	1.66 to < 2.33 x ULN	2.33 to < 3.00 x ULN	≥ 3.00 x ULN
<b>Platelets, Decreased</b> (cells/mm <sup>3</sup> ; cells/L)	100,000 to < 125,000 <i>100.000 x 10<sup>9</sup> to &lt; 125.000 x 10<sup>9</sup></i>	50,000 to < 100,000 <i>50.000 x 10<sup>9</sup> to &lt; 100.000 x 10<sup>9</sup></i>	25,000 to < 50,000 <i>25.000 x 10<sup>9</sup> to &lt; 50.000 x 10<sup>9</sup></i>	< 25,000 < 25.000 x 10 <sup>9</sup>
<b>PT, High</b> (not on anticoagulation therapy)	1.1 to < 1.25 x ULN	1.25 to < 1.50 x ULN	1.50 to < 3.00 x ULN	≥ 3.00 x ULN
<b>WBC, Decreased</b> (cells/mm <sup>3</sup> ; cells/L)				
<i>&gt; 7 days of age</i>	2,000 to 2,499 <i>2.000 x 10<sup>9</sup> to 2.499 x 10<sup>9</sup></i>	1,500 to 1,999 <i>1.500 x 10<sup>9</sup> to 1.999 x 10<sup>9</sup></i>	1,000 to 1,499 <i>1.000 x 10<sup>9</sup> to 1.499 x 10<sup>9</sup></i>	< 1,000 < 1.000 x 10 <sup>9</sup>
<i>≤ 7 days of age</i>	5,500 to 6,999 <i>5.500 x 10<sup>9</sup> to 6.999 x 10<sup>9</sup></i>	4,000 to 5,499 <i>4.000 x 10<sup>9</sup> to 5.499 x 10<sup>9</sup></i>	2,500 to 3,999 <i>2.500 x 10<sup>9</sup> to 3.999 x 10<sup>9</sup></i>	< 2,500 < 2.500 x 10 <sup>9</sup>



## Urinalysis

PARAMETER	GRADE 1 MILD	GRADE 2 MODERATE	GRADE 3 SEVERE	GRADE 4 POTENTIALLY LIFE- THREATENING
Glycosuria (random collection tested by dipstick)	Trace to 1+ or ≤ 250 mg	2+ or > 250 to ≤ 500 mg	> 2+ or > 500 mg	NA
Hematuria (not to be reported based on dipstick findings or on blood believed to be of menstrual origin)	6 to < 10 RBCs per high power field	≥ 10 RBCs per high power field	Gross, with or without clots <u>OR</u> With RBC casts <u>OR</u> Intervention indicated	Life-threatening consequences
Proteinuria (random collection tested by dipstick)	1+	2+	3+ or higher	NA

### Reference

U.S. Department of Health and Human Services, National Institutes of Health, National Institute of Allergy and Infectious Diseases, Division of AIDS. Division of AIDS (DAIDS) Table for Grading the Severity of Adult and Pediatric Adverse Events, Version 2.1. [March 2017]. Available from:

<https://rsc.tech-res.com/docs/default-source/safety/daids-ae-grading-table-mar2017.pdf>

### 11.3. Appendix 3: Liver Safety – Required actions, Follow up Assessments and Study Treatment Restart Guidelines

#### 11.3.1. VSLC Guidelines for Drug Restart after stop for Liver criteria

**Drug Restart** refers to resuming study treatment following liver events meeting stopping criteria **in which there is a clear underlying cause (other than DILI) of the liver event (e.g., biliary obstruction, pancreatic events, hypotension, acute viral hepatitis).**

Furthermore, there should be no evidence of alcoholic hepatitis or hypersensitivity, and the drug should not be associated with HLA markers of liver injury. (Table 12; Figure 17).

**Restarts should be limited to cases in which there is clear evidence that the underlying cause of the liver event is not related to study drug.**

#### DRUG RESTART

“Drug restart” can be approved by the VSLC for **transient, defined non-drug-induced** liver injury if no evidence of:

- immunoallergic injury /HLA association with injury
- alcoholic hepatitis

Study drug must be held while labs and evaluation are completed to assess diagnosis.

#### 11.3.2. VSLC Decision Process for Drug Restart Approval or Disapproval

- Principal Investigator (PI) requests consideration of drug re-initiation for a participant stable or improving on IP, who exhibits liver chemistry elevation meeting participant stopping criteria, which is transient, non-drug-related, and liver chemistries have improved to normal or are within 1.5x baseline and ALT < 5xULN.
- GSK Medical Monitor and GCSP Physician to review the participant’s diagnosis restart risk factors (Hepatotoxicity Panel consultation is available) and complete checklist (Table 12).
  - *must present source data defining the patient’s current resistance profile with documented evidence of extensive drug resistance and previous drug history.*
- The local operating company (LOC) medical director should be informed that study drug restart is under consideration and of the final decision, whether or not to proceed.
- Relevant physicians (listed below) must review and agree on action to be taken regarding request for drug restart:

- Safety Review Team Leader, Safety Development Leader, or Senior Safety Physician
- MDL and PPL Request is taken to VSLC for final decision

**Table 12 Checklist for Phase III drug restart after well-explained liver injury (e.g. biliary, pancreatic, hypotensive events, congestive heart failure (CHF), acute viral hepatitis), and improvement of liver chemistry to normal or  $\leq 1.5x$  baseline & ALT  $< 5x$  ULN**

	Yes	No
Is participant stable or improving on IP?		
<b>Do not restart</b> if the following risk factors at initial liver injury:		
fever, rash, eosinophilia, or hypersensitivity		
drug-induced liver injury		
alcoholic hepatitis (AST > ALT, typically $< 10x$ ULN)		
IP has an HLA genetic marker associated with liver injury (e.g. lapatinib, abacavir, amoxicillin/clavulanate)		
Source data defining the patients current resistance profile		
Previous drug history		

**Figure 17 VSLC process for drug restart approval or disapproval**

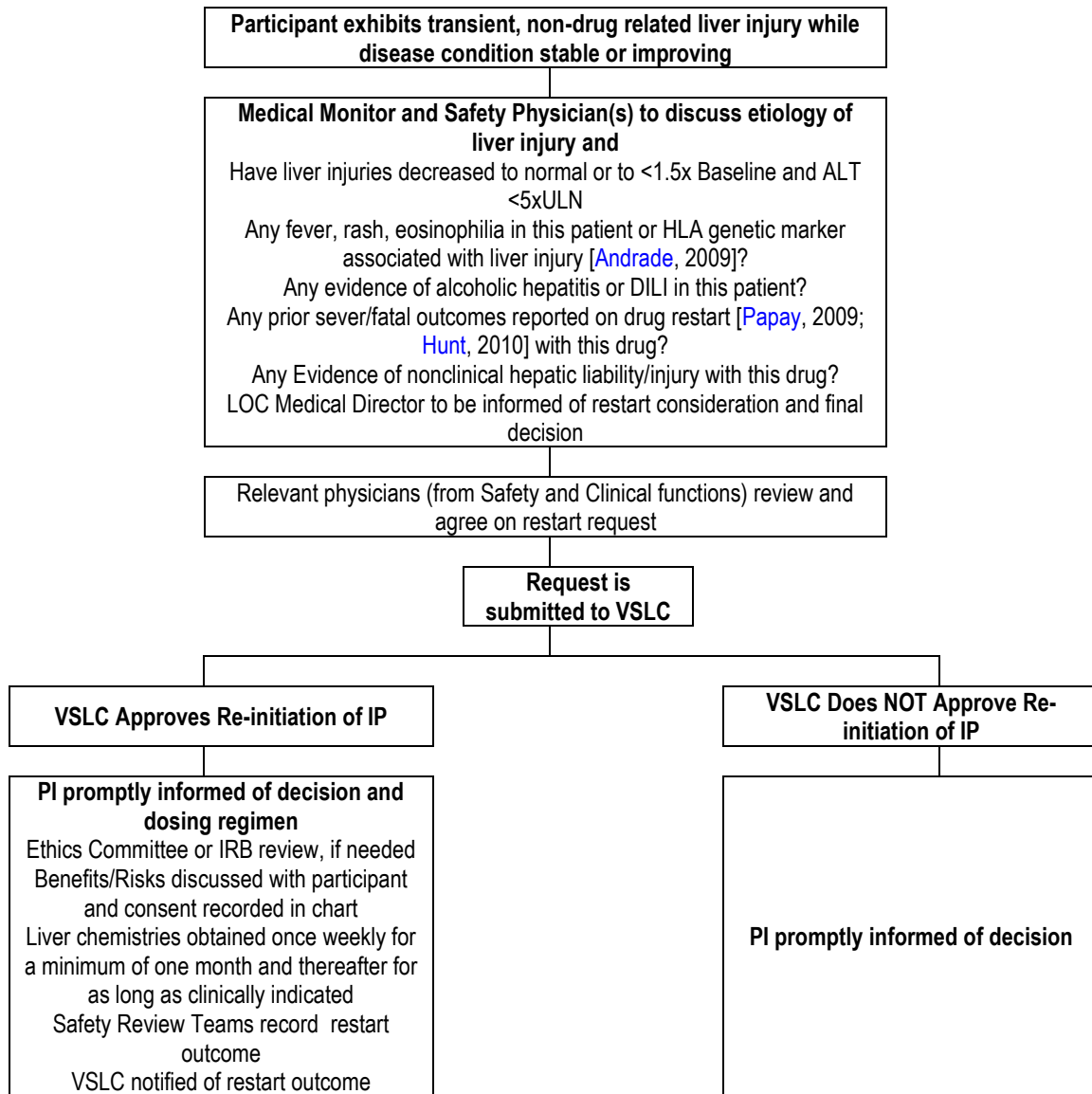

**11.3.3. Medical monitor, GCSP Physician and PI actions for Restart following VSLC decision**

**11.3.3.1. Medical Monitor and GCSP Physician Actions**

- Medical Monitor must notify PI of VSLC’s restart decision and recommended dosing regimen in writing and Medical Monitor must record note in study files.
- The Safety Review Team must record restart outcomes and the GCSP Physician must send these to the VSLC (see template below).
- All severe reactions (SAEs or fatalities which occur following a drug restart must be immediately reported to Line Management including, VSLC Chair, VP Global Medical Strategy and EU Qualified Person for Pharmacovigilance.

**11.3.3.2. PI Actions:**

- The PI must obtain Ethics Committee or Institutional Review Board approval of drug restart, as required.
- If VSLC approves drug restart, the patient must sign a new informed consent containing a clear description of possible benefits and risks of drug administration including recurrent, more severe liver injury or possible death.
- ***Targeted drug drug restart consent form must be used.***
- The patient’s informed consent must be recorded in the study chart, and the drug administered at agreed dose, as communicated by Medical Monitor.
- Liver chemistries must be followed ***once weekly for ‘restart’ cases*** for a minimum of one month and thereafter for as long as clinically indicated following drug re-initiation. If participant exhibits protocol-defined liver chemistry elevations, IP should be discontinued as protocol specified.
- Medical Monitor and the Ethics Committee or Institutional Review Board must be informed of the patient’s outcome following drug rechallenge or restart.

**Drug Drug Restart Outcomes Table Template**

**To be completed/updated and provided to VSLC with each event recorded across studies and indications**

**Drug Restart Outcomes Table – Update with each event**

Protocol#	Participant#	Safety outcome*	Drug benefit

**Restart safety outcomes:**

- 0 = no liver chemistry elevation
- 1 = recurrent liver chemistry elevation not meeting participant stopping criteria
- 2 = recurrent liver chemistry elevation meeting participant stopping criteria
- 3 = serious adverse event
- 4 = fatality

## 11.4. Appendix 4: CDC Classification for HIV-1 Infection (2014)

Note that the CD4+ T-lymphocyte count takes precedence over the CD4+ T-lymphocyte percentage in HIV infection stages 1, 2, and 3. The CD4+ T-lymphocyte should only be considered if the count is missing.

### HIV infection, stage 0

Indicates early HIV infection, inferred from a negative or indeterminate HIV test result within 180 days of a positive result. The criteria for stage 0 supersede and are independent of criteria used for other stages.

### HIV infection, stage 1

- Laboratory confirmation of HIV infection with no AIDS-defining condition, and
  - CD4+ T-lymphocyte count of  $\geq 500$  cells/ $\mu$ L, or
  - CD4+ T-lymphocyte percentage of total lymphocytes of  $\geq 26\%$ .

### HIV infection, stage 2

- Laboratory confirmation of HIV infection with no AIDS-defining condition, and
  - CD4+ T-lymphocyte count of 200 to 499 cells/ $\mu$ L, or
  - CD4+ T-lymphocyte percentage of total lymphocytes of 14% to 25%.

### HIV infection, stage 3 (AIDS)

- Laboratory confirmation of HIV infection, and
  - CD4+ T-lymphocyte count of  $< 200$  cells/ $\mu$ L, or
  - CD4+ T-lymphocyte percentage of total lymphocytes of  $< 14\%$ , or
  - Documentation of an AIDS-defining condition (see below).

Documentation of an AIDS-defining condition supersedes a CD4+ T-lymphocyte count of  $> 200$  cells/ $\mu$ L and a CD4+ T-lymphocyte percentage of total lymphocytes of  $> 14\%$ .

### HIV infection, stage unknown

- Laboratory confirmation of HIV infection, and
  - No information on CD4+ T-lymphocyte count or percentage, and
  - No information on presence of AIDS-defining conditions.

### Stage-3-defining opportunistic illnesses in HIV infection

- Candidiasis of bronchi, trachea, or lungs
- Candidiasis of oesophagus
- Cervical cancer, invasive

- Coccidioidomycosis, disseminated or extrapulmonary
- Cryptococcosis, extrapulmonary
- Cryptosporidiosis, chronic intestinal (>1 month's duration)
- Cytomegalovirus disease (other than liver, spleen, or nodes), onset at age >1 month
- Cytomegalovirus retinitis (with loss of vision)
- Encephalopathy, HIV-related
- Herpes simplex: chronic ulcers (>1 month's duration) or bronchitis, pneumonitis, or oesophagitis (onset at age >1 month)
- Histoplasmosis, disseminated or extrapulmonary
- Isosporiasis, chronic intestinal (>1 month's duration)
- Kaposi's sarcoma
- Lymphoma, Burkitt's (or equivalent term)
- Lymphoma, immunoblastic (or equivalent term)
- Lymphoma, primary, of brain
- Mycobacterium avium complex or Mycobacterium kansasii, disseminated or extrapulmonary
- Mycobacterium tuberculosis of any site, pulmonary, disseminated or extrapulmonary
- Mycobacterium, other species or unidentified species, disseminated or extrapulmonary
- Pneumocystis jirovecii pneumonia
- Pneumonia, recurrent
- Progressive multifocal leukoencephalopathy
- Salmonella septicaemia, recurrent
- Toxoplasmosis of brain, onset at age >1 month
- Wasting syndrome attributed to HIV.

## Reference

CDC. Revised Surveillance Case Definition for HIV Infection – United States, 2014. MMWR 2014; 63 (RR-03);1-10.

## 11.5. Appendix 5: Genetic Research

### Genetic Research Objectives and Analyses

The objectives of the genetic research are to investigate a relationship between genetic variants and:

- Response to medicine, including CAB + RPV or any concomitant medicines;
- HIV-1 susceptibility, severity and progression and related conditions.

Genetic data may be generated while the study is underway or following completion of the study. Genetic evaluations may include focused candidate gene approaches and/or examination of a large number of genetic variants throughout the genome (whole genome analyses). Genetic analyses will utilize data collected in the study and will be limited to understanding the objectives highlighted above. Analyses may be performed using data from multiple clinical studies to investigate these research objectives.

Appropriate descriptive and/or statistical analysis methods will be used. A detailed description of any planned analyses will be documented in a RAP prior to initiation of the analysis. Planned analyses and results of genetic investigations will be reported either as part of the clinical RAP and study report, or in a separate genetics RAP and report, as appropriate.

### Study Population

Any participant who is enrolled in the clinical study can participate in genetic research. Any participant who has received an allogeneic bone marrow transplant must be excluded from genetic research.

### Study Assessments and Procedures

A key component of successful genetic research is the collection of samples during clinical studies. Collection of samples, even when no a priori hypothesis has been identified, may enable future genetic analyses to be conducted to help understand variability in disease and medicine response.

- A 6 mL blood sample will be taken for deoxyribonucleic acid (DNA) extraction. A blood sample is collected at the baseline visit, after the participant has been randomized and provided informed consent for genetic research. Instructions for collection and shipping of the genetic sample are described in the laboratory manual. The DNA from the blood sample may undergo quality control analyses to confirm the integrity of the sample. If there are concerns regarding the quality of the sample, then the sample may be destroyed. The blood sample is taken on a single occasion unless a duplicate sample is required due to an inability to utilize the original sample.

The genetic sample is labelled (or “coded”) with the same study specific number used to label other samples and data in the study. This number can be traced or linked back to



the participant by the investigator or site staff. Coded samples do not carry personal identifiers (such as name or social security number).

Samples will be stored securely and may be kept for up to 15 years after the last participant completes the study, or GSK may destroy the samples sooner. GSK or those working with GSK (for example, other researchers) will only use samples collected from the study for the purpose stated in this protocol and in the informed consent form. Samples may be used as part of the development of a companion diagnostic to support the GSK medicinal product.

Participants can request their sample to be destroyed at any time.

### **Informed Consent**

Participants who do not wish to participate in the genetic research may still participate in the study. Genetic informed consent must be obtained prior to any blood being taken.

### **Participant Withdrawal from Study**

If a participant who has consented to participate in genetic research withdraws from the clinical study for any reason other than being lost to follow-up, the participant will be given a choice of one of the following options concerning the genetic sample, if already collected:

- Continue to participate in the genetic research in which case the genetic DNA sample is retained
- Discontinue participation in the genetic research and destroy the genetic DNA sample.

In the event a participant withdraws from the study and requests destruction of their samples then the site staff must document this in the site study records, complete form F-GRD-001 and must inform ViiV/GSK via the CRA within 5 days of notification by the participant to trigger sample destruction requests.

Genotype data may be generated during the study or after completion of the study and may be analyzed during the study or stored for future analysis.

- If a participant withdraws consent for genetic research and genotype data has not been analyzed, it will not be analyzed or used for future research.
- Genetic data that has been analyzed at the time of withdrawn consent will continue to be stored and used, as appropriate.

**Screen and Baseline Failures**

If a sample for genetic research has been collected and it is determined that the participant does not meet the entry criteria for participation in the study, then the investigator should instruct the participant that their genetic sample will be destroyed. No forms are required to complete this process as it will be completed as part of the consent and sample reconciliation process. In this instance a sample destruction form will not be available to include in the site files.

**Provision of Study Results and Confidentiality of Participant's Genetic Data**

ViiV/GSK may summarize the genetic research results in the CSR, or separately, and may publish the results in scientific journals.

ViiV/GSK may share genetic research data with other scientists to further scientific understanding in alignment with the informed consent. GSK does not inform the participant, family members, insurers, or employers of individual genotyping results that are not known to be relevant to the participant's medical care at the time of the study, unless required by law. This is due to the fact that the information generated from genetic studies is generally preliminary in nature, and therefore the significance and scientific validity of the results are undetermined. Further, data generated in a research laboratory may not meet regulatory requirements for inclusion in clinical care.

## 11.6. Appendix 6: Definition of and Procedures for Recording, Evaluating, Follow-Up and Reporting of Adverse Events

### 11.6.1. Definition of Adverse Events

#### Adverse Event Definition:

- An AE is any untoward medical occurrence in a patient or clinical investigation participant, temporally associated with the use of a medicinal product, whether or not considered related to the medicinal product.
- NOTE: An AE can therefore be any unfavorable and unintended sign (including an abnormal laboratory finding), symptom, or disease (new or exacerbated) temporally associated with the use of a medicinal product.

#### Events meeting AE definition include:

- Any abnormal laboratory test results (hematology, clinical chemistry, or urinalysis) or other safety assessments (e.g., ECGs, radiological scans, vital signs measurements), including those that worsen from baseline, and felt to be clinically significant in the medical and scientific judgement of the investigator.
- Exacerbation of a chronic or intermittent pre-existing condition including either an increase in frequency and/or intensity of the condition.
- New conditions detected or diagnosed after study treatment administration even though it may have been present prior to the start of the study.
- Signs, symptoms, or the clinical sequelae of a suspected interaction.
- Signs, symptoms, or the clinical sequelae of a suspected overdose of either study treatment or a concomitant medication (overdose per se will not be reported as an AE/SAE unless this is an intentional overdose taken with possible suicidal/self-harming intent. This should be reported regardless of sequelae).
- "Lack of efficacy" or "failure of expected pharmacological action" per se will not be reported as an AE or SAE. However, the signs and symptoms and/or clinical sequelae resulting from lack of efficacy will be reported if they fulfil the definition of an AE or SAE.

**Events NOT meeting definition of an AE include:**

- Any clinically significant abnormal laboratory findings or other abnormal safety assessments which are associated with the underlying disease, unless judged by the investigator to be more severe than expected for the participant's condition.
- The disease/disorder being studied or expected progression, signs, or symptoms of the disease/disorder being studied, unless more severe than expected for the participant's condition.
- Medical or surgical procedure (e.g., endoscopy, appendectomy): the condition that leads to the procedure is an AE.
- Situations where an untoward medical occurrence did not occur (social and/or convenience admission to a hospital).
- Anticipated day-to-day fluctuations of pre-existing disease(s) or condition(s) present or detected at the start of the study that do not worsen.

**11.6.2. Definition of Serious Adverse Events**

If an event is not an AE per definition above, then it cannot be an SAE even if serious conditions are met (e.g., hospitalization for signs/symptoms of the disease under study, death due to progression of disease, etc.).

**Serious Adverse Event (SAE) is defined as any untoward medical occurrence that, at any dose:**

**Results in death****Is life-threatening**

NOTE:

The term 'life-threatening' in the definition of 'serious' refers to an event in which the participant was at risk of death at the time of the event. It does not refer to an event, which hypothetically might have caused death, if it were more severe.

**Requires hospitalization or prolongation of existing hospitalization**

NOTE:

- In general, hospitalization signifies that the participant has been detained (usually involving at least an overnight stay) at the hospital or emergency ward for observation and/or treatment that would not have been appropriate in the physician's office or out-patient setting. Complications that occur during hospitalization are AEs. If a complication prolongs hospitalization or fulfills any other serious criteria, the event is serious. When in doubt as to whether "hospitalization" occurred or was necessary, the AE should be considered serious.
- Hospitalization for elective treatment of a pre-existing condition that did not worsen from baseline is not considered an AE.

**Results in disability/incapacity**

## NOTE:

- The term disability means a substantial disruption of a person's ability to conduct normal life functions.
- This definition is not intended to include experiences of relatively minor medical significance such as uncomplicated headache, nausea, vomiting, diarrhea, influenza, and accidental trauma (e.g. sprained ankle) which may interfere or prevent everyday life functions but do not constitute a substantial disruption

**Is a congenital anomaly/birth defect****Other situations:**

- Medical or scientific judgment should be exercised in deciding whether reporting is appropriate in other situations, such as important medical events that may not be immediately life-threatening or result in death or hospitalization but may jeopardize the participant or may require medical or surgical intervention to prevent one of the other outcomes listed in the above definition. These should also be considered serious.
- Examples of such events are invasive or malignant cancers, intensive treatment in an emergency room or at home for allergic bronchospasm, blood dyscrasias or convulsions that do not result in hospitalization, or development of drug dependency or drug abuse

**Is associated with liver injury and impaired liver function defined as:**

- $ALT \geq 3xULN$  and total bilirubin\*  $\geq 2xULN$  (>35% direct), **or**
- $ALT \geq 3xULN$  and  $INR^{**} > 1.5$ .

\* Serum bilirubin fractionation should be performed if testing is available; if unavailable, measure urinary bilirubin via dipstick. If fractionation is unavailable and  $ALT \geq 3xULN$  and total bilirubin  $\geq 2xULN$ , then the event is still to be reported as an SAE.

\*\* INR testing not required per protocol and the threshold value does not apply to participants receiving anticoagulants. If INR measurement is obtained, the value is to be recorded on the SAE form.

### 11.6.3. Definition of Cardiovascular Events

#### Cardiovascular Events (CV) Definition:

Investigators will be required to fill out the specific CV event page of the eCRF for the following AEs and SAEs:

- Myocardial infarction/unstable angina
- Congestive heart failure
- Arrhythmias
- Valvulopathy
- Pulmonary hypertension
- Cerebrovascular events/stroke and transient ischemic attack
- Peripheral arterial thromboembolism
- Deep venous thrombosis/pulmonary embolism
- Revascularization

### 11.6.4. Recording of AEs and SAEs

#### AEs and SAE Recording:

- When an AE/SAE occurs, it is the responsibility of the investigator to review all documentation (e.g., hospital progress notes, laboratory, and diagnostics reports) relative to the event.
- The investigator will then record all relevant information regarding an AE/SAE in the eCRF
- It is **not** acceptable for the investigator to send photocopies of the participant's medical records to GSK in lieu of completion of the GSK, AE/SAE CRF page.
- There may be instances when copies of medical records for certain cases are requested by GSK. In this instance, all participant identifiers, with the exception of the participant number, will be blinded on the copies of the medical records prior to submission to GSK.
- The investigator will attempt to establish a diagnosis of the event based on signs, symptoms, and/or other clinical information. In such cases, the diagnosis will be documented as the AE/SAE and not the individual signs/symptoms.
- Participant-completed Value Evidence and Outcomes questionnaires and the collection of AE data are independent components of the study.
- Responses to each question in the Value Evidence and Outcomes questionnaire will be treated in accordance with standard scoring and statistical procedures detailed by the scale's developer.
- The use of a single question from a multidimensional health survey to designate a cause-effect relationship to an AE is inappropriate.

### 11.6.5. Evaluating AEs and SAEs

#### Assessment of Intensity

The investigator will make an assessment of intensity for each AE, SAE and device deficiency reported during the study and will assign it to one of the following categories:

- Mild: An event that is easily tolerated by the participant, causing minimal discomfort and not interfering with everyday activities.
- Moderate: An event that is sufficiently discomforting to interfere with normal everyday activities
- Severe: An event that prevents normal everyday activities. - an AE that is assessed as severe will not be confused with an SAE. Severity is a category utilized for rating the intensity of an event; and both AEs and SAEs can be assessed as severe.
- An event is defined as 'serious' when it meets at least one of the pre-defined outcomes as described in the definition of an SAE.

#### Assessment of Causality

- The investigator is obligated to assess the relationship between study treatment and the occurrence of each AE/SAE/device deficiency.
- A "reasonable possibility" is meant to convey that there are facts/evidence or arguments to suggest a causal relationship, rather than a relationship cannot be ruled out.
- The investigator will use clinical judgment to determine the relationship.
- Alternative causes, such as natural history of the underlying diseases, concomitant therapy, other risk factors, and the temporal relationship of the event to the study treatment will be considered and investigated.
- The investigator will also consult the Investigator Brochure (IB) and/or Product Information, for marketed products, in the determination of his/her assessment.
- For each AE/SAE/device deficiency the investigator **must** document in the medical notes that he/she has reviewed the AE/SAE/device deficiency and has provided an assessment of causality.
- There may be situations when an SAE has occurred and the investigator has minimal information to include in the initial report to GSK. However, **it is very important that the investigator always make an assessment of causality for every event prior to the initial transmission of the SAE data to GSK.**
- The investigator may change his/her opinion of causality in light of follow-up information, amending the SAE data collection tool accordingly.
- The causality assessment is one of the criteria used when determining regulatory reporting requirements.

**Follow-up of AEs, SAEs and device deficiency**

- The investigator is obligated to perform or arrange for the conduct of supplemental measurements and/or evaluations as may be indicated or as requested by GSK to elucidate as fully as possible the nature and/or causality of the AE, SAE and device deficiency.
- The investigator is obligated to assist. This may include additional laboratory tests or investigations, histopathological examinations or consultation with other health care professionals.
- If a participant dies during participation in the study or during a recognized follow-up period, the investigator will provide GSK with a copy of any post-mortem findings, including histopathology.
- New or updated information will be recorded in the originally completed CRF.
- The investigator will submit any updated SAE data to GSK within the designated reporting time frames.

**11.6.6. Reporting of SAEs to GSK****SAE reporting to GSK via electronic data collection tool**

- Primary mechanism for reporting SAEs to GSK will be the electronic data collection tool
- If the electronic system is unavailable for greater than 24 hours, the site will use the paper SAE data collection tool and fax it to the Medical Monitor.
- Site will enter the serious adverse event data into the electronic system as soon as it becomes available.
- The investigator will be required to confirm review of the SAE causality by ticking the 'reviewed' box at the bottom of the eCRF page within 72 hours of submission of the SAE.
- After the study is completed at a given site, the electronic data collection tool (e.g., InForm system) will be taken off-line to prevent the entry of new data or changes to existing data
- If a site receives a report of a new SAE from a study participant or receives updated data on a previously reported SAE after the electronic data collection tool has been taken off-line, the site can report this information on a paper SAE form or to the Medical Monitor by telephone.
- Contacts for SAE receipt can be found in the Study Reference Manual.



**SAE reporting to GSK via paper CRF**

- Facsimile transmission of the SAE paper CRF is the preferred method to transmit this information to the Medical Monitor or the SAE coordinator
- In rare circumstances and in the absence of facsimile equipment, notification by telephone is acceptable, with a copy of the SAE data collection tool sent by overnight mail
- Initial notification via the telephone does not replace the need for the investigator to complete and sign the SAE CRF pages within the designated reporting time frames.
- Contacts for SAE receipt can be found in the Study Reference Manual.

## 11.7. Appendix 7: Contraceptive Guidance and Collection of Pregnancy Information

### Definitions

#### Woman of Childbearing Potential (WOCBP)

A woman is considered fertile following menarche and until becoming post-menopausal unless permanently sterile (see below)

#### Women in the following categories are not considered WOCBP

- a. Premenarchal
- b. Premenopausal female with ONE of the following:
  - Documented hysterectomy
  - Documented bilateral salpingectomy
  - Documented bilateral oophorectomy

Note: Documentation can come from the site personnel's: review of participant's medical records, medical examination, or medical history interview.

- c. Postmenopausal female
  - A postmenopausal state is defined as no menses for 12 months without an alternative medical cause. A high follicle stimulating hormone (FSH) level in the postmenopausal range may be used to confirm a postmenopausal state in women not using hormonal contraception or hormonal replacement therapy (HRT). However, in the absence of 12 months of amenorrhea, a single FSH measurement is insufficient.
  - Females on HRT and whose menopausal status is in doubt will be required to use one of the non-hormonal highly effective contraception methods if they wish to continue their HRT during the study. Otherwise, they must discontinue HRT to allow confirmation of postmenopausal status before study enrollment.

#### Contraception Guidance

Female participants of childbearing potential are eligible to participate if they agree to use a highly effective method of contraception consistently and correctly as described in [Table 13](#).

**Table 13 Highly Effective Contraceptive Methods**

<p><b>Highly Effective Contraceptive Methods That Are User Dependent <sup>a</sup></b>  <i>Failure rate of &lt;1% per year when used consistently and correctly.</i></p>
<p>Combined (estrogen and progestogen-containing ) hormonal contraception associated with inhibition of ovulation</p> <ul style="list-style-type: none"> <li>• oral</li> <li>• intravaginal</li> <li>• transdermal</li> </ul>
<p>Progestogen-only hormonal contraception associated with inhibition of ovulation</p> <ul style="list-style-type: none"> <li>• injectable</li> </ul>
<p><b>Highly Effective Methods That Are User Independent</b></p>
<ul style="list-style-type: none"> <li>• Implantable progestogen-only hormonal contraception associated with inhibition of ovulation</li> <li>• Intrauterine device (IUD)</li> <li>• Intrauterine hormone-releasing system (IUS)</li> <li>• bilateral tubal occlusion</li> </ul>
<p>Vasectomized partner</p> <p><i>(A vasectomized partner is a highly effective contraception method provided that the partner is the sole male sexual partner of the WOCBP and the absence of sperm has been confirmed. If not, an additional highly effective method of contraception should be used.)</i></p>
<p>Sexual abstinence</p> <p><i>(Sexual abstinence is considered a highly effective method only if defined as refraining from heterosexual intercourse during the entire period of risk associated with the study drug. The reliability of sexual abstinence needs to be evaluated in relation to the duration of the study and the preferred and usual lifestyle of the participant.)</i></p>
<p>a. Typical use failure rates may differ from those when used consistently and correctly. Use should be consistent with local regulations regarding the use of contraceptive methods for participants in clinical studies.</p>

**Pregnancy Testing**

- WOCBP should only be included after a confirmed menstrual period and a negative highly sensitive serum pregnancy test
- Additional pregnancy testing should be performed as per the study Time and Events Table.
- Pregnancy testing will be performed whenever a menstrual cycle is missed or when pregnancy is otherwise suspected
- Pregnancy testing will be performed and assayed in the central laboratory OR using the test kit provided by the central laboratory / provided by the sponsor

- /approved by the sponsor and in accordance with instructions provided in its package insert]
- If pregnancy is confirmed, please see [Appendix 11](#) for details regarding allowing pregnant participants to remain in the study

### 11.7.1. Collection of Pregnancy Information

- The Investigator will collect pregnancy information on **any** participant who becomes pregnant while participating in this study. See [Appendix 11](#) and [11.11.1](#) for information to be collected for participants who become pregnant while participating in this study.
- Participants who become pregnant while in the study may remain in study and continue scheduled dosing with CAB + RPV LA, once a pregnancy specific ICF addendum is signed by the participant. See [Appendix 11](#) for additional data and information regarding the management of participants who remain in the study while pregnant. Information will be recorded on the appropriate form and submitted to GSK within 24 hours of learning of a participant's pregnancy.
- Participant will be followed to determine the outcome of the pregnancy. The investigator will collect follow-up information on mother and infant, which will be forwarded to GSK. Generally, follow-up will not be required for longer than 6 to 8 weeks beyond the estimated delivery date.
- Any termination of pregnancy will be reported, regardless of fetal status (presence or absence of anomalies) or indication for procedure.
- While pregnancy itself is not considered to be an AE or SAE, any pregnancy complication or elective termination of a pregnancy for medical reasons will be reported as an AE or SAE.
- A spontaneous abortion is always considered to be an SAE and will be reported as such.
- Any SAE occurring as a result of a post-study pregnancy which is considered reasonably related to the study treatment by the investigator, will be reported to GSK as described in this section. While the investigator is not obligated to actively seek this information in former study participants, he or she may learn of an SAE through spontaneous reporting.

## **11.8. Appendix 8: Study governance Considerations**

### **11.8.1. Regulatory and Ethical Considerations, Including the Informed Consent Process**

Prior to initiation of a site, ViiV/GSK will obtain favorable opinion/approval from the appropriate regulatory agency to conduct the study in accordance with International Conference on Harmonisation (ICH) Good Clinical Practice (GCP) and applicable country-specific regulatory requirements.

The study will be conducted in accordance with all applicable regulatory requirements, and with GSK policy.

- This study will be conducted in accordance with the protocol and with:
  - Consensus ethical principles derived from international guidelines including the Declaration of Helsinki and Council for International Organizations of Medical Sciences (CIOMS) International Ethical Guidelines
  - Applicable ICH Good Clinical Practice (GCP) Guidelines
  - Applicable laws and regulations
- The protocol, protocol amendments, ICF, Investigator Brochure, and other relevant documents (e.g., advertisements) must be submitted to an IRB/IEC by the investigator and reviewed and approved by the IRB/IEC before the study is initiated.
- Any amendments to the protocol will require IEC/IRB approval before implementation of changes made to the study design, except for changes necessary to eliminate an immediate hazard to study participants.
- The investigator will be responsible for the following:
  - Providing written summaries of the status of the study to the IRB/IEC annually or more frequently in accordance with the requirements, policies, and procedures established by the IRB/EC
  - Notifying the IRB/IEC of SAE or other significant safety findings as required by IRB/IEC procedures
  - Providing oversight of the conduct of the study at the site and adherence to requirements of 21 CFR, ICH guidelines, the IRB/IEC, European regulation 536/2014 for clinical studies (if applicable), and all other applicable local regulations

### **11.8.2. Financial Disclosure**

Investigators and sub-investigators will provide the sponsor with sufficient, accurate financial information as requested to allow the sponsor to submit complete and accurate financial certification or disclosure statements to the appropriate regulatory authorities.

Investigators are responsible for providing information on financial interests during the course of the study and for 1 year after completion of the study.

### **11.8.3. Informed Consent Process**

- The investigator or his/her representative will explain the nature of the study to the participant or his/her legally authorized representative and answer all questions regarding the study.
- Participants must be informed that their participation is voluntary. Participants or their legally authorized representative will be required to sign a statement of informed consent that meets the requirements of 21 CFR 50, local regulations, ICH guidelines, Health Insurance Portability and Accountability Act (HIPAA) requirements, where applicable, and the IRB/IEC or study center.
- The medical record must include a statement that written informed consent was obtained before the participant was enrolled in the study and the date the written consent was obtained. The authorized person obtaining the informed consent must also sign the ICF.
- Participants must be re-consented to the most current version of the ICF(s) during their participation in the study.
- A copy of the ICF(s) must be provided to the participant or the participant's legally authorized representative.
- Participants who are rescreened are required to sign a new ICF.
- Participants who become pregnant while in the study and who elect to continue to receive CAB + RPV LA injections must sign the pregnancy specific ICF addendum.
- If an associated person experiences a medical device incident with an AE, the associated person will be provided with a safety reporting information and authorization letter.

The ICF may contain a separate section that addresses the use of remaining mandatory samples for optional exploratory research in accordance with SOP-GSKF-410. The investigator or authorized designee will explain to each participant the objectives of the exploratory research. Participants will be told that they are free to refuse to participate and may withdraw their consent at any time and for any reason during the storage period. A separate signature will be required to document a participant's agreement to allow any remaining specimens to be used for exploratory research. Participants who decline to participate will not provide this separate signature.

### **11.8.4. Data Protection**

- Participants will be assigned a unique identifier by the sponsor. Any participant records or datasets that are transferred to the sponsor will contain the identifier

only; participant names or any information which would make the participant identifiable will not be transferred.

- The participant must be informed that his/her personal study-related data will be used by the sponsor in accordance with local data protection law. The level of disclosure must also be explained to the participant.
- The participant must be informed that his/her medical records may be examined by Clinical Quality Assurance auditors or other authorized personnel appointed by the sponsor, by appropriate IRB/IEC members, and by inspectors from regulatory authorities.

#### **11.8.5. Independent Data Monitoring Committee**

An IDMC will be utilized in this study to ensure external objective medical and/or statistical review of safety and/or efficacy issues in order to protect the ethical and safety interests of participants and to protect the scientific validity of the study. The schedule of any planned interim analysis and the analysis plan for IDMC review is described in Section 9.2.3 and the IDMC the charter, which is available upon request..

#### **11.8.6. Quality Control (Study Monitoring)**

- In accordance with applicable regulations including GCP, and GSK procedures, GSK monitors will contact the site prior to the start of the study to review with the site staff the protocol, study requirements, and their responsibilities to satisfy regulatory, ethical, and GSK requirements.
- When reviewing data collection procedures, the discussion will also include identification, agreement and documentation of data items for which the eCRF will serve as the source document.

GSK will monitor the study and site activity to verify that the:

- Data are authentic, accurate, and complete.
- Safety and rights of participants are being protected.
- Study is conducted in accordance with the currently approved protocol and any other study agreements, GCP, and all applicable regulatory requirements.

The investigator and the head of the medical institution (where applicable) agrees to allow the monitor direct access to all relevant documents

#### **11.8.7. Data Quality Assurance**

- All participant data relating to the study will be recorded on printed or electronic CRF unless transmitted to the sponsor or designee electronically (e.g., laboratory data). The investigator is responsible for verifying that data entries are accurate and correct by physically or electronically signing the CRF.
- The investigator must maintain accurate documentation (source data) that supports the information entered in the CRF.

- The investigator must permit study-related monitoring, audits, IRB/IEC review, and regulatory agency inspections and provide direct access to source data documents.
- The sponsor or designee is responsible for the data management of this study including quality checking of the data. Detailed information about study data collection and management process including systems used can be found in the study Data Management Plan.
- Study monitors will perform ongoing source data verification to confirm that data entered into the CRF by authorized site personnel are accurate, complete, and verifiable from source documents; that the safety and rights of participants are being protected; and that the study is being conducted in accordance with the currently approved protocol and any other study agreements, ICH GCP, and all applicable regulatory requirements.

Records and documents, including signed ICF, pertaining to the conduct of this study must be retained by the investigator for 25 years from the issue of the final Clinical Study Report (CSR)/ equivalent summary unless local regulations or institutional policies require a longer retention period. No records may be destroyed during the retention period without the written approval of the sponsor. No records may be transferred to another location or party without written notification to the sponsor

#### **11.8.8. Source Documents**

- Source documents provide evidence for the existence of the participant and substantiate the integrity of the data collected. Source documents are filed at the investigator's site.
- Data reported on the CRF or entered in the eCRF that are transcribed from source documents must be consistent with the source documents or the discrepancies must be explained. The investigator may need to request previous medical records or transfer records, depending on the study. Also, current medical records must be available.

#### **11.8.9. Study and Site Closure**

GSK or its designee reserves the right to close the study site or terminate the study at any time for any reason at the sole discretion of GSK. Study sites will be closed upon study completion. A study site is considered closed when all required documents and study supplies have been collected and a study-site closure visit has been performed.

The investigator may initiate study-site closure at any time, provided there is reasonable cause and sufficient notice is given in advance of the intended termination.

Reasons for the early closure of a study site by the sponsor or investigator may include but are not limited to:

- Failure of the investigator to comply with the protocol, the requirements of the IRB/IEC or local health authorities, the sponsor's procedures, or GCP guidelines



- Inadequate recruitment of participants by the investigator
- Discontinuation of further study treatment development
- If GSK determines such action is needed, GSK will discuss the reasons for taking such action with the investigator or the head of the medical institution (where applicable). When feasible, GSK will provide advance notification to the investigator or the head of the medical institution, where applicable, of the impending action.
- Upon completion or premature discontinuation of the study, the GSK monitor will conduct site closure activities with the investigator or site staff, as appropriate, in accordance with applicable regulations including GCP, and GSK Standard Operating Procedures.
- If the study is suspended or prematurely discontinued for safety reasons, GSK will promptly inform all investigators, heads of the medical institutions (where applicable) and/or institution(s) conducting the study. GSK will also promptly inform the relevant regulatory authorities of the suspension or premature discontinuation of the study and the reason(s) for the action.
- If required by applicable regulations, the investigator or the head of the medical institution (where applicable) must inform the IRB/IEC promptly and provide the reason for the suspension or premature discontinuation.

#### **11.8.10. Records Retention**

- Following closure of the study, the investigator or the head of the medical institution (where applicable) must maintain all site study records (except for those required by local regulations to be maintained elsewhere), in a safe and secure location.
- The records must be maintained to allow easy and timely retrieval, when needed (e.g., for a GSK audit or regulatory inspection) and must be available for review in conjunction with assessment of the facility, supporting systems, and relevant site staff.
- Where permitted by local laws/regulations or institutional policy, some or all of these records can be maintained in a format other than hard copy (e.g., microfiche, scanned, electronic); however, caution needs to be exercised before such action is taken.
- The investigator must ensure that all reproductions are legible and are a true and accurate copy of the original and meet accessibility and retrieval standards, including re-generating a hard copy, if required. Furthermore, the investigator must ensure there is an acceptable back-up of these reproductions and that an acceptable quality control process exists for making these reproductions.
- GSK will inform the investigator of the time period for retaining these records to comply with all applicable regulatory requirements. The minimum retention time will meet the strictest standard applicable to that site for the study, as dictated by any institutional requirements or local laws or regulations, GSK standards/procedures, and/or institutional requirements.
- The investigator must notify GSK of any changes in the archival arrangements, including, but not limited to, archival at an off-site facility or transfer of

ownership of the records in the event the investigator is no longer associated with the site.

#### **11.8.11. Provision of Study Results to Investigators, Posting of Information on Publicly Available Clinical Trials Registers and Publication**

- Study information from this protocol will be posted on publicly available clinical trial registers before enrolment of participants begins.
- Where required by applicable regulatory requirements, an investigator signatory will be identified for the approval of the clinical study report. The investigator will be provided reasonable access to statistical tables, figures, and relevant reports and will have the opportunity to review the complete study results at a GSK site or other mutually-agreeable location.
- GSK will also provide the investigator with the full summary of the study results. The investigator is encouraged to share the summary results with the study participants, as appropriate.
- The procedures and timing for public disclosure of the results summary and for development of a manuscript for publication will be in accordance with GSK Policy.
- A manuscript will be progressed for publication in the scientific literature if the results provide important scientific or medical knowledge.

#### **Publication Policy**

- The results of this study may be published or presented at scientific meetings. If this is foreseen, the investigator agrees to submit all manuscripts or abstracts to the sponsor before submission. This allows the sponsor to protect proprietary information and to provide comments.
- The sponsor will comply with the requirements for publication of study results. In accordance with standard editorial and ethical practice, the sponsor will generally support publication of multicenter studies only in their entirety and not as individual site data. In this case, a coordinating investigator will be designated by mutual agreement.
- Authorship will be determined by mutual agreement and in line with International Committee of Medical Journal Editors authorship requirements.

## **11.9. Appendix 9: Country-Specific Requirements**

### **11.9.1. Study Duration**

In this study, the Extension Phase is intended to provide access to CAB LA + RPV LA Q4W or Q8W based on original randomization assignment until the regimen receives local (by country) Regulatory approval, and becomes commercially available. Therefore, the duration of the Extension Phase will vary from country to country and is dependent on the recruitment time for the study and the time taken to achieve local approval for marketing. During this time, participants will be monitored at minimum every 8 weeks to ensure they continue to derive clinical benefit from CAB LA + RPV LA.

## 11.10. Appendix 10: COVID-19 Pandemic and Clinical Trial Continuity

### Background

The COVID-19 pandemic presents significant logistical challenges for many clinical sites around the world, with variable restrictions being placed on site resources and operations, and on an individual participants ability to attend clinic visits. In some places, medical visits are occurring, and in others, research clinics are operating with only emergency staff.

Based on these challenges, it may be necessary to adopt additional measures and procedures to protect participant safety, and to ensure that there are no gaps in HIV-1 treatment for participants enrolled in this clinical study, through continuous access to antiretroviral therapy.

In order to maintain the scientific integrity of the study, and adhere to updated guidance from regulators, procedures have also been put into place to ensure that the actions taken to mitigate against any impact of COVID-19 are well documented in the trial database.

A “Memo to Investigators” was issued on March 18<sup>th</sup>, 2020 and served as a record of approved emergency actions being taken within this clinical trial to manage issues related to COVID-19. That memo continues to serve as record of approved actions which can be fully implemented by Investigators, in advance of this protocol guidance. This appendix will remain consistent with the guidance provided within the “Memo to Investigators” and will also serve to provide additional protocol documentation requirements and procedures.

This appendix outlines the measures which are approved for implementation within this clinical trial, to protect patient safety and to ensure the integrity of the clinical trial, as a result of COVID-19 only. These measures may be implemented in accordance with any requirements and expectations set out by local Independent Review Boards/Independent Ethics Committees (IRB/IEC) and National Competent Authorities (NCA), as necessary.

This appendix **does not** apply to participant management issues that are unrelated to a specific, and documented, impact from COVID-19.

### 11.10.1. Changes to Study Visits and Study Procedures

- Where site staff resource is constrained due to COVID-19, IM dosing visits may proceed with limited or no other protocol-defined assessments (e.g. lab tests, questionnaires, etc.). If lab tests will be missed for more than one consecutive visit, the medical monitor must be contacted, to provide guidance for safety monitoring.
- For WOCBP, point of care pregnancy testing should be performed, prior to IM dosing.
- If central laboratory testing cannot be performed at a particular visit, and monitoring for safety is required, tests may be performed at an appropriately

authorised/accredited local laboratory (or other relevant clinical facility), if this can be done within local restrictions on physical distancing. The site should proactively inform the sponsor about such instances. Local laboratory results may be used to inform safety decisions. Results should be retained in source records.

- When on-site visits are reduced, it is important that the investigator continue collecting relevant clinical information, including adverse events, from the participant through alternative means, e.g. by telephone contact.
- There may be cases where the current principal investigator (PI) of a site is indisposed for a period and may need to delegate parts of his/her duties temporarily, e.g. to a sub-investigator. Any such changes should be documented in the site's source records. Any permanent changes in PI should be communicated to the sponsor.
- There may also be circumstances where immediate actions are required by the sponsor and/or investigator, outside of what is contemplated in the protocol, in order to protect a study participant from immediate hazard. Any such measures will be carefully documented and conducted in accordance with the National Competent Authority (NCA)/IRB/IEC regulations.

### **11.10.2. Changes to Informed Consent**

Informed consent should continue per normal procedure and as described in the main body of the protocol, to the extent possible. However, there may be circumstances where re-consent of participants is needed, and a physical signature on site is not possible. In these cases, alternative ways of obtaining such re-consent should be considered, such as the participant sending a picture of his/her written consent to the investigator, or the investigator contacting the participant by telephone or video call and obtaining verbal consent, supplemented with email confirmation.

Any updated informed consent form or other subject-facing materials should be provided to participants by e-mail, mail or courier before re-consent is obtained. Any consent obtained this way should be documented in source records and confirmed by way of normal consent procedure at the earliest opportunity when participants attend their next on-site study visit.

Any alternative informed consent procedure must be undertaken only after site IRB/Ethics Committee agreement and approval.

### **11.10.3. Permissible Use of Antiretroviral Therapy**

In order to minimize the risk of gaps in HIV-1 antiretroviral therapy (ART) for participants impacted by COVID-19 in the clinical trial, the following options can be considered with regards to ART dosing, in order of preference:

1. Where possible, and safe to do, please continue to prioritize IM dosing visits in order to keep the participants on the protocol-defined regimen
  - a. Qualified healthcare professionals (HCPs) trained on study procedures can administer IM injections outside of the study clinic setting (e.g. home, nursing facility, hospital), assuming this can be done safely, without compromising investigational product preparation/handling/storage/accountability requirements and done in accordance with local requirements. Please seek approval by the study team on a case-by-case basis.
2. If a participant is not able to attend an IM injection visit due to COVID-19 related restrictions, the gap in IM dosing should be covered with oral ART, until IM dosing can resume. Participants should be reminded of the importance of adhering with daily oral dosing. Two options can be approved for oral bridging therapy in consultation with the Medical Monitor, listed in order of preference:
  - a. Oral CAB + RPV
    - i. Investigator should request availability of oral CAB + RPV supplies, prior to pursuing option b.
  - b. Oral standard of care (SOC) commercial ART (prescribed locally)

#### Oral bridging with CAB + RPV

The protocol permits oral bridging to cover planned missed injections with oral CAB + RPV, only until IM dosing can be resumed. The start date of oral bridging should be within the dosing window for the missed IM dosing visit. This recommendation can be used to accommodate requests for oral dosing due to COVID-19. Oral bridging recommendations should be followed as per protocol Section 6.8.1. The process and required information for requesting oral bridging can be found in your Study Reference Manual. Please continue to reach out to your study medical monitor for approval of oral bridging, in order to document use and to ensure expeditious shipment of oral CAB + RPV to your site.

Participants who use oral CAB + RPV as short-term oral bridging are permitted to return to IM dosing, on protocol, once the COVID-19 conditions permit resumption of site activities.

The investigator should reach out to the medical monitor to confirm IM restart instructions, and to ensure the participant remains appropriate for resumption of IM dosing. If oral bridging with CAB/RPV is anticipated to continue for > 2 months, additional approval and guidance should be obtained from the medical monitor to continue with oral bridging therapy. Loading/Re-initiation doses of CAB + RPV IM may be required, depending on the length of oral bridging.

### Oral bridging with Standard of Care Antiretroviral Therapy (SOC ART)

For participants impacted by COVID-19, where the participant is unable to receive IM injections, and oral CAB + RPV is not available for use, oral bridging with any commercially available, guideline-recommended, SOC ART regimen is permitted. The start date of oral bridging should be within the dosing window for the missed IM dosing visit. Please reach out to your study medical monitor for approval of SOC ART as oral bridging, in order to document the use of commercially available SOC ART within the study. In order to assure that participants have access to SOC ART during short-term oral bridging, GSK may allow for reimbursement of SOC ART or copayments as needed.

Participants who use oral SOC ART as short-term oral bridging as a result of COVID-19 will not be considered formally withdrawn insofar as they wish to continue on the study. Individuals who bridge with SOC ART will be permitted to return to IM dosing, on study, once the COVID-19 conditions permit resumption of site activities.

The investigator should reach out to the medical monitor to confirm IM restart instructions, and to ensure the participant remains appropriate for resumption of IM dosing. If oral bridging with SOC ART is anticipated to continue for > 2 months, additional approval and guidance should be obtained from the medical monitor to continue with oral bridging therapy. Loading/Re-initiation doses of CAB + RPV IM may be required, depending on the length of oral bridging.

#### **11.10.4. Direct-To-Patient (DTP) Shipment of Oral Study IP**

If a participant is unable to travel to the clinic, either to receive IM injections or to be dispensed oral bridging, sites are encouraged to consider DTP shipments of drug, from the site, to the participant, to ensure access to medicines.

- If the study site is considering DTP shipment of oral CAB + RPV investigational product (IP), the site must first verify if DTP IP dispensing by investigators/hospital pharmacies is locally permitted and whether it requires regulatory and/or local ethics pre-approval, or post-hoc notification.
- The study participant should express his/her agreement for DTP shipment and the sharing of their personal information with any third-party couriers (as applicable), in accordance with local requirements. This agreement should be documented in source records.
- Oral CAB + RPV IP can be shipped at ambient temperatures via ground transport without a temperature monitoring device, with low risk of temperature excursions. Sites are encouraged to use discretion in determining the need for in-transit temperature monitoring based on the labelled storage requirements and the planned mode of transport and apply this as appropriate. Shipment of oral CAB + RPV via air courier continues to require appropriate temperature monitoring. For shipment conditions of oral medications other than oral CAB + RPV, please consult the product labelling.
- In all cases IP accountability must be maintained, and all DTP dispensing documentation should be reflected in source records and dispensing logs per GCP.

- Please refer to your CRA or local study manager for support with the DTP process, ensuring reference to current sponsor guidance and arrangement of a courier that can support shipment of IMP directly to participants.

#### **11.10.5. COVID-19 Experimental Agents**

If any treatments for COVID-19 are planned for a study participant, please consult with the study medical monitor to ensure that relevant drug interactions are considered and to ensure that continued study participation remains appropriate.

#### **11.10.6. COVID-19 Specific Data Capture**

##### **11.10.6.1. Capturing COVID-19 Specific Protocol Deviations**

In order to summarise the impact of COVID-19 in a systematic way and in line with regulatory authorities' recommendations, any study-level impact around COVID-19 will be documented as a protocol deviation. This will include the permissible actions summarized in this Appendix, which are taken to protect patient safety, including the use of CAB + RPV or SOC ART as oral bridging as well as missed visits and assessments as a result of logistical challenges resulting from COVID-19.

Although the conduct of remote visits and the continuity of antiretroviral therapy, via oral bridging, are being utilized to protect patient safety, these events fall outside of the intent of the original protocol design, may have an impact on data interpretation, and thus will be characterized as protocol deviations for the purposes of data summary and analysis.

Any protocol deviations resulting from COVID-19 will be clearly identified as such within the protocol deviation description and summarised separately.

##### **11.10.6.2. Capturing COVID-19 Specific AEs and SAEs**

It is important for the study team to describe COVID-19 related adverse events/serious adverse events (AEs/SAEs) and their impact on study data and outcomes. Standardization of case definitions will facilitate future data analysis.

Please use the following guidance:

1. AEs should continue to be evaluated as to whether they meet SAE criteria as defined in the protocol, and if so, submitted according to established SAE reporting requirements. SAEs and AEs should be submitted following usual study procedures and timelines.
2. When an in-person clinic visit is not possible, please conduct a remote telehealth visit to assess for, and document any AEs/SAEs.
3. Investigators should use the WHO definition to classify COVID-19 cases. The definition below, released March 20, 2020, represents a time point for



standardized collection. We recognize definitions are likely to continue to evolve. When reporting both serious and non-serious adverse events (related to COVID-19 infection, investigators should use the following Verbatim terms:

- a) Suspected COVID-19 infection; or
  - b) Probable COVID-19 infection; or
  - c) Confirmed COVID-19 infection
4. Sites should contact the study Medical Monitor for questions related to definitions and reporting, and decisions around impact to study drug continuation.
  5. A new COVID-19 infection Case Report Form will be added to the eCRF to collect additional details about the reported COVID-19 AE or SAE data. It is important to collect the correct information from each participant reporting a COVID-19 AE or SAE. Therefore, please use the CRF templates to help you collect this information, once available.

**WHO Case Definition - March 20, 2020 Version** ([https://www.who.int/publications-detail/global-surveillance-for-human-infection-with-novel-coronavirus-\(2019-ncov\)](https://www.who.int/publications-detail/global-surveillance-for-human-infection-with-novel-coronavirus-(2019-ncov))):

**Suspected case:**

- A. A patient with acute respiratory illness (fever and at least one sign/symptom of respiratory disease, e.g., cough, shortness of breath), AND a history of travel to or residence in a location reporting community transmission of COVID-19 disease during the 14 days prior to symptom onset;

OR

- B. A patient with any acute respiratory illness AND in contact (see definition of “contact” below) with a confirmed or probable COVID-19 case (see definition of contact) in the last 14 days prior to symptom onset;

OR

- C. A patient with severe acute respiratory illness (fever and at least one sign/symptom of respiratory disease, e.g., cough, shortness of breath; AND requiring hospitalization) AND in the absence of an alternative diagnosis that fully explains the clinical presentation.

**Probable case:**

- A. A suspect case for whom testing for the COVID-19 virus is inconclusive (Inconclusive being the result of the test reported by the laboratory).

OR

- B. A suspect case for whom testing could not be performed for any reason.

**Confirmed case:**

A person with laboratory confirmation of COVID-19 infection, irrespective of clinical signs and symptoms.

**Covid-19 Contact:**

A contact is a person who experienced any one of the following exposures during the 2 days before and the 14 days after the onset of symptoms of a probable or confirmed case:

1. Face-to-face contact with a probable or confirmed case within 1 meter and for more than 15 minutes;
2. Direct physical contact with a probable or confirmed case;
3. Direct care for a patient with probable or confirmed COVID-19 disease without using proper personal protective equipment; OR
4. Other situations as indicated by local risk assessments.

Note: For confirmed asymptomatic cases, the period of contact is measured as the 2 days before through the 14 days after the date on which the sample was taken which led to confirmation.

## **11.11. Appendix 11: Information and Guidance for Managing Pregnant Participants**

### **11.11.1. Collection of Pregnancy Information**

**The Investigator will collect pregnancy information on any female participant who becomes pregnant while participating in this study.**

- Information will be recorded on the appropriate form and submitted to GSK within 24 hours of learning of a participant's pregnancy.
- Participant will be followed to determine the outcome of the pregnancy. The investigator will collect follow-up information on mother and infant, which will be forwarded to GSK. Generally, follow-up will not be required for longer than 6 to 8 weeks beyond the estimated delivery date.
- Any termination of pregnancy will be reported, regardless of fetal status (presence or absence of anomalies) or indication for procedure.
- While pregnancy itself is not considered to be an AE or SAE, any pregnancy complication or elective termination of a pregnancy for medical reasons will be reported as an AE or SAE.
- A spontaneous abortion is always considered to be an SAE and will be reported as such.
- Any SAE occurring as a result of a post-study pregnancy which is considered reasonably related to the study treatment by the investigator, will be reported to GSK as described in the protocol in Section 7.4.3. While the investigator is not obligated to actively seek this information in former study participants, he or she may learn of an SAE through spontaneous reporting.
- Females who become pregnant while in the study may remain in study, and continue scheduled dosing with CAB + RPV LA, once a pregnancy ICF addendum is signed by the participant.

### **11.11.2. Introduction**

Pregnancy increases the risk of HIV progression, while HIV increases the risk for maternal complications from pregnancy and poses the risk of perinatal HIV transmission to the unborn fetus. Mother to child transmission (MTCT) of HIV can occur during pregnancy, labor, delivery or postpartum through breastfeeding. In the absence of any interventions, vertical HIV transmission rates approximate 35%, but fall below 5% with effective interventions [WHO, 2010]. In the United States and other developed countries, the risk of perinatal infection has decreased from 25% without intervention to less than 2% with intervention [WHO, 2012]. The HIV-infected mother who breastfeeds her infant while taking ARVs herself or giving ARVs to her infant reduces the risk of transmission to about 2% after 6 months of breastfeeding, or 4% over 12 months [UNAIDS, 2011].

The 2013 WHO Guidelines thus recommend (strong recommendation, moderate-quality evidence) all pregnant and breastfeeding women with HIV should initiate triple ARVs

(ART), which should be maintained at least for the duration of mother-to-child transmission risk. Women meeting treatment eligibility criteria should continue lifelong ART [WHO, 2013]. The global benefits anticipated from ART in pregnant women who are eligible for treatment include treatment of the mother's underlying HIV disease, eliminating pediatric transmission/infection and reducing sexual transmission of HIV

Recent recommendation updates to treatment guidelines have included objectives to increase HIV screening of patients, including pregnant women (noting the importance of adopting HIV screening to be a part of prenatal care).

The ART recommendation for pregnant females prioritizes the health of women over potential risks and increased cost. For females who are on ARV therapy at the time that they become pregnant, the World Health Organization recommends that they continue such therapy if they are responding to the ARV.

In line with this recommendation, this study will allow those females participating in 207966 who are receiving CAB + RPV LA but become pregnant on study, to continue in the study in order to maintain their effective regimen with minimal disruption. The PK of CAB + RPV LA, characterization of the safety of CAB + RPV LA administered during pregnancy, and characterization of maternal, birth and infant outcomes following treatment with CAB + RPV LA will be examined.

### **11.11.3. Benefit/Risk Assessment**

Discuss with pregnant participant the benefit-risk of continuing in the study and continuing to receive CAB + RPV LA injections, or being withdrawn from study, as a result of her pregnancy. All participants who chose to stay in the study during pregnancy, and who choose to continue to receive CAB + RPV LA injections will need to sign a pregnancy specific ICF addendum.

There is a pregnancy exposure registry that monitors pregnancy outcomes in women exposed to CAB + RPV LA (CABENUVA) during pregnancy. Healthcare providers are encouraged to register all pregnant study participants, whether or not they choose to remain in the study, by calling the Antiretroviral Pregnancy Registry [Antiretroviral Pregnancy Registry (APR) Steering Committee, 2013] at 1-800-258-4263.

#### **11.11.3.1. Cabotegravir**

Cabotegravir use in pregnant females has not been evaluated and there are insufficient human data on the use of during pregnancy to adequately assess a drug-associated risk of birth defects and miscarriage.

The rate of miscarriage is not reported in the APR. The background risk for major birth defects and miscarriage for the indicated population is unknown. The background rate for major birth defects in a U.S. reference population of the Metropolitan Atlanta Congenital Defects Program (MACDP) is 2.7%. The estimated background rate of miscarriage in clinically recognized pregnancies in the U.S. general population is 15% to 20%. The APR uses the MACDP as the U.S. reference population for birth defects in the general

population. The MACDP evaluates women and infants from a limited geographic area and does not include outcomes for births that occurred at less than 20 weeks' gestation.

### ***Animal Data (pre-clinical)***

Cabotegravir was administered orally to pregnant rats at 0, 0.5, 5, or 1,000 mg/kg/day from 15 days before cohabitation, during cohabitation, and from Gestation Days 0 to 17. There were no effects on fetal viability when fetuses were delivered by caesarean although a minor decrease in fetal body weight was observed at 1,000 mg/kg/day (greater than 30 times the exposure in humans at the RHD). No drug-related fetal toxicities were observed at 5 mg/kg/day (approximately 13 times the exposure in humans at the RHD) and no drug-related fetal malformations were observed at any dose.

Cabotegravir was administered orally to pregnant rabbits at 0, 30, 500, or 2,000 mg/kg/day from Gestation Days 7 to 19. No drug-related fetal toxicities were observed at 2,000 mg/kg/day (approximately 0.7 times the exposure in humans at the RHD).

In a rat pre- and postnatal development study, cabotegravir was administered orally to pregnant rats at 0, 0.5, 5, or 1,000 mg/kg/day from Gestation Day 6 to Lactation Day 21. A delay in the onset of parturition and increases in the number of stillbirths and neonatal deaths by Lactation Day 4 were observed at 1,000 mg/kg/day (greater than 30 times the exposure in humans at the RHD); there were no alterations to growth and development of surviving offspring. In a cross-fostering study, similar incidences of stillbirths and early postnatal deaths were observed when rat pups born to cabotegravir-treated mothers were nursed from birth by control mothers. There was no effect on neonatal survival of control pups nursed from birth by cabotegravir-treated mothers. A lower dose of 5 mg/kg/day (13 times the exposure at the RHD) was not associated with delayed parturition or neonatal mortality in rats. Studies in pregnant rats showed that cabotegravir crosses the placenta and can be detected in fetal tissue.

During the pre-clinical development of CAB, there were no positive genotox findings. Embryo-fetal studies also showed no adverse findings including neural tube defects. In a pre and postnatal study, there were some test article-related decreases in F1 pup survival (87.4% vs 98.9% in control) in the highest dose (1000 mg/kg/day) during postnatal days 1-4. No findings in the 0, 0.5 and 5 mg/kg/day doses).

The clinical significance of these finding in humans is unknown.

### ***Human Data***

Cabotegravir use in pregnant females has not been evaluated and there are insufficient human data on the use of CAB + RPV LA during pregnancy to adequately assess a drug-associated risk of birth defects and miscarriage.

While there are insufficient human data to assess the risk of neural tube defects (NTDs) with exposure to CAB + RPV LA during pregnancy, preliminary findings from an unscheduled analysis of a birth outcomes surveillance study conducted in Botswana (Tsepamo Study) and presented in May 2018 showed a higher than expected number of neural tube defects (NTDs) among newborns whose mothers were exposed to DTG based

ART at conception. DTG is a different molecule in the same integrase class of medications as CAB. As of May 2018 four cases of neural tube defects were identified in 426 infants born to mothers who were exposed to DTG-containing regimens from the time of conception. In the same study, no infant born to a woman who started DTG during pregnancy had a neural tube defect, out of 2,824 women. Updated analysis of interim data from the Tsepamo study became available in 2019 and more recently in 2020. Subsequently, the study team presented an updated analysis, including data through to 30 April 2020, at the 23<sup>rd</sup> International AIDS Society (IAS) Meeting [[Zash, 2020](#)].

The latest data from the Tsepamo study included additional data accrued between 1 April 2019 (the cut-off for the last formal analysis) and 30 April 2020. Over this 13-month period, 39,200 additional births were recorded, including 1908 additional exposures to DTG at conception. Two additional NTDs were detected in 1908 (0.10%) deliveries to mothers taking DTG at conception, compared with six NTDs in 4569 (0.13%) deliveries in mothers taking non-DTG regimens at conception, of which five NTDs in 2999 (0.17%) deliveries were to mothers taking efavirenz at conception. The incidence in HIV negative mothers over the 13-month period was 17/30,258 (0.06%).

As of the Tsepamo Apr 2020 analysis, seven cases of neural tube defects were reported in 3,591 deliveries (0.19%) to mothers taking dolutegravir -containing regimens at the time of conception, compared with 21 cases in 19,361 deliveries (0.11%) to mothers taking non- dolutegravir containing regimens at the time of conception (Prevalence Difference 0.09%; 95% CI -0.03, 0.30). Since first analysis, the estimated prevalence of neural tube defects with DTG exposure at conception has decreased in magnitude from 0.94% to 0.19%. In the same study, no increased risk of neural tube defects was reported in women who started dolutegravir during pregnancy. Two out of 4,448 deliveries (0.04%) to mothers who started dolutegravir during pregnancy had a neural tube defect, compared with five out of 6,748 deliveries (0.07%) to mothers who started non-dolutegravir - containing regimens during pregnancy.

A causal relationship of these events to the use of DTG has not been established.

The incidence of neural tube defects in the general population ranges from 0.5-1 case per 1,000 live births. There are insufficient human data on the use of CAB + RPV LA during pregnancy to adequately assess a drug-associated risk of miscarriage or birth defects, including NTDs.

### 11.11.3.2. Rilpivirine

#### ***Animal Data***

Rilpivirine was administered orally to pregnant rats (40, 120, or 400 mg/kg/day) and rabbits (5, 10, or 20 mg/kg/day) through organogenesis (on Gestation Days 6 through 17, and 6 through 19, respectively). No significant toxicological effects were observed in embryo-fetal toxicity studies performed with rilpivirine in rats and rabbits at exposures 15 (rats) and 70 (rabbits) times the exposure in humans at the RHD. In a pre- and postnatal development study, rilpivirine was administered orally up to 400 mg/kg/day through lactation. No adverse effects were noted in the offspring at maternal exposures up to 63 times the exposure in humans at the RHD

#### ***Human Data***

Based on prospective reports to the APR of over 390 exposures to oral rilpivirine-containing regimens during the first trimester of pregnancy and over 170 during second/third trimester of pregnancy, the prevalence of birth defects in live births was 1.3% (95% CI: 0.4% to 3.0%) and 1.1% (95% CI: 0.1% to 4.0%) following first and second/third trimester exposures.

Available data from the APR show no difference in the overall risk of birth defects for rilpivirine compared with the background rate for major birth defects of 2.7% in a U.S. reference population of the Metropolitan Atlanta Congenital Defects Program (MACDP)

In a clinical trial, total oral rilpivirine exposures were generally lower during pregnancy compared with the postpartum period. Refer to the current Edurant Prescribing Information for additional information on rilpivirine ([Edurant Prescribing Information](#), 2018).

### 11.11.4. Clinical Considerations

#### 11.11.4.1. Exposure

Lower exposures with oral rilpivirine were observed during pregnancy. Cabotegravir and rilpivirine are detected in systemic circulation for up to 12 months or longer after discontinuing injections of CAB + RPV LA; therefore, consideration should be given to the potential for fetal exposure during pregnancy.

With the change in volume of distribution associated with pregnancy, drug concentrations of CAB and RPV during pregnancy will be assessed in pregnant participants who continue to receive LA therapy while on study. For these participants, plasma PK samples of CAB and RPV will be obtained at every study visit for Q8W and Q4W during the pregnancy and at the first postpartum LA injection visit. Viral load testing and Clinical Chemistry will also be collected at every study visit during the pregnancy and at the first postpartum LA injection visit. Additionally, all other scheduled assessments, will continue as reflected in as described in the protocol in the Time and Events Table (see Section 7.1)

**Figure 18 LTFU PK in Female and Pregnant Participants (LATTE-2, ATLAS)**

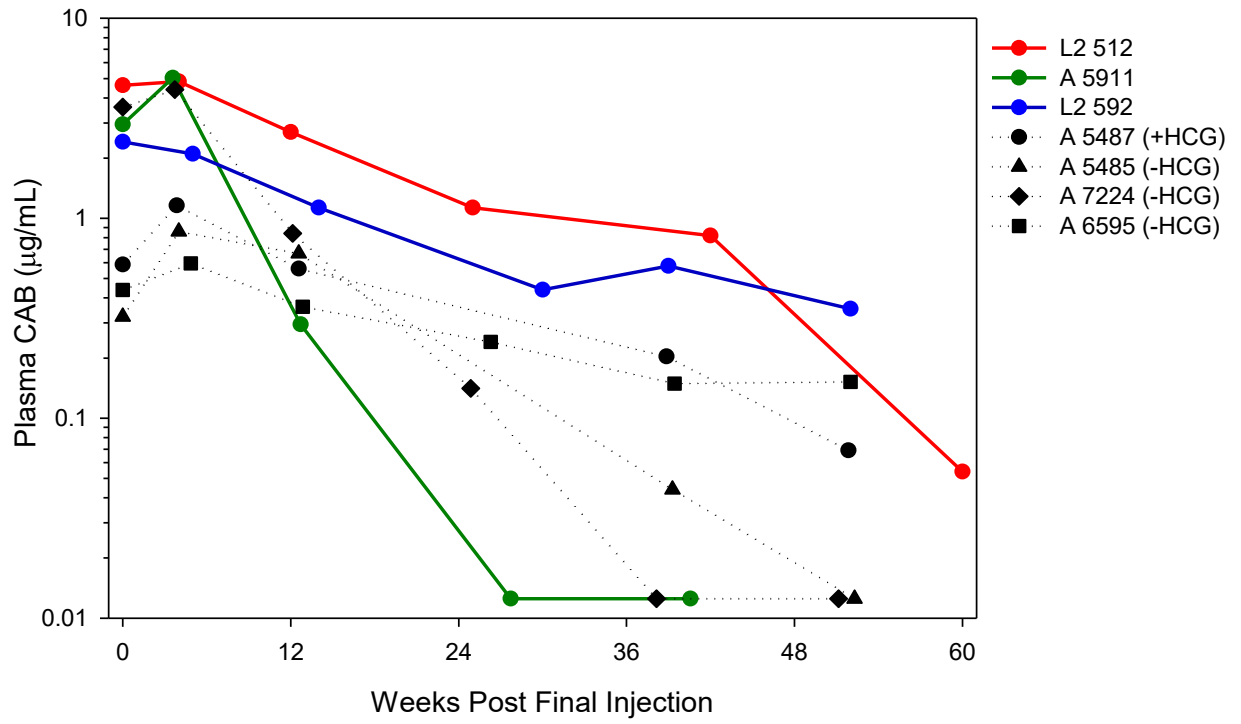



#### **11.11.4.2. Use of Supplements with CAB + RPV LA**

During pregnancy, additional supplements including vitamins, minerals and other medications including OTC meds may be prescribed to the pregnant woman. It is important for all female participants who remain in the study to be aware of any potential DDIs that may occur with study medications and other agents used during pregnancy.

##### **11.11.4.2.1. Oral Cabotegravir Only**

**Antacid products containing divalent cations (e.g., aluminium, calcium and magnesium) must be taken at least 2 hours before or at least 4 hours after CAB.**

Concurrent administration of multivitamins is acceptable.

#### **11.11.4.3. Overall Benefit: Risk Conclusion**

All medications have AE profiles that must be assessed prior to use, allowing for an appropriate risk/benefit assessment. Additional considerations when using CAB + RPV LA can be found in the protocol in Section 2.3.

There is limited data regarding the use of CAB + RPV LA in pregnant females. Based on animal data, the use of CAB + RPV LA is not anticipated to increase the risk of adverse developmental or reproductive outcomes in humans. Available data from the APR show no difference in the overall risk of birth defects for rilpivirine compared with the background rate for major birth defects of 2.7% in a U.S. reference population of the Metropolitan Atlanta Congenital Defects Program (MACDP).

Refer to Section 11.11.3 for additional data.

The use of CAB + RPV LA during pregnancy may offer unique benefits. It is well documented that treatment adherence challenges to oral therapy exists both in the peri-partum and post-partum periods with LA dosing offering an opportunity to overcome such adherence challenges. LA therapy may also help with nausea (50 % mild to moderate) or hyperemesis (2%). Female participants on LA dosing who become pregnant will have exposures throughout pregnancy due to the long half-life and PK tail of CAB/RPV. Pregnant participants who are withdrawn from study and are initiated on an alternative oral ART regimen consisting of either 2 or 3 antiretrovirals to protect the life of the mother and for the prevention of MTCT, potentially expose the fetus to additional ARVs during gestation (in some cases upwards of 5 antiretrovirals).

In summary, while the 207966 protocol still mandates effective contraception for all WOCP, if a woman does become pregnant while on study, a benefit/risk assessment between the treating physician and the study participant regarding whether to continue on study will be undertaken. Allowing women who become pregnant to stay on study will abrogate the need to add additional ART agents to maintain VL suppression if such a woman was to be withdrawn from study and LA dosing.

Given the risk/benefit ratio for CAB + RPV LA dosing in WOCP, coupled with concerns of increasing fetal exposure to several additional antiretrovirals upon participant

withdrawal, pregnant participants will be allowed to remain in the study and continue to receive CAB + RPV LA injections, once the new pregnancy ICF addendum is signed by the participant.

#### **11.11.5. Study Assessments and Procedures: specific assessments for pregnant participants**

Participants who become pregnant while in the study, and who sign the informed consent pregnancy addendum may remain in the study and continue to receive CAB + RPV LA.

**Please note:** The HIV provider is responsible for HIV care and will collaborate and share information with the subject's obstetric care provider, discuss the subject's participation in this study, the necessary procedures at delivery, to share HIV information, and to collect birth and infant outcomes from the subject's obstetric care provider and/or the pediatric health provider for the infant.

Because obstetric and/or pediatric care will not be specifically provided via this study, the subject must also establish appropriate obstetric and pediatric care (including prenatal care) per local standard of care (SoC) in parallel. It will be necessary for the subject to provide a release of medical information to facilitate collection of pregnancy and pregnancy outcomes by the investigator

In addition to the assessments mentioned in this appendix, the rest of the study assessments will be conducted in accordance with the protocol, as described in the protocol in the Time and Events Table (see Section [7.1](#))

##### **11.11.5.1. Safety Assessments**

All pregnant participants who elect to remain in the study will have the following samples obtained at each LA injection visit throughout the pregnancy and at the first postpartum LA injection visit.

- HIV-1 RNA
- Clinical Chemistry

Pregnancy related complications and diagnoses, and outcomes will be captured as AEs and SAEs as outlined in the protocol in section [7.4.3](#).

Pregnancy complications (e.g., preeclampsia or eclampsia, prolonged hospitalization after delivery, for wound infections etc, seizures) and elective terminations for medical reasons must be reported as an AE or SAE. Spontaneous abortions must be reported as an SAE.

In the event of a pregnancy loss, after the loss is confirmed the subject may continue to receive CAB + RPV LA unless they meet the criteria for confirmed virologic withdrawal. They may continue to CAB + RPV LA until study medications are locally approved and commercially available or until they no longer receive benefit. In this case the subject must agree to use contraception to avoid a 'new' pregnancy (See [Appendix 7](#)).

Any SAE occurring in association with the pregnancy brought to the investigator's attention after the subject has completed the study and considered by the investigator as possibly related to the study treatment, must be promptly reported to GSK

#### **11.11.5.2. Pharmacokinetics**

Refer to section 7.5 in the protocol

All pregnant participants who elect to remain in the study will have the following PK samples obtained at each LA injection visit throughout the pregnancy and at the first postpartum LA injection visit:

- Blood samples for evaluation of total CAB (2mL each) and total RPV (2mL each) plasma concentrations.
- Blood sample for evaluation of unbound CAB (9mL each) plasma PK concentration.

. All PK samples will be trough levels and will be collected prior to the scheduled LA injection. The pre-dose trough PK sample is to be collected within 15 minutes prior to the LA dose, on the day of the study visit.

For participants pregnant during the Long Term Follow Up phase, plasma concentrations of cabotegravir and rilpivirine will be collected as per Section 7.1 Time and Events table.

Please refer to the SPM for PK sample collection, processing, and shipping instructions. The actual date and time of each PK sample collection will be recorded in the eCRF.

#### **11.11.6. References**

Antiretroviral Pregnancy Registry (APR) Steering Committee. Antiretroviral Pregnancy Registry International Interim Report for 1 January 1989 through 31 January 2013. Wilmington, NC: Registry Coordinating Center; 2013. Available from URL: [www.APRegistry.com](http://www.APRegistry.com).

Edurant Prescribing Information, February 2018

UNAIDS (2011) Reference Group on Estimates, Modelling and Projections. Working Paper on Mother-to-Child HIV Transmission Rates for use in Spectrum, 6 June 2011. Available online at <http://www.epidem.org/Publications/MTCTratesworkingpaper.pdf>.

World Health Organization (WHO) (2010). Antiretroviral drugs for treating pregnant women and preventing HIV infection in infants: Recommendations for a public health approach. Available online at: [http://whqlibdoc.who.int/publications/2010/9789241599818\\_eng.pdf](http://whqlibdoc.who.int/publications/2010/9789241599818_eng.pdf), accessed 6 Feb 2013.

World Health Organization (WHO) (2012). Antiretroviral Treatment as Prevention (TasP) of HIV and TB: 2012 Update. June 2012, Available online at: [http://www.who.int/hiv/pub/mtct/programmatic\\_update\\_tasp/en/index.html](http://www.who.int/hiv/pub/mtct/programmatic_update_tasp/en/index.html)

World Health Organization (WHO) (2013). Consolidated Guidelines on the Use of Antiretroviral Drugs for Treating and Preventing HIV Infection. 30 June 2013. Available online at: <http://www.who.int/hiv/pub/guidelines/arv2013/download/en/index.html>

Zash R, Holmes L, Diseko M, Jacobson D, Mayondi G. Update on neural tube defects with antiretroviral exposure in the Tsepamo study, Botswana. JAIDS 2020.

## 11.12. Appendix 12: Device Deficiencies: Definition and Procedures for Recording, Evaluating, Follow-up, and Reporting in Medical Device Studies

The definitions and procedures detailed in this appendix are in accordance with ISO 14155 and the European Medical Device Regulation (MDR) 2017/745 for clinical device research, and the US Food and Drug Administration (FDA) combination product reporting rule, 21 CFR 4, Subpart B.

Both the investigator and the sponsor will comply with all local medical device reporting requirements for medical devices.

The detection and documentation procedures described in this protocol apply to all medical devices used in the study (see Section 6.14 for the list of medical devices).

### 11.12.1. Definition of Device Deficiency

#### Device Deficiency Definition

- A device deficiency is an inadequacy of a medical device with respect to its identity, quality, durability, reliability, safety, or performance. Device deficiencies include malfunctions, use errors, and inadequacy of the information supplied by the manufacturer.

### 11.12.2. Recording and Follow-Up of AE and/or SAE and Device Deficiencies

#### AE, SAE and Device Deficiency Recording

- When a device deficiency occurs, with or without an associated AE/SAE, it is the responsibility of the investigator to review all applicable documentation (e.g., hospital progress notes, laboratory reports, and diagnostics reports) related to the event.
- The investigator will then record all relevant device deficiency information on the appropriate form. If applicable, any associated AE or SAE will be documented in the participant's medical records, in accordance with the investigator's standard clinical practice. There may be instances when copies of medical records for certain cases are requested by the sponsor. In this case, all participant identifiers, with the exception of the participant number, will be redacted on the copies of the medical records before submission to the sponsor.
- The investigator will attempt to fully describe the device deficiency and provide details on any treatment provided.
- For device deficiencies, it is very important that the investigator describe any corrective or remedial actions taken to prevent the deficiency's recurrence.
  - A remedial action is any action other than routine maintenance or servicing of a medical device where such action is necessary to prevent the recurrence of a device deficiency. This includes any amendment to the device design to

prevent recurrence.
<b>Assessment of Intensity of associated AE/SAEs</b>
<ul style="list-style-type: none"> <li>If an AE or SAE is associated with a device deficiency, the investigator will make an assessment of intensity for each AE or SAE as outlined in Section 7.4.3</li> </ul>
<b>Follow-up of device deficiency</b>
<ul style="list-style-type: none"> <li>The investigator is obligated to perform or arrange for the conduct of supplemental measurements and/or evaluations as medically indicated or as requested by the sponsor to elucidate the nature of the device deficiency and any associated AE or SAE as fully as possible</li> <li>New or updated information regarding the device deficiency will be recorded in the originally completed medical device deficiency report form.</li> <li>If there is an associated SAE with the device deficiency, the investigator will submit any updated SAE data to GSK within 24 hours of receipt of the information.</li> </ul>

### 11.12.3. Reporting of Medical Device Deficiencies for participants

<b>Reporting to GSK</b>
<ul style="list-style-type: none"> <li>NOTE: There are additional reporting obligations for medical device deficiencies that are potentially related to SAEs that must fulfill the legal responsibility to notify appropriate regulatory authorities and other entities about certain safety information relating to medical devices being used in clinical studies.</li> <li>Medical device deficiencies that are not related to an AE or SAE should be reported via email to <a href="mailto:gsk-rd.complaints@gsk.com">gsk-rd.complaints@gsk.com</a>, using the medical device deficiency report form.</li> <li>If the medical device deficiency is related to a non-serious AE and not linked to an SAE, please send the medical device deficiency report form via email to <a href="mailto:gsk-rd.complaints@gsk.com">gsk-rd.complaints@gsk.com</a> only. The eCRF for the subject should also be updated with AE information, as outlined in Section 7.4.3</li> <li>If the device incident is linked to an SAE, please email the medical device deficiency report form, within 24 hours, to <b>both</b> <a href="mailto:uk.gsk-rd-gcsp-ctsm-admin@gsk.com">uk.gsk-rd-gcsp-ctsm-admin@gsk.com</a> (or fax +44(0)20 8754 7822) <b>and</b> <a href="mailto:gsk-rd.complaints@gsk.com">gsk-rd.complaints@gsk.com</a>. The SAE form should also be reported, as outlined in Section 7.4.3. The eCRF for the subject should also be updated with the SAE information.</li> <li>GSK will review all device deficiencies and determine and document in writing whether they could have led to an SAE. These device deficiencies will be reported to the regulatory authorities and IRBs/IECs as required by national regulations.</li> <li>Contacts for Medical Device Deficiency reporting can be found in the medical device deficiency report form.</li> </ul>

#### 11.12.4. Reporting of Medical Device Deficiencies for Associated Person

##### Reporting to GSK

If an Associated Person (i.e. spouse, caregiver, site staff...) experiences a device deficiency, the medical device deficiency information and any associated AE/SAE information will be reported to GSK. The associated person will be provided with the safety reporting information and authorization to contact physician letter.

If follow up is required, authorization to contact physician (or other licensed medical practitioner) must be signed to obtain consent.

- Medical device deficiencies that are not related to an AE or SAE should be reported via email to [gsk-rd.complaints@gsk.com](mailto:gsk-rd.complaints@gsk.com), using the medical device deficiency report form.
- If the medical device deficiency is related to a non-serious AE and not linked to an SAE, please send the medical device deficiency report form with details of the associated AE via email to [gsk-rd.complaints@gsk.com](mailto:gsk-rd.complaints@gsk.com) only.
- If the device incident is linked to an SAE, please email the medical device deficiency report form, within 24 hours, to **both** [uk.gsk-rd-gcsp-ctsm-admin@gsk.com](mailto:uk.gsk-rd-gcsp-ctsm-admin@gsk.com) (or fax +44(0)20 8754 7822) **and** [gsk-rd.complaints@gsk.com](mailto:gsk-rd.complaints@gsk.com). The associated SAE form should also be reported to [uk.gsk-rd-gcsp-ctsm-admin@gsk.com](mailto:uk.gsk-rd-gcsp-ctsm-admin@gsk.com) (or fax +44(0)20 8754 7822).
- GSK will review all device deficiencies and determine and document in writing whether they could have led to an SAE. These device deficiencies will be reported to the regulatory authorities and IRBs/IECs as required by national regulations.
- Contacts for Medical Device Deficiency reporting can be found in the medical device deficiency report form.

## **11.13. Appendix 13: Vastus Lateralis Muscle (Thigh) PK sub-study Amendment**

### **TITLE PAGE**

**Parent Study Protocol Title:** A Phase IIIb, Randomized, Multicenter, Parallel-group, Non-inferiority, Open-label Study Evaluating the Efficacy, Safety, and Tolerability of Long-acting Cabotegravir Plus Long-acting Rilpivirine Administered Every 8 Weeks or Every 4 Weeks in HIV-1-infected Adults who are Virologically Suppressed (ATLAS-2M), further referred to as A2M.

**Sub-study Protocol Amendment Title:** Sub-study to the A2M study to Evaluate the Pharmacokinetics, Tolerability and Efficacy of Cabotegravir and Rilpivirine Long-Acting Injections Following Intramuscular Administration in the Vastus Lateralis Muscle (thigh) in HIV-infected Adult Participants who have Received at Least Three Years of Gluteal Injections in the A2M Study.

#### **11.13.1. Sub-study Amendment Background**

Cabotegravir/rilpivirine (CAB/RPV) long acting (LA) has been approved for the treatment of HIV-1 infection as a complete regimen in adults to replace the current antiretroviral regimen in many geographical regions of the world including the United States, Canada, Europe and Australia with additional countries approaching regulatory approval. CAB/RPV LA is administered via gluteal injections for monthly or every two months dosing for clinic-based administration by a Health Care Provider (HCP). As more patients are experiencing this new treatment paradigm, it is becoming apparent that HIV stigma and issues surrounding HIV disclosure, while improved, have not totally been eradicated. As more HIV infected individuals opt for LA therapy to control their HIV infection, many patient groups and other activist communities are requesting continued research and development in alternative injection sites. These measures may improve overall treatment compliance for patients with difficulty adhering to monthly or every other month office visits and may improve any residual stigma that patients may still be experiencing during their engagement with various healthcare systems.

An ongoing Phase 1, healthy volunteer open-label study (208832) is evaluating the pharmacokinetics (PK) and tolerability of cabotegravir and rilpivirine long-acting injections following intramuscular administration in the vastus lateralis muscle (further referred to as thigh) in 15 study participants (n= 9 male, n=6 female; BMI (kg/m<sup>2</sup>) median 30.3). All subjects received a 4-week oral lead in (OLI) with daily cabotegravir 30 mg and rilpivirine 25 mg, and after a two week wash out, 14 participants received single 600 mg CAB LA and 900 mg RPV LA injections. One participant was withdrawn after the OLI phase and before injection due to confirmed pregnancy.

PK sampling for measurement of plasma CAB and RPV in this on-going Phase 1 study was performed at the following timepoints: D1, 2, 4, 5, 7, 8, 10, 15, 17, 22, 28 (week 4) post injection with longer term PK evaluations also obtained at weeks 8, 12, 24, 36, and 52 post the single CAB/RPV injections. Safety and tolerability data through week 12



demonstrated good overall tolerability with all 14 subjects receiving injections experiencing ISRs of limited duration (mostly pain at the injection site with a few subjects experiencing erythema and induration at the injection site). Of the 14 ISRs, 13 were judged by the investigator as mild and one considered moderate (pain and erythema at the injection site). Additionally, one subject with mild ISR of pain also had bilateral hip pain after injection and a mild elevation of AST (84 UL/L) and ALT (74 UL/L). This subject had a confirmed diagnosis of COVID-19 infection raising the possibility that the constellation of signs and symptoms may be secondary to infection with SARS-COV-2. Overall, laboratory abnormalities were minimal with mild and transient ALT elevations noted for some subjects. All ALT elevations returned to baseline levels during the study except for one subject who continued with fluctuating ALT elevations, with the highest value reported for ALT of 97 UL/L and for AST of 106 UL/L.

PK data through 12 weeks post injections was evaluated and considered supportive of further studies of thigh administration in HIV-infected individuals. When compared to the simulated CAB plasma concentrations following gluteal administration of CAB LA 600 mg (accounting for covariates), observed CAB plasma concentrations following 600 mg of CAB LA to the lateral thigh were slightly higher than the predicted at 1-week (~Cmax) and 4-weeks post injection but similar to the predicted at 8-weeks post injection. These differences may have resulted from slightly faster absorption via thigh administration than gluteal administration for CAB LA. RPV plasma concentrations following 900 mg of RPV to the lateral thigh were consistent with predictions following RPV gluteal administration.

**Figure 19 Preliminary CAB Concentrations following a Single 600 mg IM injection to the lateral thigh (n=14) Phase 1 Study 208832**

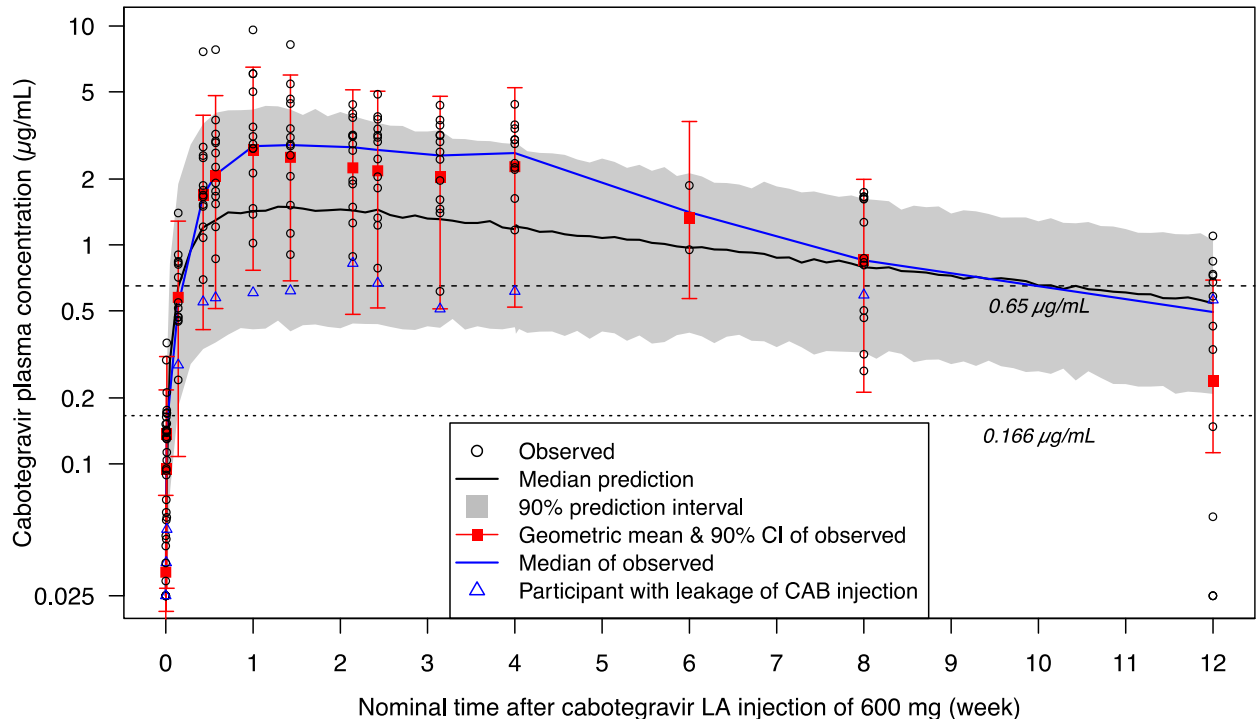

Covariates were resampled 1000 times from the participants in the thigh PK study (n=14), generating 1000 virtual subjects. Individual PK parameters of the virtual subjects were calculated using subject-specific covariates and using the population parameter estimates including residual variability, subject-specific NONMEM inter-individual errors (ETAs) sampled from the distributions that are decided by the estimated variance-covariate matrix of between-subject variability from the final PopPK model. Concentration-versus-time profiles of the virtual subjects were calculated using the individual PK parameters of the virtual subjects following a single CAB LA injection of 600 mg. Median and 5th and 95th percentiles of the simulated concentration-versus-time profiles of the virtual subjects were calculated and plotted.

**Figure 20 Preliminary RPV Concentrations following a Single 900 mg IM injection to the lateral thigh (n=14) Phase 1 Study 208832**

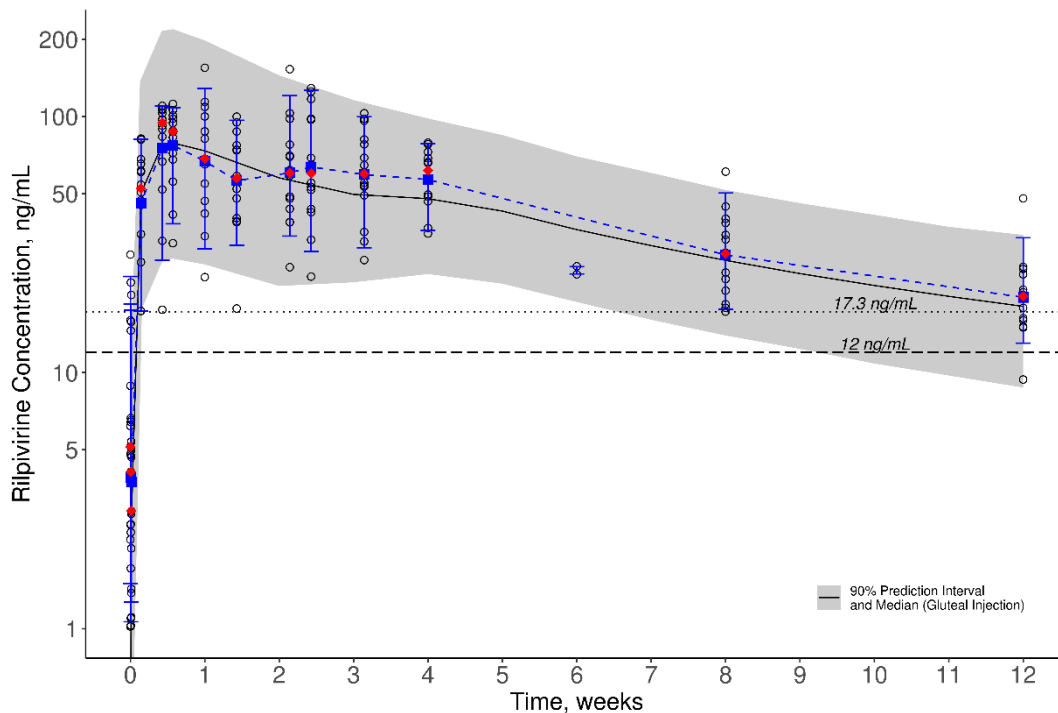

Note: the predictions are based on population PK model for IM gluteal injections  
 Open black circles: observed data thigh injection Phase 1 study; Blue dotted line (upper, lower vertical blue line), red closed circles: geometric mean (5<sup>th</sup>, 95<sup>th</sup> percentile), median of observed data thigh injection Phase 1 study  
 12 ng/mL: protein binding adjusted IC90  
 17.3 ng/mL: observed 5<sup>th</sup> percentile Ctau 4 weeks after first IM gluteal injection in ATLAS/FLAIR

**11.13.2. Sub-study Amendment rationale**

Data through week 12 from the Phase 1 study, as described above, suggest well tolerated thigh injections with CAB and RPV PK concentrations similar between thigh and gluteal injections. This study provides the evidence to evaluate thigh injections in HIV-infected individuals already receiving either Q4W or Q8W dosing of CAB/RPV LA. Instead of designing a separate study, A2M will be amended to allow an assessment of thigh injections as an alternative injection site than what is currently allowed in the prescribing

information to evaluate the PK parameters, safety, tolerability and virologic response in HIV-1 infected participants receiving CAB and RPV LA.

This sub-study will assess the comparability of CAB and RPV PK (and other parameters) following gluteal and thigh injections. Absorption of CAB following injection into an IM site is described as a first order process with an absorption rate constant,  $K_A$  LA. This absorption rate constant is the model parameter that is most sensitive to alterations in physiology and drug administration; the factors of gender, BMI and needle length all influence CAB absorption kinetics and are covariates for the parameter  $K_A$  LA. Plasma trough concentration ( $C_{tau}$ ) is the exposure parameter most associated with cabotegravir efficacy with an identified 5th percentile of population exposure used to determine efficacious regimens and interventions. Importantly, CAB has a wide therapeutic index where despite approximately 6-fold difference in CAB  $k_a$  values across the population (including a 2-fold mean difference between males and females) there is no difference in Phase 3 efficacy.

The main PK parameters of interest include  $C_{tau}$ , concentrations post dose [ $\sim C_{max}$ ], and AUC (0- $C_{tau}$ ). CAB and RPV PK parameter will be evaluated by comparing thigh injection with gluteal injection using the ratio of the geometric mean of thigh injection to the geometric mean of the gluteal injection for a PK parameter within each treatment arm (Q8W, Q4W) and each analyte (CAB, RPV). No formal statistical hypotheses are to be tested, and the sample size was selected mainly based on the precision of the geometric mean ratio estimate (thigh injection vs gluteal injection) and the data sufficiency to assess the safety parameters within 16 weeks of thigh injection phase.

Moreover, additional safety and tolerability data following thigh injections for both regimens will also be collected to better characterise the safety/tolerability profile of IM injections to the lateral thigh.

The study's main objective is to assess the comparability of PK between thigh vs gluteal injections in HIV-1 infected participants to support at home IM strategy for LA self-administration by demonstrating similar safety/tolerability and PK parameters between gluteal and thigh administration.

### 11.13.3. Sub-study Amendment: Objectives and Endpoints

Objectives	Endpoints
<b>Primary Endpoint</b>	
<b>Pharmacokinetic</b>	
To evaluate the PK of monthly and every two months dosing of CAB LA and RPV LA injections following intramuscular administration in the vastus lateralis (thigh) muscle (compared to gluteal injections) in HIV-1 infected participants currently	Plasma PK parameters for CAB LA and RPV LA ( $C_{tau}$ , concentrations post dose [ $\sim C_{max}$ ], and area under the curve [AUC (0- $\tau$ )]) for thigh injections during the thigh injection phase compared with similar PK parameters

Objectives	Endpoints
enrolled in the A2M sub-study	for gluteal injections.
<b>Secondary Endpoints</b>	
<b>Safety and tolerability</b>	
To assess safety and tolerability of monthly and every two months dosing of CAB LA and RPV LA following intramuscular injections in the vastus lateral (thigh) muscle in HIV-1 infected participants currently enrolled in the A2M sub-study.	<p>Incidence and severity of ISRs and AEs of special interest during the thigh injection phase.</p> <p>Proportion of participants who discontinue treatment due to ISRs and AEs of special interest during the thigh injection phase.</p>
<b>Virologic Efficacy</b>	
To assess the ability to maintain virologic suppression (HIV-RNA < 50 copies) in subjects who transition to thigh administrations of CAB and RPV after receiving at least 3 years of gluteal injections.	<ul style="list-style-type: none"> <li>• Proportion of participants with plasma HIV-1 RNA &lt;50 c/mL over time (including at Week 16) during the thigh injection phase using the FDA Snapshot algorithm.</li> <li>• Proportion of participants with plasma HIV-RNA ≥50 c/mL over time (including at Week 16) as per Food and Drug Administration (FDA) Snapshot algorithm during the thigh injection phase.</li> <li>• Proportion of participants with protocol-defined confirmed virologic failure (CVF) during the thigh injection phase.</li> </ul>
To assess viral resistance in participants experiencing protocol-defined confirmed virologic failure.	Incidence of treatment emergent genotypic and phenotypic resistance to CAB, RPV during the thigh injection phase.
<b>Health Outcomes</b>	
To assess patient reported outcomes during the thigh injection phase by administering the following health outcome measurements: Numerical Rating Scale (NRS) and HIVTSQ.	<ul style="list-style-type: none"> <li>• <b>Numerical Rating Scale (NRS):</b> To assess the tolerability of injections during both the Thigh and Gluteal Injection Phase</li> <li>• <b>HIVTSQ (both s and c versions):</b></li> </ul>

Objectives	Endpoints
	<p>To measure levels of satisfaction and detect change in satisfaction when switching from gluteal to thigh injections in total “treatment satisfaction” score, and individual item scores of the HIV Treatment Satisfaction Questionnaire (HIVTSQ) during the Thigh Injection Phase as well as the change from thigh during the Return to Gluteal Phase.</p>
<p>To assess participant’s preference of thigh injections during the thigh injection phase compared to gluteal injections.</p>	<p><b>Preference Questionnaire:</b> To assess patient’s preference, and reasons for preference, for injections received during the Thigh Injection Phase compared with prior gluteal injections as well as for injections received during the Return to Gluteal phase compared with prior thigh injections.</p>
<p><b>Exploratory Endpoints</b></p>	

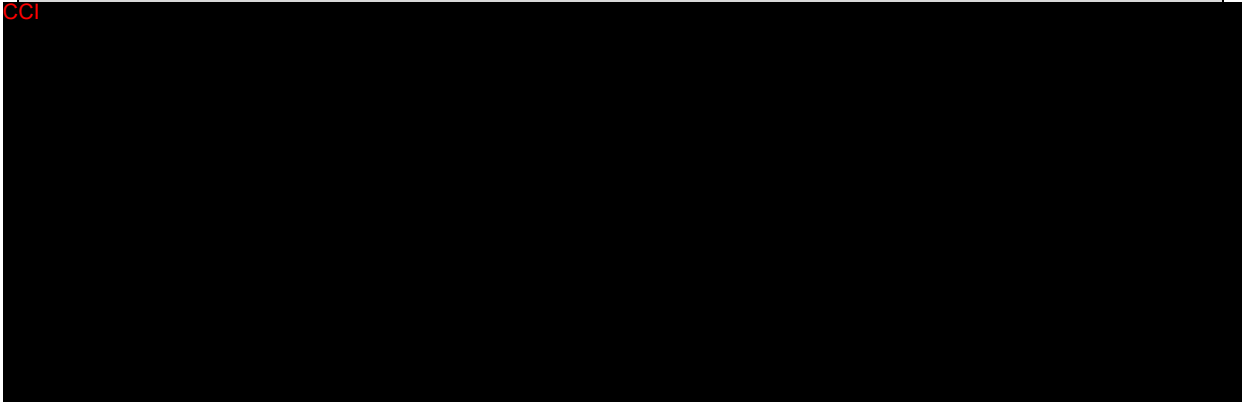

**11.13.4. Sub-study Amendment Design**

The A2M sub-study will consist of three phases including a Screening Phase (1 injection interval: 4 weeks for Q4W subjects and 8 weeks for Q8W subjects), a Thigh Injection Phase 16 weeks of thigh injections, 4 injection intervals for Q4W and 2 injection intervals for Q8W) and a Return to Gluteal Injection Phase (8 weeks of gluteal injections for both Q4W subjects and Q8W subjects). At the conclusion of the sub-study, participants will have the option to continue on the A2M main study or if commercial access treatment is available, the participant can transition off the sub-study and withdraw from A2M and proceed directly to CAB/RPV LA.

**Figure 21 Thigh Sub-study Amendment Design**

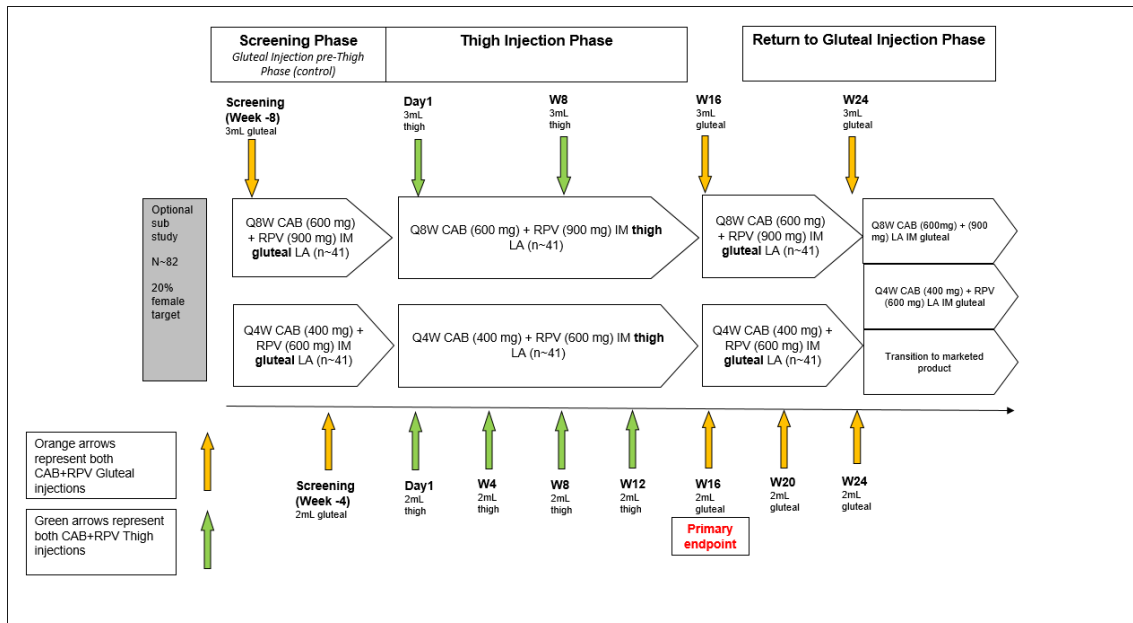

**NOTE:** All injection visits during the sub-study should kept to the same projected visit schedule as in the parent study.

**11.13.4.1. Sub-study Amendment: Inclusion and Exclusion Criteria**

**11.13.4.1.1. Sub-study Inclusion Criteria**

1. Capable of giving signed informed consent (Sub-study specific informed consent), which includes compliance with the requirements and restrictions listed in the consent form and in this protocol. Eligible participants or their legal guardians (and next of kin when locally required), must sign a written Informed Consent Form before any protocol-specified assessments are conducted. Enrolment of participants who are unable to provide direct informed consent is optional and will be based on local legal/regulatory requirements and site feasibility to conduct protocol procedures.
2. Eligible participants must have been on CAB LA + RPV LA regimen for a minimum of 152 weeks while on the ATLAS2-M study. Any disruptions in dosing during ATLAS2-M must be discussed with the Medical Monitor for a final determination of eligibility into the sub-study.
3. Plasma HIV-1 RNA <50 c/mL at Sub-Study Screening.

**11.13.4.1.2. Sub-study Exclusion Criteria**

4. More than 1 plasma HIV-1 RNA measurement  $\geq 50$  c/mL to <200 c/mL (virologic blip) within 24 weeks prior to sub-study Screening visit.

5. Any Suspected Virologic Failure (HIV-RNA>200 c/mL) as defined in Section [5.5.5.2](#) during ATLAS-2M study.
6. Subjects planning to require oral bridging during participation in the ATLAS-2M sub-study.
7. The participant has a tattoo or any dermatological condition overlying the thigh region which may interfere with interpretation of injection site reactions.
8. Any condition which, in the opinion of the Investigator, may interfere with the absorption, distribution, metabolism or excretion of the study drugs or render the participant unable to receive study medication.

Additionally, the following entry criteria detailed for the ATLAS-2M main study apply to the sub-study as well :

#### A2M parent study - Inclusion criteria

9. A female participant is eligible to participate if she is not pregnant (as confirmed by a negative serum human chorionic gonadotropin (hCG) test) not lactating, and at least one of the following conditions applies:
  - a. *Non-reproductive* potential defined as:
    - Pre-menopausal females with one of the following:
      - Documented tubal ligation
      - Documented hysteroscopic tubal occlusion procedure with follow-up confirmation of bilateral tubal occlusion
      - Hysterectomy
      - Documented Bilateral Oophorectomy
    - Postmenopausal defined as 12 months of spontaneous amenorrhea [in questionable cases a blood sample with simultaneous follicle stimulating hormone (FSH) and estradiol levels consistent with menopause (refer to laboratory reference ranges for confirmatory levels)]. Females on hormone replacement therapy (HRT) and whose menopausal status is in doubt will be required to use one of the highly effective contraception methods if they wish to continue their HRT during the study. Otherwise, they must discontinue HRT to allow confirmation of post-menopausal status prior to study enrolment.
  - b. **Reproductive potential** and agrees to follow one of the options listed in the Modified List of Highly Effective Methods for Avoiding Pregnancy in Females of Reproductive Potential (FRP) from 30 days prior to the first dose of study medication, throughout the study, for at least 30 days after discontinuation of all

oral study medications, and for at least 52 weeks after discontinuation of CAB LA and RPV LA.

The investigator is responsible for ensuring that participants understand how to properly use these methods of contraception.

#### **A2M parent study - Exclusionary medical conditions- for all participants**

10. Women who are pregnant, breastfeeding or plan to become pregnant or breastfeed during the study
11. Any evidence of a current Center for Disease Control and Prevention (CDC) Stage 3 disease [CDC, 2014] , except cutaneous Kaposi's sarcoma not requiring systemic therapy, and CD4+ counts <200 cells/ $\mu$ L are not exclusionary.
12. Participants with moderate to severe hepatic impairment.
13. Any pre-existing physical or mental condition (including substance use disorder) which, in the opinion of the Investigator, may interfere with the participant's ability to comply with the dosing schedule and/or protocol evaluations or which may compromise the safety of the participant.
14. Participants determined by the Investigator to have a high risk of seizures, including participants with an unstable or poorly controlled seizure disorder. A participant with a prior history of seizure may be considered for enrolment if the Investigator believes the risk of seizure recurrence is low. All cases of prior seizure history should be discussed with the Medical Monitor prior to enrolment.
15. Participants who, in the investigator's judgment, pose a significant suicide risk. Participant's recent history of suicidal behavior and/or suicidal ideation should be considered when evaluating for suicide risk.
16. Unstable liver disease (as defined by any of the following: presence of ascites, encephalopathy, coagulopathy, hypoalbuminemia, esophageal or gastric varices, or persistent jaundice or cirrhosis), known biliary abnormalities (with the exception of Gilbert's syndrome or asymptomatic gallstones or otherwise stable chronic liver disease per investigator assessment).
17. History of liver cirrhosis with or without hepatitis viral co-infection.
18. Ongoing or clinically relevant pancreatitis.
19. Clinically significant cardiovascular disease, as defined by history/evidence of congestive heart failure, symptomatic arrhythmia, angina/ischemia, coronary artery bypass grafting (CABG) surgery or percutaneous transluminal coronary angioplasty (PTCA) or any clinically significant cardiac disease.
20. Ongoing malignancy other than cutaneous Kaposi's sarcoma, basal cell carcinoma, or resected, non-invasive cutaneous squamous cell carcinoma, or cervical intraepithelial neoplasia; other localized malignancies require agreement between the investigator and the Study medical monitor for inclusion of the participant prior to randomization.
21. Any condition which, in the opinion of the Investigator, may interfere with the



<p>absorption, distribution, metabolism or excretion of the study drugs or render the participant unable to receive study medication.</p> <p>22. History or presence of allergy or intolerance to the study drugs or their components or drugs of their class. In addition, if heparin is used during PK sampling, participants with a history of sensitivity to heparin or heparin-induced thrombocytopenia must not be enrolled.</p> <p>23. Current or anticipated need for chronic anti-coagulation with the exception of the use of low dose acetylsalicylic acid (<math>\leq 325</math> mg) or hereditary coagulation and platelet disorders such as haemophilia or Von Willebrand Disease.</p>
<p><b>A2M parent study - Exclusionary Laboratory Values or Clinical Assessments at Screening (a single repeat to determine eligibility is allowed)</b></p>
<p>24. Any verified Grade 4 laboratory abnormality. A single repeat test is allowed during the Screening phase to verify a result.</p> <p>25. Any acute laboratory abnormality at Screening, which, in the opinion of the investigator, would preclude the participant's participation in the study of an investigational compound.</p> <p>26. Participant has estimated creatine clearance <math>&lt; 50</math> mL/min per <math>1.73\text{m}^2</math> via Chronic Kidney Disease-Epidemiology Collaboration (CKD-EPI) Method.</p> <p>27. Alanine aminotransferase (ALT) <math>\geq 3 \times</math> ULN at Screening.</p>

### A2M parent study - Concomitant Medications

28. Exposure to an experimental drug (with the exception of those in the ATLAS-2M study including CAB, CAB LA, and RPV, RPV LA) or experimental vaccine within either 30 days, 5 half-lives of the test agent, or twice the duration of the biological effect of the test agent, whichever is longer, prior to Day 1 of this study;
29. Treatment with any of the following agents within 28 days of Screening:
  - radiation therapy;
  - cytotoxic chemotherapeutic agents;
  - tuberculosis therapy with the exception of isoniazid (isonicotinylhydrazid, INH);
  - anti-coagulation agents;
  - Immunomodulators that alter immune responses such as chronic systemic corticosteroids, interleukins, or interferons. Note: Participants using short-term (e.g.  $\leq 21$  days) systemic corticosteroid treatment; topical, inhaled and intranasal corticosteroids are eligible for enrolment.
30. Treatment with an HIV-1 immunotherapeutic vaccine within 90 days of Screening.
31. Use of medications which are associated with Torsade de Pointes. (See SPM for a list of relevant medications).
32. Participants receiving any prohibited medication and who are unwilling or unable to switch to an alternate medication. Note: Any prohibited medications that decrease CAB or RPV concentrations should be discontinued for a minimum of four weeks or a minimum of three half-lives (whichever is longer) prior to the first dose and any other prohibited medications should be discontinued for a minimum of two weeks or a minimum of three half-lives (whichever is longer) prior to the first dose.

#### 11.13.4.2. Screening Phase (Gluteal IM)

Eligibility criteria must be assessed at the Screening visit and confirmed visit prior to the first Thigh injection. Participants who are enrolled in the sub-study and subsequently withdrawn from the main A2M study for any reason may not be re-screened. Screening procedures should occur within 35 days prior to Day 1 for Q4W subjects and 63 days prior to Day 1 for Q8W subjects of the first dose in the Thigh Injection Phase.

After the Screening visit, participants will need to return to the clinic 1 week later (for Q4W subjects) and 1 week and 4 weeks later (for Q8W subjects) to obtain PK sampling as outlined in the [Sub-study Time and Event Table](#).

#### 11.13.4.3. Thigh injections Phase (16 weeks)

**For participants receiving monthly (Q4W) IM injections while on A2M**

After confirming eligibility into the sub-study, participants will enter into the Thigh Injection Phase and receive an intramuscular injection of CAB LA (2 mL; 400 mg) on one lateral thigh and RPV LA (2 mL; 600 mg) into the opposite lateral thigh at the following visits ( $\pm 7$  days):

- Day 1
- Week 4
- Week 8
- Week 12

Participants will remain in the research unit for at least 2 hours after the injection for post-dose PK sampling and safety assessments.

After certain visits, participants will need to return to the clinic 1 week after the injection for PK sampling as outlined in Time and Event Table Section [11.13.5.1](#).

#### **For participants receiving 2M (Q8W) IM injections while on ATLAS 2M:**

After confirming eligibility into the sub-study, participants will enter into the Thigh Injection Phase and receive an intramuscular injection of CAB LA (3 mL; 600 mg) on one lateral thigh and RPV LA (3 mL; 900 mg) into the opposite lateral thigh at the following visits:

- Day 1
- Week 8

Participants will remain in the research unit for at least 2 hours after the injection for post-dose PK sampling and safety assessments.

Participants will then return to the clinic 1 week and 4 weeks after the injection for PK sampling as outlined in Time and Event Table Section [11.13.5.2](#).

#### **11.13.4.4. Return to Gluteal Injection Phase**

#### **For participants receiving monthly (Q4W) IM injections while on A2M**

Participants who received CAB LA + RPV LA IM thigh injection every 4 weeks for a total of 16 weeks during the Thigh Injection Phase will return to the clinic to receive an IM gluteal injection of CAB LA (2 mL; 400 mg) on one lateral thigh and RPV LA (2 mL; 600 mg) into the opposite lateral thigh at the following visits ( $\pm 7$  days):

- Week 16
- Week 20

Q4W participants will complete 8 weeks (2 injection cycles) of CAB/RPV LA and the Week 24 pre-injection assessments after which the participant's participation in the sub-study will conclude (at week 24). The Week 24 injection will be the first injection back on the main study (A2M).

The 2 injection cycles for Q4W dosing during the Gluteal Injection Phase will correspond to 1 injection cycle during the Gluteal Injection Phase for the Q8W dosing participants thereby ensuring similar assessments for both arms (see T&E).

**For participants receiving 2M (Q8W) IM injections while on A2M:**

Participants, who received CAB LA + RPV LA IM thigh injection every 8 weeks for a total of 16 weeks during the Thigh Injection Phase will return to the clinic to receive an IM gluteal injection of CAB LA (3 mL; 600 mg) on one lateral thigh and RPV LA (3 mL; 900 mg) into the opposite lateral thigh at the following visits:

- Week 16
- Week 24

Q8W participants will complete 8 weeks (1 injection cycle) of CAB/RPV LA and the Week 24 pre-injection assessments after which the participant's participation in the sub-study will conclude (at Week 24). The W24 injection will be the first injection back on the parent study (A2M).

The 1 injection cycle for Q8W dosing during the Gluteal Injection Phase will correspond to 2 injection cycles during the Gluteal Injection Phase for the Q4W dosing participants thereby ensuring similar assessments for both arms (see T&E)

**11.13.4.5. Sub-study completion**

Participants are considered to have completed the study if they complete pre-dose assessments at sub-study Week 24 visit.

Depending on the local availability of the marketed product in each country, after the sub-study is completed participants will be invited to:

- Countries where CAB LA+RPV LA marketed product is not yet locally available: Continue in the Extension phase of the main study and complete study visits as per Time & Events table in Section [7.1](#)).
- Countries where CAB LA+RPV LA marketed product is locally available: Transition to CAB LA + RPV LA marketed product or an alternative ART as indicated below:
  - i. After the pre-injection assessments are completed at week 24, the participant **will receive the last gluteal injection as part of the main study.**
  - ii. **Participant will complete Safety Follow Up visit** 2-4 weeks after the last injection (please refer to Section [5.6](#) of the Protocol) before transitioning to a marketed ART.

Note: If the participant has to withdraw from the study due to safety related reasons once CAB LA + RPV LA marketed product is locally available (see Section 5.5) the subject would need to complete withdrawal visit and enter in the Long Term Follow Up phase (see Section 4.2.4).

#### 11.13.4.6. Sub-study Amendment Withdrawal/Stopping Criteria

Participants meeting **Withdrawal/Stopping criteria as per Section 5.5** will discontinue the study treatment and be withdrawn from both A2M and the sub-study, and will complete assessments per T&E table in Section 7.1 and enter in the Long Term Follow-Up phase.

Participants who decide to discontinue their participation in the sub-study **for non-safety reasons** (refer to Section 5.5), including participants who require **Oral Bridging** during the sub-study **or** participants who decide to discontinue their participation in the sub-study due to **injection-site (thigh) related tolerability reasons**:

- In countries where the marketed products of CAB and RPV LA are **not yet locally available**, such patients will be allowed to transition back to the main study and continue with IM gluteal injections per the randomized dosing schedule.
- In countries where the marketed products of CAB and RPV LA are **locally available**: patients will be invited to return to gluteal injections in the main study and receive 1 more gluteal injections (additional injections might be required if requested by MM) before transitioning to marketed product as described in Section 4.2.4 and Section 5.6

##### 11.13.4.6.1. Sub-study Amendment Specific Virologic Failure Guidance

Refer to Section 5.5.3, Section 5.5.4 and Section 5.5.5

##### 11.13.4.6.2. Sub-study Amendment HIV-1 RNA Blips Guidance

Refer to Section 5.5.5.1

Participants who have a HIV-1 RNA  $\geq 50$  c/mL and  $< 200$  c/mL at any timepoint during the sub-study including during the Return to Gluteal Injection Phase, must return to the clinic as soon as possible (no later than 4 weeks) for a repeat HIV-1 RNA test.

In case of a virologic blip occurring at the last study visit of the sub-study (Return to Gluteal Injection Phase), the Medical Monitor should be immediately consulted for further guidance.

##### 11.13.4.6.3. Sub-study Amendment Specific Withdrawal Criteria - Pregnancy

If a subject becomes pregnant during the substudy, the subject would need to withdraw from the substudy and have the option to continue with gluteal injections in the main A2M study after signing a pregnancy-specific ICF addendum or be withdrawn from A2M. Please refer to [Appendix 11](#) for additional information.

**11.13.5. Sub-study: Time and Events table**

**11.13.5.1. Sub-study: Time and Events Table for CAB LA + RPV LA Q4 Weekly Administration**

Procedure	Screening Phase <sup>d</sup> <u>Gluteal administration</u>		Thigh Injection Phase <sup>d</sup> Q4 Weekly <u>thigh administration</u>						Return to Gluteal Injection Phase <sup>d</sup> Q4 Weekly <u>gluteal admin.</u>			
	Screening (Week -4)	Week -3	Day1	Week 1	Week 4	Week 8	Week 12	Week 13	Week 16	Week 17	Week 20	Week 24
IM treatment administration <sup>i</sup>	X		X		X	X	X		X		X	
Written Inform consent	X											
Eligibility Verification (Inclusion/Exclusion criteria)	X											
Symptom directed physical exam and Medical assessment <sup>a</sup>	X		X		X	X	X		X		X	X
Weight and BMI			X						X			

Procedure	Screening Phase <sup>d</sup> <u>Gluteal administration</u>		Thigh Injection Phase <sup>d</sup> Q4 Weekly <u>thigh administration</u>						Return to Gluteal Injection Phase <sup>d</sup> Q4 Weekly <u>gluteal admin.</u>			
	Screening (Week -4)	Week -3	Day1	Week 1	Week 4	Week 8	Week 12	Week 13	Week 16	Week 17	Week 20	Week 24
Vital Signs, BP, HR, temp <sup>b</sup>	X		X						X			
Smoking status	X											
12-lead ECG <sup>c</sup>	X		X						X			
HIV associated conditions	X	X	X	X	X	X	X	X	X	X	X	X
AEs, SAEs, concomitant medications	X	X	X	X	X	X	X	X	X	X	X	X
ISR assessments for IM injections	X	X	X	X	X	X	X	X	X	X	X	X
Clinical Chemistry and Hematology	X		X		X	X	X		X			X
Pregnancy Testing, SERUM <sup>c</sup>	S		S		S	S	S		S		U	S

Procedure	Screening Phase <sup>d</sup> <u>Gluteal administration</u>		Thigh Injection Phase <sup>d</sup> Q4 Weekly <u>thigh administration</u>						Return to Gluteal Injection Phase <sup>d</sup> Q4 Weekly <u>gluteal admin.</u>			
	Screening (Week -4)	Week -3	Day1	Week 1	Week 4	Week 8	Week 12	Week 13	Week 16	Week 17	Week 20	Week 24
HIV-1 RNA and sample for storage (S)	X		X		X	X	X		X			X
CD4+ cell count	X		X		X	X	X		X			X
CD8+ cell count			X						X			
Urinalysis <sup>f</sup>			X						X			
Fasting lab assessments: Glucose, Cholesterol (Total, HDL and LDL) and triglycerides <sup>g</sup>			X						X			
PBMC for storage			X									



Procedure	Screening Phase <sup>d</sup> <u>Gluteal administration</u>		Thigh Injection Phase <sup>d</sup> Q4 Weekly <u>thigh administration</u>						Return to Gluteal Injection Phase <sup>d</sup> Q4 Weekly <u>gluteal admin.</u>			
	Screening (Week -4)	Week -3	Day1	Week 1	Week 4	Week 8	Week 12	Week 13	Week 16	Week 17	Week 20	Week 24
PK sample collection <sup>j</sup>												
Pre dose PK sampling	X		X		X	X	X		X			
<u>2h</u> Post dose PK sampling			X		X	X	X					
Post dose PK sampling (~Cmax)		X		X				X		X		
PROs <sup>l</sup>												
<u>HIVTSQc</u>									X <sup>k</sup>			
<u>HIVTSQs</u>			X						X <sup>k</sup>		X	
<u>NRS<sup>h</sup></u>	X	X	X	X			X	X	X	X		
<u>Preference Thigh inj. vs Gluteal inj.</u>							X				X	

**Sub-study Footnotes:**

- a. Physical exams should be conducted as part of normal routine clinical care. Medical assessments include any decisions the study staff must make for participants management and/or care of participant.
- b. Measure vital signs after about 5 minutes of rest in a semi-supine position.
- c. A 12-lead ECG will be performed after resting in a semi-supine position for at least 5 minutes. ECGs will be performed pre-dose. A 2-hour post dose ECG will also be performed at sub-study Day1 visit.
- d. All injection visits during the sub-study should kept to the same projected visit schedule as in the parent study.
- e. Women of childbearing potential only. SR=serum, UR=urine. Urine pregnancy test can be performed at study visits when other blood draws are not required in order to limit needle sticks.
- f. A morning specimen is preferred.
- g. An overnight fast is preferred; however, a minimum of a 6-hour fast is acceptable.
- h. Should be collected 30 to 60 minutes post injection
- i. Week 24 IM administration will not be considered part of the sub-study assessments. The IM administration at W24 and any assessments completed after IM administration at this visit will be considered part of the parent study.
- j. PK window allowed for sample collection: For 1-week post dose sample (3 to 10 days post dose), for 4-week post dose sample (+7 days) and for 2-hours post dose samples ( $\pm 1$  hour)
- k. At Week 16, HIVTSQs should be administered before HIVTSQc.
- l. All Patient Report Questionnaires/Surveys - except NRS - will be administered via paper instrument (in exceptional circumstances the questionnaires could be completed via telephonic interview, please refer to COVID19 appendix for additional details) at the beginning of the visit before any other assessments are conducted.

**11.13.5.2. Sub-study: Time and Events Table for CAB LA + RPV LA Q8 Weekly Administration**

Procedure	Screening Phase <sup>d</sup> <u>Gluteal administration</u>			Thigh injection phase <sup>d</sup> <u>Q8 Weekly thigh administration</u>						Return to Gluteal Injection Phase <sup>d</sup> <u>Q8 Weekly gluteal admin.</u>		
	Screening (Week -8)	Week -7	Week -4	Day1	Week 1	Week 4	Week 8	Week 9	Week 12	Week 16	Week 17	Week 24
IM treatment administration <sup>i</sup>	X			X			X			X		
Written Inform consent	X											
Eligibility Verification (Inclusion/Exclusion criteria)	X											
Symptom directed physical exam and Medical assessment <sup>a</sup>	X			X			X			X		X
Weight and BMI	X									X		
Vital Signs, BP, HR, temp <sup>b</sup>	X			X						X		
Smoking status	X											
12-lead ECG <sup>c</sup>	X			X						X		
HIV associated	X	X	X	X	X	X	X	X	X	X	X	X

Procedure	Screening Phase <sup>d</sup> <u>Gluteal administration</u>			Thigh injection phase <sup>d</sup> <u>Q8 Weekly thigh administration</u>						Return to Gluteal Injection Phase <sup>d</sup> <u>Q8 Weekly gluteal admin.</u>		
	Screening (Week -8)	Week -7	Week -4	Day1	Week 1	Week 4	Week 8	Week 9	Week 12	Week 16	Week 17	Week 24
conditions												
AEs, SAEs, concomitant medications	X	X	X	X	X	X	X	X	X	X	X	X
ISR assessments for IM injections	X	X	X	X	X	X	X	X	X	X	X	X
Clinical Chemistry and Hematology	X			X			X			X		X
Pregnancy Testing, SERUM <sup>e</sup>	S			S			S			S		S
HIV-1 RNA and sample for storage (S)	X			X		X	X		X	X		X
CD4+ cell count	X			X			X			X		X
CD8+ cell count	X			X						X		
Urinalysis <sup>f</sup>	X			X						X		
Fasting lab assessments: Glucose, Cholesterol (Total, HDL and LDL) and	X			X						X		

Procedure	Screening Phase <sup>d</sup> <u>Gluteal administration</u>			Thigh injection phase <sup>d</sup> Q8 Weekly <u>thigh administration</u>						Return to Gluteal Injection Phase <sup>d</sup> Q8 Weekly <u>gluteal admin.</u>		
	Screening (Week -8)	Week -7	Week -4	Day1	Week 1	Week 4	Week 8	Week 9	Week 12	Week 16	Week 17	Week 24
triglycerides <sup>g</sup>												
PBMC for storage				X								
PK samples <sup>j</sup>												
Pre dose PK sampling	X			X			X			X		
<u>2h</u> Post dose PK sampling				X			X					
Post dose PK sampling (~Cmax)		X	X		X	X		X	X		X	
PROs <sup>l</sup>												
<u>HIVTSQc</u>										X <sup>k</sup>		
<u>HIVTSQs</u>				X						X <sup>k</sup>		X
<u>NRS<sup>h</sup></u>	X	X		X	X		X	X		X	X	
<u>Preference Thigh inj. vs Gluteal inj.</u>							X					X

**Sub-study Footnotes:**

- a. Physical exams should be conducted as part of normal routine clinical care. Medical assessments include any decisions the study staff must make for participants management and/or care of participant.
- b. Measure vital signs after about 5 minutes of rest in a semi-supine position.
- c. A 12-lead ECG will be performed after resting in a semi-supine position for at least 5 minutes. ECGs will be performed pre-dose. A 2-hour post dose ECG will also be performed at sub-study Day1 visit.
- d. All injection visits during the sub-study should kept to the same projected visit schedule as in the parent study.
- e. Women of childbearing potential only. SR=serum, UR=urine. Urine pregnancy test can be performed at study visits when other blood draws are not required in order to limit needle sticks.
- f. A morning specimen is preferred.
- g. An overnight fast is preferred; however, a minimum of a 6-hour fast is acceptable.
- h. Should be collected 30 to 60 minutes post injection
- i. Week 24 IM administration will not be considered part of the sub-study assessments. The IM administration at W24 and any assessments completed after IM administration at this visit will be considered part of the parent study.
- j. PK window allowed for sample collection: For 1-week post dose sample (3 to 10 days post dose), for 4-week post dose sample (+7 days) and for 2-hours post dose samples ( $\pm 1$  hour)
- k. At Week 16, HIVTSQs should be administered before HIVTSQc.
- l. All Patient Report Questionnaires/Surveys - except NRS - will be administered via paper instrument (in exceptional circumstances the questionnaires could be completed via telephonic interview, please refer to COVID19 appendix for additional details) at the beginning of the visit before any other assessments are conducted.

### **11.13.5.3. Sub-study: Value Evidence and Outcomes**

Health outcomes assessments will be conducted according to the Time and Events Table (Section [11.13.5](#)). Assessments are recommended to be administered with a paper instrument at the beginning of the visit (except for NRS which is performed after the injections) prior to collection of blood for analysis and other scheduled assessments.

There will be four health outcome measurements that will be administered during the sub-study including Numerical Rating Scale (NRS), HIVTSQc, HIVTSQs and a Preference questionnaire.

#### **Numerical Rating Scale (NRS)**

A numeric rating scale was used to assess the level of pain experienced following injections with CAB + RPV. The scale contains one item and the response scale is ranging from 0= “no pain” to 10= “extreme pain”. The NRS was used to assess maximum level of pain on the day of the injection as well as maximum level of pain one week following injection. NRS questionnaires should be collected 30 to 60 minutes post injection.

#### **HIV Treatment Satisfaction Questionnaire (HIVTSQ)**

HIVTSQ is a self-completion measure specifically designed to measure treatment satisfaction in PLHIV. It explores multiple aspects of treatment satisfaction including side effects, treatment demands, convenience, flexibility and understanding of HIV.

There are two versions of this questionnaire: HIVTSQs and HIVTSQc.

HIVTSQs (status version) is needed to measure absolute level of satisfaction while the HIVTSQ change version (HIVTSQc) was developed to overcome ceiling effects associated with HIVTSQs and enhance sensitivity to change by allowing those who were optimally (or close to optimally) satisfied at baseline to express even greater satisfaction at follow up. The HIVTSQc is assessing the change in patients’ satisfaction between their previous and their current treatment within the same group.

Total score for HIVTSQs ranges from 0-66 and. Higher scores indicate a greater satisfaction and a lower score indicate dissatisfaction. Individual score range from 0-6.

HIVTSQc total score ranges from -33 to 33. A higher score indicate improvement in satisfaction with treatment; lower scores indicate a greater deterioration in satisfaction with treatment; a score of 0 represents no change. Individual items scores range from -3 to 3 (-3= much less satisfied now, 3= much more satisfied now).

#### **Preference Questionnaire**

A preference question was used to assess patients’ preference, and reasons for preference, for the thigh injections compared with the gluteal injections. The “Preference” questionnaire will include a single item questions evaluating preference of HIV treatment and the attributes supporting this preference.

**11.13.5.4. Sub-study: Pharmacokinetics sample collection****Table 14 Sub-study CAB and RPV Plasma Pharmacokinetic Sample Schedule**

Group	Analytes	Sample Times Relative to Dose
Participants receiving CAB LA + RPV LA <b>Q4W</b> injections	CAB and RPV	<u>Pre-Dose:</u> Screening (Week -4), Day 1, Week 4, Week 8, Week 12, Week 16 <u>2 hours Post dose:</u> Day 1, Week 4, Week 8, Week 12 <u>1 Week Post dose:</u> Week -3, Week 1, Week 13
Participants receiving CAB LA + RPV LA <b>Q8W</b> injections	CAB and RPV	<u>Pre-Dose:</u> Screening (Week -8), Day 1, Week 8, Week 16 <u>2 hours Post dose:</u> Day 1, Week 8 <u>1 Week Post dose:</u> Week -7, Week 1, Week 9 <u>4 Week Post dose:</u> Week -4, Week 4, Week 12

**PK window collection:** All scheduled PK samples should be collected on the Day of the corresponding visit. Pre-dose samples will be taken prior to performing dosing within the clinic.

Additional details concerning handling of PK samples, labeling and shipping directions will be supplied in the central laboratory manual.

**11.13.6. Sub-study Amendment: Study Treatment****11.13.6.1. Sub-study Amendment: Investigational Product and Other Study treatment**

Please refer to Sections [6.1.1.3](#) Cabotegravir Injectable Suspension (CAB LA) and Section [6.1.1.4](#) Rilpivirine Injectable Suspension (RPV LA) of main A2M protocol.

**11.13.6.2. Sub-study Dosage and Administration**

**NOTE:** All injection visits during the sub-study should kept to the same projected visit schedule as in the parent study.

**Participants receiving monthly (Q4W) IM injections** while on A2M study who enter into the Thigh Injection Phase will receive an intramuscular injection of CAB LA (2 mL; 400 mg) on one lateral thigh and RPV LA (2 mL; 600 mg) into the opposite lateral thigh on Day 1 of the Thigh Injection Phase. Subsequent thigh injections with CAB LA 400 mg and RPV LA 600 mg will occur every 4 weeks ( $\pm 7$  days).



Participants who received CAB LA + RPV LA IM thigh injection every 4 weeks for a total of 16 weeks during the Thigh Injection Phase will return to the clinic 4 weeks later ( $\pm 7$  days) to receive their first IM gluteal injection (at Week 16) of CAB LA (2mL; 400mg) and RPV LA (2 mL; 600 mg) during the Return to Gluteal Injection Phase. The subsequent gluteal injection with CAB LA 400 mg and RPV LA 600 mg will occur 4 weeks later ( $\pm 7$  days) at Week 20. Gluteal injection administered at Week 24 visit will be considered part of the parent study.

The interval between injection visits will be limited to a maximum of 5 weeks. The Medical Monitor must be contacted to discuss individual participant case management if the length of time between injections exceeds or is projected to exceed 5 weeks.

**Participants receiving 2M (Q8W)** IM injections while on A2M study who enter into the Thigh Injection Phase will receive an intramuscular injection of CAB LA (3 mL; 600 mg) on one lateral thigh and RPV LA (3 mL; 900 mg) into the opposite lateral thigh on day 1 of the Thigh Injection Phase. Subsequent thigh injections with CAB LA 600 mg and RPV LA 900 mg will occur every 8 weeks ( $\pm 7$  days).

Participants who received CAB LA + RPV LA IM thigh injection every 8 weeks for a total of 16 weeks during the Thigh Injection Phase will return to the clinic 8 weeks later (at Week 16) to receive their first IM gluteal injection of CAB LA (3mL; 600mg) and RPV LA (3 mL; 900 mg) during the Return to Gluteal Injection phase. The subsequent gluteal injection with CAB LA 600 mg and RPV LA 900 mg will 8 weeks later ( $\pm 7$  days) at Week 24. Gluteal injection administered at Week 24 visit will be considered part of the parent study.

The interval between injection visits will be limited to a maximum of 9 weeks. The Medical Monitor must be contacted to discuss individual participant case management if the length of time between injections exceeds or is projected to exceed 9 weeks.

For additional details regarding the Sub-study dosage and administration please refer to the Study Reference Manual.

#### **11.13.6.3. Oral Bridging during the Sub-study**

Given the limited number of thigh injections for both Q4W (4 injections) and Q8W (2 injections) during the sub-study, any oral bridging will not be allowed in this sub-study.

#### **11.13.7. Sub-study Data Management**

Please refer to Section 8.

#### **11.13.8. Sub-study Statistical Considerations and Data Analyses**

##### **11.13.8.1. Statistical Hypotheses**

The primary objective of this sub-study is to evaluate the pharmacokinetics of monthly and every 2 months dosing of CAB LA and RPV LA injections following intramuscular administration in the vastus lateralis (thigh) muscle of HIV-1 infected participants

currently enrolled in the A2M study. No formal statistical hypotheses are to be tested. Where appropriate, an estimation approach will be taken and point estimates and confidence intervals will be constructed for the ratio of the geometric mean of thigh injection to the geometric mean of the gluteal injection.

#### **11.13.8.2. Sample Size Considerations**

No formal sample size calculation has been made. The sample size of 41 subjects per treatment arm (Q8W, Q4W) is sufficient to evaluate the geometric mean ratio (thigh injection vs gluteal injection) of PK parameters and to assess the safety parameters within 16 weeks of the thigh injection phase.

PK parameter comparisons of interest are shown in [Table 15](#). Each comparison (first or last thigh injection vs gluteal injection) will be evaluated separately by treatment arm and analyte (CAB, RPV). In the main study, the observed between subject coefficient of variation (CV<sub>b</sub>) for Week 96 trough PK concentrations among overall population ranges from 40% to 56%. Conservatively, assuming within subject coefficient of variation is 56%, it is estimated that the half width of the 90% confidence interval for the geometric mean ratios on log-scale will be within 19%. If the point estimate of the ratio of geometric means is 1, then the 90% confidence interval will be approximately (0.83, 1.21) on the original scale.

**Table 15** Planned Pharmacokinetic Parameter Comparisons between Thigh and Gluteal Injections

Parameters (CAB and RPV)	Q8W	Q4W
$C_{max}$ , $C_{tau}$ (end of dosing interval <sup>a</sup> ), AUC(0-tau)	Thigh Injection 1: Gluteal Injection	Thigh Injection 1: Gluteal Injection
	Thigh Injection 2: Gluteal Injection	Thigh Injection 4: Gluteal Injection

<sup>a</sup>Dosing interval is defined in Table 16.

**Table 16** Dosing Intervals for Each Treatment Arm

Treatment Arm	Dosing Interval		
	Gluteal Injection	First Thigh Injection	Last Thigh Injection
Q8W	Week -8 to Day 1	Day 1 to Week 8	Week 8 to Week 16
Q4W	Week -4 to Day 1	Day 1 to Week 4	Week 12 to Week 16

Table 17 provides probabilities of observing at least one subject with an adverse event (AE) at a given true AE rate across a range of sample sizes. The smaller true AE rate, the larger sample size is required to observe the AE with a decent probability. In the main study, the observed rates for injection site reaction (ISR) AEs and AEs of special interest (AESI) during the Maintenance phase varies, ranging from 0% to 79%. At true AE rate of 0.5%, the sample size of 41 subjects per treatment arm can provide approximately 18% probability of observing at least one subject with AE in each treatment arm. In case of rare events (e.g. serious AEs) with 0% observed rate, the upper limit of the 1-sided 95% clopper-pearson confidence interval is 7.0% with the sample size of 41 subjects.

**Table 17** Probability of Observing at Least One Subject with AE at a Given True AE Rate

True AE Rate (%)	Probability of Observing at Least One Subject with AE in N Subjects (%)				
	N=10	N=20	N=30	N=40	N=50
0.5	4.9	9.5	14.0	18.2	22.2
1	9.6	18.2	26.0	33.1	39.5
2.5	22.4	39.7	53.2	63.7	71.8
10	65.1	87.8	95.8	98.5	99.5
25	94.4	99.7	100.0	100.0	100.0
50	99.9	100.0	100.0	100.0	100.0
80	100.0	100.0	100.0	100.0	100.0

### **11.13.8.3. Data Analysis Considerations**

#### **11.13.8.3.1. Analysis Populations**

##### **Pharmacokinetic Concentration Population for Thigh PK Sub-study Amendment**

The pharmacokinetic concentration population for this sub-study will consist of all participants who received at least one CAB and/or RPV thigh injection and provide at least one non-missing CAB and/or RPV plasma concentration value (non-quantifiable values will be considered as non-missing values) during the sub-study.

##### **Pharmacokinetic Parameter Population for Thigh PK Sub-study Amendment**

The pharmacokinetic parameter population for this sub-study will consist of all participants who received at least one CAB and/or RPV thigh injection and had at least one available PK parameter estimate.

##### **Intent-to-Treat Exposed Population for Thigh PK Sub-study Amendment**

The ITT-E population for this substudy will consist of all participants who were randomized in the main study and received at least one CAB and/or RPV thigh injection. Participants will be assessed according to their randomized treatment, regardless of the treatment they received. Participants in this population will be included in the efficacy and health outcomes analyses.

##### **Safety Population for Thigh PK Sub-study Amendment**

The safety population for this sub-study will consist of all participants who were randomized in the main study and received at least one CAB and/or RPV thigh injection. Participants will be assessed according to the actual treatment they received.

Additional populations may be added and details will be provided in the RAP.

#### **11.13.8.3.2. Planned Analyses**

Only one final analysis is planned after all subjects have completed the sub-study.

### **11.13.8.4. Key Elements of Analysis Plan**

#### **11.13.8.4.1. Primary Analysis**

The primary analysis is to compare the thigh injection with the gluteal injection using the ratio of the geometric mean of thigh injection to the geometric mean of the gluteal injection for a PK parameter within each treatment arm (Q8W, Q4W) and each analyte (CAB, RPV). The PK parameter comparisons of interest are described in [Table 15](#) of Section [11.13.8.2](#). No formal hypothesis testings will be performed.

Following loge-transformation,  $C_{max}$ ,  $C_{tau}$  and  $AUC(0-tau)$  will be separately analyzed by treatment arm and analyte using a mixed effects model with fixed effect term for type of injection (thigh, gluteal) and random effect term for subject. In each model, only subjects

with PK parameter estimates from corresponding both thigh and gluteal injections are included. For example, in the model for comparing  $C_{max}$  between the first CAB thigh injection vs gluteal CAB injection for Q8W subjects, only Q8W subjects with  $C_{max}$  estimates from both first CAB thigh injection and CAB gluteal injection are included. Point estimates and their associated 90% confidence intervals will be constructed for the differences between the thigh injection and the gluteal injection. The point estimates and their associated 90% confidence intervals from the log-transformed analysis will then be back-transformed to provide point estimates and 90% confidence intervals for the ratios between the thigh injection and the gluteal injection on the original scale.

#### **11.13.8.4.2. Secondary and Exploratory Analyses**

The proportion of participants with HIV-1 RNA  $\geq 50$  c/mL and HIV-1 RNA  $< 50$  c/mL during the thigh injection phase will be summarized using FDA Snapshot algorithm for the ITT-E population for the substudy. Proportion of participants with protocol-defined confirmed virologic failures will also be summarized over time.

The proportion of participants reporting AEs will be tabulated for each treatment group. The following summaries of AEs will be provided:

- Incidence and severity of all AEs
- Incidence and severity of treatment related AEs
- Incidence and severity of AEs leading to withdrawal
- Incidence of SAEs
- ISR AEs from study drug injections at the event level and subject level, separately.
- Change from baseline (latest non-missing value prior to the first thigh injection) in laboratory will be summarized by visit and treatment group.
- The incidence of observed genotypic and phenotypic resistance to NRTIs and INIs, PIs, and NNRTIs will be summarized by treatment arm for subjects meeting confirmed virologic failure criteria.

The health outcomes analyses include analyses of data collected from the following four questionnaires, HIVTSQ (both s and c versions), NRS and Preference between thigh and gluteal injections. Further details will be provided in the RAP.

#### **11.13.9. Sub-study Amendment Pharmacokinetics**

Pharmacokinetic analysis will be the responsibility of the Clinical Pharmacology

Modeling & Simulation Department (CPMS), GSK. Individual Plasma CAB and RPV concentration-time data will be analyzed by non-compartmental methods with WinNonlin 5.2 or higher. Calculations will be based on the actual sampling times recorded during the study. PK intervals are defined for each arm of the substudy in [Table 16](#), and the concentration at the end of the interval will also serve as the predose concentration for the subsequent interval. The following pharmacokinetic parameters will be determined for each interval, as data permit: maximum concentration ( $C_{max}$ ), time to  $C_{max}$  ( $t_{max}$ ), area under the plasma concentration-time curve through the end of the dosing interval ( $AUC(0-\square)$ ), and concentration at the end of the dosing interval ( $C_{\square}$ ).

Plasma concentration data will be summarized descriptively by analyte and treatment regimen and presented in graphical and/or tabular form. Parameters will be summarized by analyte and treatment regimen.  $C_{max}$ ,  $AUC(0-\square)$  and  $C_{\square}$  treatment comparisons are described above (see [Table 15](#));  $t_{max}$  will not be compared statistically. All pharmacokinetic data (both CAB and RPV) will be stored in the Archives, GlaxoSmithKline Pharmaceuticals, R&D. Additional analyses including modelling, simulation and external validation may be performed to assist in the clinical interpretation of these data and will be reported separately.

## 11.14. Appendix 14: Protocol Amendment History

The Protocol Amendment Summary of Changes Table for the current amendment is located directly before the Table of Contents (TOC).

### Amendment 5 16-Apr-2021

#### Overall Rationale for Amendment 5

The primary purposes of this amendment are:

- To allow participants who become pregnant to remain in the study and not be withdrawn due to pregnancy. Allowing pregnant participants to continue in the study will negate any additional and subsequent fetal exposures to new antiretrovirals agents that would occur if the pregnant participant was withdrawn from the study and placed on an oral SOC regimen. An Appendix, “Information and Guidance for Managing Pregnant Participants” was inserted as Appendix 11, and all subsequent appendices were renumbered accordingly.
- Contraceptive methods have been updated to permit the use of progestogen-only implantable and injectable contraceptives without the requirement of a second highly effective method.
- Removal of the optional collection of cord blood and/or breast milk after delivery.
- Removal of the option for study treatment rechallenge following suspected drug-induced liver injury (DILI)
- Clarification of which participants enter the LTFU phase when CAB+RPV LA marketed product is locally available.
- Clarification added: The Reason for Oral Bridging and Preference questionnaire will also be administered at Withdrawal if it occurred at or before Week 152 only to participants who received oral bridging during the Maintenance and/or Extension Phases.
- Medical Device reporting requirement added
- Co-enrolment (Only applicable for South African participants)
- Clinical and safety references updated
- Removal of the reference to “randomized study treatment” in Overall design sections for alignment with CAB program studies and transition to marketed product plan.

Other additional edits were made, for clarity and/or correction.

Section # and Name	Description of Change	Brief Rationale
Section 1.3 Overall Design	New text added to clarify the Long Term Follow up phase requirements depending on the local availability of marketed product and the reason for stopping the study treatment.	Transition to marketed product
Section 1.4.3 Extension Phase		
Section 1.4.4. Long Term Follow- Up Phase		

Section # and Name	Description of Change	Brief Rationale
<p>Section 4.2.3 Extension phase</p> <p>Section 4.2.4 LTFU Phase- IM Regimen Only</p> <p>Section 5.5. Withdrawal/Stopping Criteria</p>		
<p>Section 2, Section 4 and Section 7</p>	<p>Safety update text added throughout the following sections:</p> <ul style="list-style-type: none"> <li>• Section 2.3.1, Drug Induced Liver Injury (DILI), updated text "All participants with suspected DILI identified in clinical studies to date were receiving oral cabotegravir "</li> <li>• Section 2.3.1 Risk Assessment RPV LA, Risk of treatment failures updated text: "Both IM CAB and RPV have demonstrated antiviral activity in large clinical studies and the two drug combination dosed Q4W has demonstrated sustained antiviral activity in studies 200056, 201584 and 201585 however the efficacy of Q8W dosing remains under evaluation."</li> <li>• Section 2.3.1.1 Other Clinically Relevant Information, Adverse Events of Special Interest, Seizure, updated text: "Several cases of seizure have occurred during the cabotegravir program. These cases have had alternative explanations for their occurrence (...) Several cases of seizure have occurred during the cabotegravir program. These cases have had alternative explanations for their occurrence (...) Report any cases of seizure or seizure like events immediately."</li> <li>• Section 2.3.2 Benefit Assessment, updated text "The antiviral activity against HIV-1 of CAB has been well established through Phase 2 and Phase 3"</li> <li>• Section 4.4 Scientific Rationale for Study Design, updated text "The CAB LA + RPV LA Q4W regimen is currently under evaluation in the ongoing Phase 3 201584 and 201585 studies"</li> <li>• Section 4.5.1 Oral Lead-In Phase, updated the status of study . LAI116482 (LATTE) Phase IIb</li> <li>• Section 7.4.3.4 Prompt Reporting of Serious Adverse Events and Other Events, updated text "Contacts for SAE receipt can be found at the beginning of this protocol on the Sponsor/Medical Monitor Contact</li> </ul>	<p>General safety updates</p>



Section # and Name	Description of Change	Brief Rationale
	<p>Information page in the Study Reference Manual."</p> <ul style="list-style-type: none"> <li>Section 7.4.5.4 Seizures, updated text: "Several cases of seizure have occurred during the cabotegravir program. These cases have had alternative explanations for their occurrence."</li> </ul>	
<p>Section 1.3 Overall Design Section 4.1 Overall Design</p>	<p>Removal of the reference to "randomized study treatment" in Overall design sections for alignment with CAB program studies and transition to marketed product plan.</p>	<p>Transition to marketed product</p>
<p>Section 2.3.1 Risk Assessment</p>	<p>Updated section Potential Risk of Clinical Significance: Effects in late stage pregnancy seen in non-clinical studies Summary of Data/Rationale for Risk Animal reproduction studies data updated Mitigation Strategy updated to allow participants who become pregnant to remain in the study.</p>	<p>To allow participants who become pregnant to remain in the study</p>
<p>Section 2.3.1 Risk Assessment</p>	<p>Added new category: : Potential Risk of Clinical Significance Potential effects in females exposed to dolutegravir during conception and early pregnancy. Summary of Data/Rationale for Risk with data from preliminary analysis of an ongoing birth outcome surveillance study in Botswana involving women exposed to dolutegravir (DTG). Mitigation Strategy updated to allow participants who become pregnant to remain in the study.</p>	<p>To allow participants who become pregnant to remain in the study</p>
<p>Section 2.3.1 Risk Assessment</p>	<p>Removed text from RPV risks, Rash mitigation strategy: Participants with a Grade 1 or 2 rash will be allowed to continue treatment or to be rechallenged , depending on the clinical judgment of the investigator.</p>	<p>Removal of rechallenge option</p>
<p>Section 3 Objectives and Endpoints</p>	<p>Added text in bold: Preference for CAB LA + RPV LA every 8 weeks or every 4 weeks compared to daily oral for participants receiving oral bridging during the Maintenance and/or Extension phases will be assessed using a preference questionnaire at Week 152 <b>or Withdrawal</b></p>	<p>Clarification required to be consistent with T&amp;E table: Reason for OB and Preference questionnaire requirements at WD in the extension phase</p>
<p>Section 5.3 Additional Eligibility Criteria</p>	<p>Added text: Participation in other interventional studies is generally not permitted, however for eligible participants in South Africa co-enrolment in the AIDS Clinical Trial Group ACTG interventional study (A5392) could be exceptionally permitted after review and approval by Medical Monitor.</p>	<p>Co-enrolment in study A5392 would be permitted in South Africa on a case by case approval basis.</p>
<p>Section 5.5 Withdrawal/Stopping Criteria</p>	<p>Updated text to clarify the process for participants that discontinue participation when CAB LA + RPV LA is locally available</p>	<p>Transition to marketed product</p>

Section # and Name	Description of Change	Brief Rationale
	Removed text: Pregnancy (intrauterine), regardless of termination status of pregnancy.	To allow participants who become pregnant to remain in the study
Section 5.5.1.	Removed "rechallenge" option throughout the sections  Rechallenge option removed throughout all sections New text updated with the current process required in case of restart throughout the section: <ul style="list-style-type: none"> <li>- 5.5.1.3 Liver Chemistry Stopping Criteria - Restart</li> <li>- 5.5.1.4 General Guidance Restart</li> <li>- 5.5.1.4.1 Drug Restart</li> </ul> 5.5.1.4.2 Drug Restart Following Transient Resolving Liver Events Not Related to IP	Rechallenge option removed
Section 5.6 Participant and Study Completion	Updated text to clarify the Safety Follow up visit requirements	Transition to marketed product
Section 6.10 Discontinuation of Study Treatment	Text added to clarify the process for participants that transition from study treatment to marketed product.	Transition to marketed product
Section 6. Study Treatment	New section added: 6.14 Medical Devices	Medical Device reporting requirement
Section 7.1. Time and Events table	Safety FU visit additional text added to clarify visit requirements	Transition to marketed product
Section 7.1 Time and Events Table	Added new column to list WD assessments during Extension phase Clarification added to the pre-existing WD column to indicate it only refers to WD visit occurred during Maintenance phase  Amended footnotes to clarify requirements for participants who become pregnant during the study  Amended footnotes to clarify the questionnaires required at W152 and WD visit in the Extension phase Withdrawal only if occurring at or prior to Week 152 to Conduct questionnaires/surveys at Withdrawal only if occurring at or prior to Week 152.	To clarify the WD and W152 assessments in the extension phase and add PK testing in case of pregnancy.
Section 7.4.1 Clinical Evaluation	Added text: Participants who are enrolled in the study and have a positive pregnancy test during the course of the study, will be allowed to remain in the study, provided a pregnancy specific ICF addendum is signed by the participant. No IP can be continued (oral or LA) in any pregnant participant until the benefit/risk assessment is discussed with the participant and the pregnancy specific ICF addendum has been signed. See details in Appendix 11. Pregnant participants who remain in the study do not need pregnancy testing during the study, for the duration of their pregnancy.	To allow participants who become pregnant to remain in the study

Section # and Name	Description of Change	Brief Rationale
Section 7.4.3 Adverse Events (AE) and Serious Adverse Events (SAEs)	<p>Added text throughout Section 7.4.3. and Section 7.4.3.1. referring to the new requirement to report Medical Device incidents.</p> <p>New sections added to cover the new requirement to report Medical Device incidents.</p> <p>7.4.3.9 Medical Device Deficiencies:</p> <p>7.4.3.9.1 Time period for Detecting Medical Device Deficiencies</p> <p>7.4.3.9.2 Follow-up of Medical Device Deficiencies</p> <p>7.4.3.9.3 Prompt Reporting of Medical Device Deficiencies to Sponsor</p> <p>7.4.3.9.4 Regulatory Reporting Requirements for Medical Device Deficiencies</p>	Added Medical Device incidents reporting requirement
Section 7.4.7 Pregnancy	<p>Added text throughout all sections below to allow participants who become pregnant to remain in the study:</p> <p>Added text in Section 7.4.7.1</p> <p>Added new Section 7.4.7.2</p> <p>Amended Section 7.4.7.3</p> <p>Amended Section 7.4.7.4</p>	To allow participants who become pregnant to remain in the study
Section 7.4.7.4 Action to be taken if Pregnancy occurs	Removed text: Additionally, there will be an optional umbilical cord blood collection at time of delivery and/or breast milk after delivery, requiring additional parental informed consent. Cord blood and breast milk samples would be used to better understand the level of PK exposure to the neonate, if any.	Removal of optional umbilical cord blood and/or breast milk pk testing
Section 7.5. Pharmacokinetics	Added text: Pregnant participants will have additional PK samples collected during the duration of the pregnancy.	Added PK collection during pregnancy
Section 7.8.2. Value Evidence and Outcomes endpoints (Exploratory)	<p>Added text: A preference questionnaire will be administered to participants receiving oral bridging during the Maintenance and/or Extension Phases in order to explore preference for CAB + RPV LA Q4W or Q8W compared to daily oral HIV medication <b>at W152 or upon WD visit if occurred at or before Week 152.</b></p> <p>Section 7.8.3. Guidance for administering the different versions of HIVTSQc, Preference and Reason for Switch Questionnaires in ATLAS-2M</p>	Added clarification of Preference questionnaires completion in the extension phase

Section # and Name	Description of Change	Brief Rationale
Section 11.3. Appendix 3	Updated Appendix 3: Liver Safety – Required actions, Follow up Assessments and Study Treatment Restart Guidelines	Removal of rechallenge option
Section 11.5. Appendix 5 Genetics research	Text updated: In the event a participant withdraws from the study and requests destruction of their samples then the site staff must document this in the site study records, complete form F-GRD-001 and must inform ViiV/GSK via the CRA within 5 days of notification by the participant to trigger sample destruction requests.	To align with most recent template requirements
Section 11.7. Appendix 7: Contraceptive Guidance and Collection of Pregnancy Information	Removed footer b of table 14 Highly Effective contraceptive Methods: Two highly effective methods of contraception should be utilized from 30 days prior to the first dose of study medication, throughout the study, and for at least 52 weeks after discontinuation of CAB LA and RPV LA .	Permitted contraceptive methods updated
Section 11.7. Appendix 7: Contraceptive Guidance and Collection of Pregnancy Information	Added text throughout this section for cases of pregnancy during the study	To allow participants who become pregnant to remain in the study
Section 11.8.3. Informed Consent Process	Text added to cover the process for participants that become pregnant and wish to continue in the study. Text added to cover the process for a non-participant that experiences a medical device incident with an AE.	Informed consent process required for pregnant participants who wish to continue participating in the study and non-participants who result injured due to Medical device incident
Section 11.8.7. Data Quality Assurance	Text added (in bold): The sponsor or designee is responsible for the data management of this study including quality checking of the data. <b>Detailed information about study data collection and management process including systems used can be found in the study Data Management Plan.</b>	For clarification purposes
Section 11.10.6.1. Capturing COVID-19 Specific Protocol Deviations	Removed text: Please refer to your study procedure manual for specific details on capturing protocol deviations as a result of COVID-19.	For clarification purposes.
Section 11.11.	New appendix added: Appendix 11: Information and Guidance for Managing Pregnant Participants	To allow participants who become pregnant to remain in the study
Section 11.12.	New appendix added: Appendix 12: Device Deficiencies: Definition and Procedures for	Medical Device reporting requirement

Section # and Name	Description of Change	Brief Rationale
	Recording, Evaluating, Follow-up, and Reporting in Medical Device Studies	
Section 11.13.	Appendix 13: Protocol Amendment history updated	

**Amendment 04 – 05-Aug-2020**

**Overall Rationale for Amendment 4**

The primary reasons for protocol amendment 04 are to add a formal efficacy and safety secondary analysis at Week 152, allowing participants to continue treatment with randomized study medication through at minimum the Week 152 timepoint. The study endpoints and additional assessments in support of the planned secondary analyses have been updated for Week 152. Health outcomes assessments including the HIV-TSQs, Accept, and PIN questionnaires are included at Week 152 to gain further insight into participant’s long-term treatment experience with Long-acting Cabotegravir Plus Long-acting Rilpivirine. The Preference questionnaire will also be administered at Week 152 only to participants who received oral bridging during the Maintenance and/or Extension Phases. Additional minor clarifications to protocol language have also been incorporated.

Section # and Name	Description of Change	Brief Rationale
<p>Synopsis Section 1.1 Rationale</p> <p>Synopsis Section 1.3 Overall Design</p> <p>Synopsis Section 1.4.2 Maintenance Phase</p> <p>Section 2.1 Study Rationale</p> <p>Section 4.2.2 Maintenance Phase</p> <p>Section 4.2.3 Extension Phase</p> <p>Section 4.4 Scientific Rationale for Study Design</p> <p>Section 6.12 Treatment after the End of Study</p> <p>Section 7.4.2-Table 8 (Table text and footnote both)</p>	<p>Week 152 timepoint has been added within multiple protocol sections.</p>	<p>To enable Week 152 safety and efficacy formal analyses</p>
<p>Section 1.2 and Section 3.0 Objectives and Endpoints</p>	<p>Added Week 152 to secondary and exploratory endpoints</p> <p>Added new exploratory objective and Endpoint to assess patient preference for CAB LA + RPV LA every 8 weeks or every 4 weeks compared to daily oral for participants receiving oral bridging during the Maintenance and/or Extension phases</p>	<p>To enable Week 152 safety and efficacy formal analyses</p>
<p>Section 1.3.1 and Section 4.1 Overall Design, Study Schematic</p>	<p>Added Week 152 Endpoint to Study Schematic</p>	<p>To enable Week 152 safety and efficacy formal analyses</p>

Section # and Name	Description of Change	Brief Rationale
Section 1.4.3 and Section 4.2.3 Extension Phase	Text in bold was added:  Participants who successfully complete 96 Weeks of CAB LA + RPV LA treatment in the Maintenance Phase will continue to have access to their randomized treatment Q4W or Q8W CAB LA + RPV LA in the Extension Phase <b>through Week 152</b> and until study treatment is either locally approved and commercially available...	Extends participant access to randomized study treatment through Week 152 at minimum.
Section 1.4.4 Long-Term Follow-Up Phase	Text in bold was added:  Investigators must discuss the choice of the follow-up HAART regimen with the Medical Monitor prior to initiating the new regimen with the participant. HAART therapy should be initiated within 4 weeks ( <b>+7 days</b> ) after the last Q4W injection, or within 8 weeks ( <b>+7 days</b> ) after the last Q8W injection	Clarification is added to the allowed window for initiation of HAART therapy following the last CAB LA + RPV LA IM injections received.
Section 5.5 Withdrawal/Stopping Criteria	Text in bold was added:  If withdrawal coincides with the active planned Week 52, Week 100, <b>or Week 156 (Q4W arm)</b> visits, HIV-1 RNA will only be assessed if the last HIV-RNA measurement from Week 48, Week 96, <b>or Week 152</b> was $\geq 50$ copies per mL (i.e. retest for viral load blip). This will ensure that only the Week 48, Week 96, <b>and Week 152</b> viral load assessments or required retest will be counted towards the primary and secondary efficacy endpoint windows.	Maintains consistency with HIV-1 RNA analysis and retest strategy
5.5.5.1 HIV-1 RNA Blips	Text in bold was added:  Participants who have a HIV-1 RNA $\geq 50$ c/mL and $< 200$ c/mL at the key analysis timepoints (Week 48, Week 96, <b>and Week 152</b> ) must return to	Incorporates similar HIV-1 RNA retesting strategy for Week 152 visit that was utilized for prior Week 48 and 96

Section # and Name	Description of Change	Brief Rationale
	the clinic as soon as possible (but no later than 4 weeks after the date of the Week 48, 96, or 152 visit, respectively	timepoints.
6.8.1 Oral Bridging	The following text was added: <b>Participants who withdraw during an oral treatment period must be initiated on HAART therapy within 24 hours after the last oral treatment with CAB + RPV.</b>	Clarification regarding guidance for initiation of HAART therapy for participants withdrawing during oral treatment.
7.1.1 and 7.1.2 Time and Events Tables.	Week 152 efficacy, safety, and Health Outcomes assessments have been added to support the additional secondary and exploratory analyses. T&E table footnotes are correspondingly updated.	To enable Week 152 safety and efficacy and Health Outcomes formal analyses
7.4.3.5 Disease-Related Events and/or Disease-Related Outcomes Not Qualifying as SAEs	Text in bold was added: <b>If any of the above conditions is met, then record the event on either the AE or SAE page (according to severity) in addition to the HIV Associated Conditions eCRF page. If it is categorized as an SAE, report promptly (i.e., expedited reporting, see Section 7.4.3.4) to GSK.</b>	Clarifies that disease related events (DREs) or outcomes listed in the CDC Classification System for HIV-1 Infections are also to be entered on the HIV associated conditions eCRF page.
7.5.1 PK Sample Collection- Table 10 CAB and RPV Plasma Pharmacokinetic Sample Schedule	Added PK Sample Collections for planned analysis at Week 152 (Table 10)	PK sampling added in support of planned Week 152 safety and efficacy formal analyses
7.8.1 Value Evidence and Outcomes Endpoints (Secondary)	Health outcomes assessments including the HIV-TSQs, Accept, and PIN questionnaires are included at Week 152.	Health Outcome Measurements added at Week 152 are purposed to gain further insight into participant's long-term treatment experience with Long-acting Cabotegravir Plus Long-acting Rilpivirine.



Section # and Name	Description of Change	Brief Rationale
Section 7.8.2 (Value Evidence and Outcomes Endpoints (Exploratory))	<p>Text in bold was added:</p> <p><b>A preference questionnaire will be administered to participants receiving oral bridging during the Maintenance and/or Extension Phases in order to explore preference for CAB + RPV LA Q4W or Q8W compared to daily oral HIV medication</b></p>	<p>Health Outcome Measurements added at Week 152 are purposed to gain further insight into participant’s long-term treatment experience with Long-acting Cabotegravir Plus Long-acting Rilpivirine.</p>
<p>9.2.3 Planned Analyses</p> <p>9.3.2.2. Other Secondary Endpoint Analyses</p> <p>9.3.9 Other Analyses</p>	<p>Text in bold was added:</p> <p>The number of planned analyses was updated to state that at least <b>four</b> analyses will be conducted to evaluate the objectives of the protocol after all participants have completed their visits at Week 24, Week 48, Week 96, <b>and Week 152</b> respectively</p> <p>Week 152 endpoints are added within the planned statistical analyses sections.</p>	<p>To enable Week 152 safety and efficacy formal analyses</p>

**Amendment 03** 21-May-2020**Overall Rationale for Amendment 3:**

The primary reason for protocol amendment 03 is to include information on Covid-19 specific guidance for clinical trial continuity (participant and study management) during the pandemic. This information is included within Appendix 10: COVID-19 Pandemic and Clinical Trial Continuity.

**Amendment 02** 03-Jul-2018

**Overall Rationale Amendment 2:** The primary reasons for amendment #2 are to:

- Add the additional interim analysis of data when all participants have completed the Week 24 visit, with the intent of expediting the submission of study results to Health Authorities;
- Change the objective for assessing the preference for CAB LA + RPV LA every 8 weeks or CAB LA + RPV LA every 4 weeks LA compared to oral antiretroviral (ARV) and the preference for CAB LA+ RPV LA every 8 weeks compared to CAB LA + RPV LA every 4 weeks from an exploratory objective to a secondary objective. A change to the supporting version of the Preference questionnaire administered to participants at Week 48 (or withdrawal) is also acknowledged;
- Add revisions and clarifications for the administration of health outcomes questionnaires;
- Extend exclusion criterion #28 to also exclude hereditary coagulation and platelet disorders such as haemophilia or Von Willebrand Disease;
- Update exclusion criterion #11 to indicate that CD4+ counts <200 cells/ $\mu$ L are not exclusionary;
- Offer clarification that withdrawal assessments will be performed for any participant who withdraws prematurely from the Maintenance or Extension Phase. Additional guidance for participants withdrawing at Week 52 or Week 100 has been added;
- Offer guidance to monitor medications that are dependent on OAT1 and OAT3 transport upon concomitant exposure with CAB;
- Specify that 2-hour post-dose ECG should be performed at Day 1 and Week 48 only for participants receiving CAB LA + RPV LA as it is not required to perform 2-hour post-dose ECG for those receiving oral CAB + RPV at Day 1;
- Exclude language that previously indicated hormonal contraception may be susceptible to interaction with the study drugs. The lack of a demonstrated interaction with a representative contraceptive supports use of CAB and RPV across a broad range of estrogen and progestin or progestin only hormonal contraceptives;

- Add minor clarifications and corrections to typographical errors/formatting to protocol text.

Section # and Name	Description of Change	Brief Rationale
Synopsis Section 1.4.2, and Section 4.2.2, Maintenance Phase (Day1 up to Week 100), CAB LA + RPV LA Dosing Regimens in ATLAS-2M	Clarified for Q8W cohort transitioning from Oral Standard of Care (SOC) that CAB LA + RPV LA is administered at Week 4b, Week 8, & Q8W thereafter. (Week 8 was added)	Week 8 dosing for this group was inadvertently omitted in Amendment #1 of the prior protocol within these sections and is now updated for consistency with the intended dosing administration in other sections of the protocol.
Synopsis Section 1.2, Section 3 Objectives and Endpoints;	Select secondary efficacy and safety endpoints have been updated to include Week 24 endpoints.	Adds the additional analysis of data through Week 24 with the intent of expediting the submission of study results to Health Authorities
Synopsis Section 1.2, Section 3 Objectives and Endpoints; Section 7.8, Value Evidence and Outcomes; Section 7.8.1, Value Evidence and Outcomes Endpoints (Secondary); Section 9.3.7, Health Outcomes Analyses.	Assessment of the preference for CAB LA + RPV LA every 8 weeks or CAB LA + RPV LA every 4 weeks LA compared to oral antiretroviral (ARV) and the preference for CAB LA+ RPV LA every 8 weeks compared to CAB LA + RPV LA every 4 weeks is changed from an exploratory objective to a secondary objective of ATLAS-2M. The description of the Preference questionnaire is updated to reflect the revised questionnaire. The Preference questionnaire will be captured at Week 48 or Withdrawal if prior to Week 48.	The version of the Preference questionnaire has been updated and re-purposed as a secondary objective for the ATLAS-2M trial.
Section 4.2.4, LTFU Phase-IM Regimen Only	Window for initiating HAART therapy during the LTFU Phase has been added:  HAART therapy should be initiated within 4 weeks ( <b>± 7 days</b> ) after the last Q4W injection, or within 8 weeks ( <b>± 7 days</b> ) after the last Q8W injection.	Allowable window for the initiation of HAART therapy ensures timely start of HAART during the LTFU Phase to approximate exposure coverage for CAB LA + RPV LA.

Section # and Name	Description of Change	Brief Rationale
Section 5.2, Exclusionary Criteria	<p>Exclusion criterion #28 has been extended to also exclude hereditary coagulation and platelet disorders such as haemophilia or Von Willebrand Disease.</p> <p>Exclusion criterion #11 has been updated to indicate that CD4+ counts &lt;200 cells/<math>\mu</math>L are not exclusionary.</p>	<p>Due to recurring intramuscular injections, participants with coagulation disorders are excluded.</p> <p>HIV Stage 3 disease is excluded with the exceptions of cutaneous Kaposi's sarcoma not requiring systemic therapy, and CD4+ counts &lt;200 cells/<math>\mu</math>L are not exclusionary.</p>
Section 5.5, Withdrawal/Stopping Criteria; Section 1.4.4, Long-Term Follow-Up Phase	Text has been added to provide additional instruction regarding withdrawal assessments to be performed for participants withdrawing from the Maintenance or Extension Phase	Clarification has been added on when and how to perform withdrawal assessments relative to the time of individual participant withdrawal.
Section 5.6 Participant and Study Completion	<p>Text has been added to clarify the definition of a study completer:</p> <p>Randomly assigned to either treatment group, completed the randomized Maintenance Phase including Week 100 (<b>with or without Week 100 study treatment</b>) and did not enter the Extension Phase.</p>	Study completers will include those participants who complete Week 100 protocol procedures and assessments without study treatment at Week 100 should those participants not enter into the study Extension Phase.
Section 6.1 Investigational Product and Other Study Treatment	IP Storage requirements have been updated to indicated that study IP is to be stored according to the product labeling.	Specific IP storage and temperature requirements have been removed from the text as the storage conditions are subject to updates during the course of the trial which could lead to inconsistencies with the approved protocol. Storage requirements will be incorporated in product labeling and supporting trial documentation which can be referenced separately from the protocol.

Section # and Name	Description of Change	Brief Rationale
Section 6.13.2, Prohibited Medications and Non-Drug Therapies	<p>The following text is added:</p> <p><b>Concurrent with CAB</b></p> <p>CAB is a potent inhibitor of OAT1 and OAT3 transport in vitro, however, no clinically significant interaction risk is expected for most drugs that are substrates of these transporters. Monitoring may be required for drugs with a narrow therapeutic index and dependent on OAT1 and OAT3 transport (e.g. methotrexate) with concomitant CAB administration. Refer to the current Investigator's Brochure (Section 4.3.6.1 and Section 6.4) for additional information.</p>	Additional guidance is offered for monitoring of medications dependent on OAT1 and OAT3 transport upon concomitant exposure with CAB.
Section 7.1, Time and Events Table for Q4W and Q8W arms.	Footnote c updated to: for Weeks 4a and 96: Confirmation of eligibility to <b>continue</b> <del>enter</del> the Maintenance Phase and eligibility to enter the Extension Phase	Clarification of text
Section 7.1, Time and Events Table for Q4W and Q8W arms.	Footnote h updated to: A 12-lead ECG will be performed after resting in a semi-supine position for at least 5 minutes. ECGs will be performed pre-dose. For participants transitioning from ATLAS, the pre-dose Week 48 ECG can also serve as the ATLAS-2M Screening ECG. ECG pre-dose will be performed in triplicate at Day 1. A 2-hour post-dose ECG will also be performed at Days 1 and Week 48 for participants receiving CAB LA + RPV LA with an allowable window of $\pm$ 30 minutes.	Additional guidance is provided for any Screening CGs overlapping with ATLAS Week 48 for ATLAS rollover participants. Language added to specify that 2-hour post-dose ECG should be performed at Day 1 and Week 48 only for participants receiving CAB LA + RPV LA as it is not required to perform 2 hour post-dose ECG for those receiving oral CAB + RPV at Day 1.

Section # and Name	Description of Change	Brief Rationale
Section 7.1, Time and Events Table for Q4W and Q8W arms.	Footnote r updated to:  One blood sample for CAB and RPV each to be collected at each PK timepoint. PK samples are to be collected pre-dose relative to IM administration. At Week 4b, Pre-dose samples are to be collected after review of PK diary provided at Day 1 and prior to the final oral dose of CAB + RPV for participants randomized from SOC. PK window allowed for sample collection is 3 to 10 days for 1 wk post dose sample (Visits 9 and 41).	Clarification of timing for pre-dose PK sample collection at Week 4b for participants randomized from oral SOC.
Section 7.1, Time and Events Table for Q4W and Q8W arms.	Footnote u updated to: All Patient Report Questionnaires/Surveys will be administered via paper instrument at the beginning of the visit before any other assessments are conducted and prior to administration of the eC-SSRS. Conduct questionnaires/surveys upon Withdrawal only if occurring at or prior to Week 48.	Clarification that all patient reported questionnaires are to be administered together at the beginning of the visit prior to all other assessments.
Section 7.1, Time and Events Table for Q4W and Q8W arms.	Footnote v updated to: Clarification that versions of the HIV-TSQc are to be administered to all participants transitioning from ATLAS and new participants transitioning from oral SOC. For participants transitioning from ATLAS, the version of the HIV-TSQc instrument to be administered will be based on the initial randomization arm at ATLAS Day 1	Distinct versions of the HIVTSQc have been developed for all participants including those transitioning from ATLAS and new participants transitioning from oral SOC

Section # and Name	Description of Change	Brief Rationale
Section 7.1, Time and Events Table for Q4W and Q8W arms.	Footnote w updated to:  For patients randomized to oral SOC at Day 1 in ATLAS or new patients on SOC, the reasons for willingness to switch ART will be assessed at Day 1. For patients randomized to CAB LA + RPV LA Q4W in ATLAS, the reasons for willingness to continue long-acting ART in ATLAS-2M will be assessed at Day 1.	Additional clarification on administration of Reason for Switch and Reason for Continuation for patient groups.
Section 7.1, Time and Events Table for Q4W and Q8W arms.	Footnote X updated to: Preference Questionnaire will be administered to all participants.	The version of the Preference questionnaire has been revised under Protocol Amendment #2 and will be administered to all study participants.
Section 7.1, Time and Events Table for Q4W and Q8W arms.	Footnote Y has been added: Refer to Section 5.5 of the protocol for additional information on performing withdrawal assessments. HIV-1 RNA will be collected as Storage sample only if withdrawal assessments coincide with Week 52 or Week 100 (as per Section 5.5.)	Reference to Section 5.5. for withdrawal assessments has been added to ensure appropriate sample collections are performed.
Section 7.1, Time and Events Table for Q4W and Q8W arms and throughout protocol	Footnote Z and throughout protocol, Month 1 of the Long-Term Follow-Up (LTFU) visit has been removed such that participants receiving one or more injections with CAB LA and/or RPV LA will be assessed with clinic visits at a withdrawal visit, and months, 3, 6, 9 and 12 during the Long-Term Follow-Up Phase	Withdrawal assessments conducted during withdrawal visit will serve as the first set of follow-up assessments for the LTFU Phase, followed by planned visits at months 3, 6, 9, and 12 following the last CAB LA + RPV LA injections received.

Section # and Name	Description of Change	Brief Rationale
Section 7.4.3.1: Time period and Frequency for collecting AE and SAE information	The following text has been removed:  <del>During the Extension Phase, AEs leading to Withdrawal and all SAEs will be recorded.</del>	Clarification and to add consistency with other text that all AEs will be collected from the start of study treatment until the final follow-up contact
Section 7.4.10, Electrocardiogram (ECG)	The following text has been added: At Day 1 and Week 48 of the Maintenance Phase, a 2 hour post dose ECG will be performed <b>for participants receiving CAB LA + RPV LA with an allowable window of <math>\pm</math> 30 minutes</b>	Adds clarification that the 2 hour post-dose ECG is only for those participants receiving CAB LA RPV LA at Day 1, and specifies the allowable window for conduct of the ECG.
Section 7.8.3 Guidance for administering the different versions of HIVTSQc, Preference and Reason for Switch Questionnaires in ATLAS-2M	Section 7.8.3 has been added including a table to guide administration of Evidence and Outcomes instruments	Additional guidance towards Value Evidence and Outcomes instruments has been added to assist investigative staff with administration of different versions of these patient questionnaires.
Section 9.2.2.1: Primary Comparison of Interest	Treatment with Q8W will be declared non-inferior to Q4W if the upper end of a two-sided 95% confidence interval for the difference between the two groups (Q8W – Q4W) in the proportion of participants with HIV-RNA $\geq$ 50 c/mL at Week 48 (defined by the US FDA snapshot algorithm) lies below 4%.	Section 9.2.2.1 Primary Comparison of Interest erroneously referred to a non-inferiority declaration of the Q8W regimen relative to the Q4W regimen if the difference in the proportion of participants with HIV-RNA $\geq$ 50 c/mL between the two groups lies below 5% rather than the intended update to 4%.
Section 9.2.3.1 Week 24 data analyses	Section 9.2.3.1 has been added to describe the additional analyses of early data through Week 24.	Adds the additional analysis of data through Week 24 with the intent of expediting the submission of study results to Health Authorities



Section # and Name	Description of Change	Brief Rationale
Appendix 7: Contraceptive Guidance and Collection of Pregnancy Information	<p>Footnote b from Table 14 has been modified to exclude language indicating that hormonal contraception may be susceptible to interaction with the study drugs.</p> <p><del>Hormonal contraception may be susceptible to interaction with the study drug, which may reduce the efficacy of the contraceptive method. In this case</del></p> <p>b. Two highly effective methods of contraception should be utilized from 30 days prior to the first dose of study medication, throughout the study, and for <u>at least 52 weeks</u> after discontinuation of CAB LA and RPV LA.</p>	<p>CAB and RPV have demonstrated no impact on the pharmacokinetics of commonly used combined estrogen and progestin containing oral contraceptives. Neither CAB nor RPV induce or inhibit UGT or CYP enzymes which are the predominant metabolic routes of elimination for these products. The interaction has only been studied with levonorgestrel/ethinyl estradiol for CAB and norethindrone/ethinyl estradiol for RPV. The lack of a demonstrated interaction with a representative contraceptive supports use of CAB and RPV across a broad range of estrogen and progestin or progestin only hormonal contraceptives.</p>
General Updates	Additional minor clarifications and corrections to typographical errors/formatting to protocol text have been added.	Text clarifications and formatting

### Amendment 01 14-Sep-2017

**Overall Rationale for Amendment #1:** The primary purpose of protocol amendment #1 is to revise the study sample size to randomize approximately 1020 participants including 510 participants per arm based on a non-inferiority margin of 4% between the CAB LA + RPV LA Q8W and Q4W arms. Assuming the true proportion with HIV-RNA  $\geq 50$  c/mL is 3% for the Q8W arm and 2% for the Q4W arm, the revised sample size will provide at least 85% power to show non-inferiority at Week 48. Additional minor clarifications and corrections have been added to the protocol text.

Section # and Name	Description of Change	Brief Rationale
Synopsis Short Title	Protocol short title updated to be consistent with short title of title page.	Short title consistency
General Updates throughout protocol	Update of noninferiority margin and corresponding study participant size and statistical powering.	Increase of sample size to 1020 participants to support 4% non-inferiority margin and 85% power assuming a true 3% failure rate for Q8W arm and 2% failure rate for the Q4W arm.
Section 4.2.6 Independent Data Monitoring Committee	Clarification of IDMC analysis	Clarification added that IDMC will focus evaluation of efficacy, tolerability, safety, and PK on accumulating CAB LA + RPV LA Q8W data
Section 5.5 Withdrawal/Stopping Criteria.	Bullet # 4 under reasons participants must be discontinued from study treatment updated to: “Participant requires substitution of ART”.	Dose modification of CAB or RPV is not an available option to participants.
Section 5.6 Participant and Study Completion	Text updated to: In addition to the 52-week Follow-Up phase required for participants who receive one or more injections with CAB LA or RPV LA, an in-clinic Follow-Up visit will be conducted approximately 4 weeks after the last dose of study medication for participants who withdraw during the oral lead-in phase with ongoing AEs, and serious adverse events (SAEs) and also any laboratory abnormalities that are considered to be AEs or potentially harmful to the participant, at the last on-study visit.	Clarification of required procedures for Long-term Follow-up Phase and follow-up visit for participants with ongoing AEs, SAEs, or laboratory abnormalities.

Section # and Name	Description of Change	Brief Rationale
Section 6.1 Investigational Product and other Study Treatment	Text updated to: Participants entering the Long-Term Follow-Up Phase will not have their selected HAART provided as clinical trial material. The selected HAART will be recorded on the Concomitant Antiretroviral Therapy (ConART) eCRF page.	Clarification that HAART selected during Long-Term Follow-Up Phase will not be provided as clinical trial material and removal of reference to current ART.
Section 6.9 Interruption of Study Treatment and Visit/Dosing Windows	Text updated to: IP may be interrupted at the discretion of the Investigator in the event of an AE, according to the severity of the AE.	Removal of reference to current ART
Section 6.9.1.1: IM injections every 4 weeks (Q4W)	Text updated to: The first injection visit with IM CAB LA + RPV LA at Week 4b can be performed once central lab results are available and safety parameters are reviewed from the Week 4a visit.	Text updated to indicate first injections received at Week 4b rather than Day 1 for consistency with Time and Events Table.
Section 6.13.2.3: Prohibited Medications for Participants Receiving HAART during the Long-Term Follow-Up Phase	Text updated to: For participants taking HAART during the Long-Term Follow-Up Phase, refer to local prescribing information for details regarding concurrent therapies.	Clarification that local prescribing information should be referenced for HAART taken during Long-Term Follow-Up Phase regarding prohibited concurrent therapies.
Section 7.1, Time and Events Table for Q4W and Q8W arms.	Text added to footnote q, for genetics sample. Sample may be collected at any visit after signing informed consent, but preferably at the Day 1 visit.  Footnotes added to Preference and HIVTSQc questionnaires.	Adds flexibility to when genetic sample for genetic research can be obtained.  Added clarification for intended administration of questionnaires to participant groups.

Section # and Name	Description of Change	Brief Rationale
	<p>eCSSRS questionnaire removed from study Extension Phase.</p> <p>Removal of reference to collection of Health Outcomes data via electronic site pads for footnote “u”</p>	<p>Suicidality assessment tool administered through study Week 96 or withdrawal.</p> <p>Collection of Health Outcomes data will be performed via paper instruments.</p>
<p>Section 7.4.3.4: Prompt Reporting of Serious Adverse Events and Other Events</p> <p>Table 9: Reporting of Serious Adverse Events and Other Events</p>	<p>Text updated to: Suspected ABC HSR in participants receiving Oral SOC during the Long-Term Follow-Up Phase<sup>b</sup></p> <p>Initial report of pregnancy and completion of Pregnancy Notification Form has been updated to within 24 hours of identification of a Pregnancy event. Follow-up Pregnancy form (and SAE if required) has been updated to within 24 hours of investigator awareness of pregnancy outcome.</p>	<p>Clarification for reporting suspected ABC HSR adverse event is relevant only during the Long-Term Follow-Up Phase for participants returning to Oral Standard of Care</p> <p>Reporting timelines and documentation requirements have been updated to reflect current Sponsor requirements.</p>
<p>Section 7.4.5.7.1 Proximal Renal Tubule Dysfunctions (PRTD)</p>	<p>Text removal: <del>). If a participant in the current ART arm is also receiving TDF, then a dose adjustment may be considered if restarting study drug unless participants met renal toxicity stopping criteria (see Section 7.4.5.7)</del></p>	<p>Removal of reference to current ART therapy dose adjustments.</p>

<b>Section # and Name</b>	<b>Description of Change</b>	<b>Brief Rationale</b>
Section 7.8 Value Evidence and Outcomes	Removal of reference to collection of Health Outcomes data via electronic site pads.	Collection of Health Outcomes data will be performed via paper instruments.
Section 9 Statistical Considerations and Data Analyses	Updates to sample size, analysis considerations, and planned analysis within Section 9.1- Section 9.3. have been added	<p>Updates to statistical section required based on change of noninferiority margin from 5% to 4%, corresponding increase in study participant size, impact on sample size sensitivity analysis.</p> <p>Additional details for subgroup and stratum-specific analysis plan are included.</p>
General Updates	Additional minor clarifications and corrections to typographical errors/formatting to protocol text have been added.	Text clarifications and formatting