

Protocol I3Y-CR-JPBQ(e)

A Randomized, Double-Blind, Placebo-Controlled, Phase 3 Study to Compare NSAI (Anastrozole or Letrozole) plus Abemaciclib, a CDK4 and CDK6 Inhibitor, or plus Placebo, and to Compare Fulvestrant plus Abemaciclib or plus Placebo in Postmenopausal Women with Hormone Receptor-Positive, HER2-Negative Locoregionally Recurrent or Metastatic Breast Cancer

NCT02763566

Approval Date: 14-May-2019

**1. Protocol I3Y-CR-JPBQ(e)  
A Randomized, Double-Blind, Placebo-Controlled, Phase  
3 Study to Compare NSAI (Anastrozole or Letrozole) plus  
Abemaciclib, a CDK4 and CDK6 Inhibitor, or plus Placebo,  
and to Compare Fulvestrant plus Abemaciclib or plus  
Placebo in Postmenopausal Women with Hormone  
Receptor-Positive, HER2-Negative Locoregionally  
Recurrent or Metastatic Breast Cancer**

**Confidential Information**

The information contained in this protocol is confidential and is intended for the use of clinical investigators. It is the property of Eli Lilly and Company or its subsidiaries and should not be copied by or distributed to persons not involved in the clinical investigation of abemaciclib, unless such persons are bound by a confidentiality agreement with Eli Lilly and Company or its subsidiaries. This document and its associated attachments are subject to United States Freedom of Information Act Exemption 4.

**Abemaciclib (LY2835219)**

This is a randomized, double-Blind, placebo-controlled, phase 3 study to compare NSAI plus abemaciclib, a CDK4 and CDK6 Inhibitor, or plus placebo, and to compare fulvestrant plus abemaciclib or plus placebo in postmenopausal women with hormone receptor-positive, HER2-negative locoregionally recurrent or metastatic breast cancer

Eli Lilly and Company  
Indianapolis, Indiana USA 46285

Protocol Electronically Signed and Approved by Lilly on: 28 Jan 2016  
Amendment (a) Approved by Lilly: 05 December 2016  
Amendment (b) Electronically Signed and Approved by Lilly: 21 March 2017  
Amendment (c) Electronically Signed and Approved by Lilly: 16 June 2017  
Amendment (d) Electronically Signed and Approved by Lilly: 7 May 2018  
Amendment (e) Electronically Signed and Approved by Lilly  
on approval date provided below

Approval Date: 14-May-2019 GMT

## 2. Synopsis

### Study Rationale

Abemaciclib is an oral, selective, and potent small molecule cyclin-dependent kinase 4 and 6 (hereafter CDK4 and CDK6) dual inhibitor with antitumor activity within multiple preclinical pharmacology models and an acceptable toxicity profile in nonclinical species. Abemaciclib mesylate has been shown to significantly inhibit tumor growth in multiple murine xenograft models for human cancer. Studies with abemaciclib across breast cancer cell lines indicate differential sensitivity to CDK4 and CDK6 inhibition based on histological and genetic characteristics. Growth inhibition in vitro across a diverse panel of 46 breast cancer cell lines, representing the known molecular subgroups of breast cancer, indicates that sensitivity to CDK4 and CDK6 inhibition is greater in estrogen receptor-positive (ER+) breast cancers with luminal histology.

In the Phase 1 Study I3Y-MC-JPBA (JPBA), abemaciclib has shown clinically manageable safety across 6 tumor-specific cohorts, with the most common treatment-emergent adverse events (TEAEs) possibly related to study drug including diarrhea, nausea, fatigue, vomiting, and neutropenia. Importantly, abemaciclib has demonstrated evidence of clinical activity in a tumor-specific cohort of women with metastatic breast cancer (mBC). In Study JPBA, 47 patients with a median of 7 prior systemic regimens received therapy with abemaciclib. Among the 36 patients with hormone receptor-positive (HR+) mBC, the median progression-free survival (PFS) was 8.8 months and there were 12 confirmed partial responses (PRs), for an objective response rate of 33.3%. In the same study, the combination of abemaciclib plus fulvestrant was also evaluated and demonstrated an acceptable safety profile in 19 women with HR+ mBC. In addition, 4 confirmed PRs were observed in these 19 patients. These results support further investigation of abemaciclib in combination with fulvestrant for women with HR+ locoregionally recurrent or metastatic breast cancer.

In another ongoing Phase 1b study, Study I3Y-MC-JPBH (JPBH), safety and tolerability of abemaciclib in combination with endocrine therapies (including anastrozole and letrozole) are also being evaluated in patients with HR+, human epidermal growth factor receptor 2-negative (HER2-) mBC.

To further confirm the safety and efficacy of abemaciclib in combination with current standard endocrine therapies (either nonsteroidal aromatase inhibitors [NSAIs] or fulvestrant) in HR+, HER2- breast cancer, 2 randomized, double-blind, placebo-controlled, Phase 3 studies, Studies I3Y-MC-JPBM and I3Y-MC-JPBL, are being conducted globally. Along with these 2 studies, this randomized, double-blind, placebo-controlled Phase 3 study, Study I3Y-CR-JPBQ (JPBQ) will evaluate the safety and efficacy of abemaciclib in combination with both endocrine therapies in mainly east Asian patients with HR+, HER2- locoregionally recurrent or metastatic breast cancer and postmenopausal status.

**Clinical Protocol Synopsis: Study I3Y-CR-JPBQ**

<b>Name of Investigational Product:</b> Abemaciclib (LY2835219)	
<b>Title of Study:</b> A Randomized, Double-Blind, Placebo-Controlled, Phase 3 Study to Compare NSAI (Anastrozole or Letrozole) plus Abemaciclib, a CDK4 and CDK6 Inhibitor, or plus Placebo, and to Compare Fulvestrant plus Abemaciclib or plus Placebo in Postmenopausal Women with Hormone Receptor-Positive, HER2-Negative Locoregionally Recurrent or Metastatic Breast Cancer	
<b>Number of Planned Patients:</b> Entered: 500 Enrolled/Randomized: 450 Completed: 450	<b>Phase of Development:</b> 3
<b>Length of Study:</b> approximately 38 months Planned first patient visit: October 2016 Planned last patient visit: July 2019 Planned interim analysis: An interim analysis is planned with 119 PFS events in the abemaciclib plus NSAI or placebo plus NSAI arms. The interim analysis of abemaciclib plus fulvestrant arm or placebo plus fulvestrant arm will also be conducted once the above mentioned interim is positive.	
<b>Objectives:</b> The primary objective of this study is to compare treatment with abemaciclib plus NSAI (anastrozole or letrozole) therapy versus placebo plus NSAI therapy with respect to PFS in postmenopausal women with HR+, HER2- locoregionally recurrent or metastatic breast cancer. The key secondary objective of this study is to compare treatment with abemaciclib plus fulvestrant therapy versus placebo plus fulvestrant therapy with respect to PFS in postmenopausal women with HR+, HER2- locoregionally recurrent or metastatic breast cancer. Other secondary objectives of this study are to compare the combination treatment of abemaciclib and NSAI therapy versus placebo plus NSAI therapy, and to compare the combination treatment of abemaciclib and fulvestrant therapy versus placebo plus fulvestrant therapy with respect to the following: <ul style="list-style-type: none"> <li>• overall survival (OS)</li> <li>• OS rate at 1 and 2 years</li> <li>• objective response rate (complete response [CR] + PR)</li> <li>• duration of response (DoR; CR + PR)</li> <li>• disease control rate (DCR; CR + PR + stable disease [SD])</li> <li>• clinical benefit rate (CBR; CR + PR + SD <math>\geq</math> 6 months)</li> <li>• safety and tolerability</li> <li>• change in symptom burden using the European Organization for Research and Treatment of Cancer Quality of Life Questionnaire-Core 30 (EORTC QLQ-C30)</li> <li>• pharmacokinetics (PK) of abemaciclib, its metabolites, NSAI, and fulvestrant.</li> </ul> The exploratory objectives of this study are: <ul style="list-style-type: none"> <li>• to compare the combination treatment of abemaciclib and NSAI therapy versus placebo plus NSAI therapy, and to compare the combination treatment of abemaciclib and fulvestrant therapy versus placebo plus fulvestrant therapy with respect to change in pain burden using the modified Brief Pain Inventory short form (mBPI-sf)</li> <li>• to explore potential biomarkers related to the mechanism of action of abemaciclib, NSAI, fulvestrant, the cell cycle, and/or the pathogenesis of breast cancer, and to correlate potential biomarkers to clinical outcomes</li> <li>• to explore if change in tumor size is associated with PFS and OS.</li> </ul>	

**Study Design:** Study JPBQ is a multicenter, randomized, double-blind, Phase 3 trial evaluating treatment of abemaciclib with NSAI (Cohort A)/fulvestrant (Cohort B) or placebo with NSAI/fulvestrant in postmenopausal women with HR+, HER2- locoregionally recurrent or metastatic breast cancer.

The study will consist of 2 patient cohorts:

- Cohort A will include approximately 300 patients with HR+, HER2- locoregionally recurrent or metastatic breast cancer meeting Inclusion Criterion 2a (see below).
- Cohort B will additionally include approximately 150 patients with HR+, HER2- locoregionally recurrent or metastatic breast cancer meeting Inclusion Criterion 2b (see below). The initiation of enrollment for patients in Cohort B will be triggered later according to Eli Lilly and Company (Lilly) global strategy.

After confirmation of eligibility, patients in each cohort will be randomly assigned on a 2:1 basis to receive abemaciclib with NSAI (Cohort A)/fulvestrant (Cohort B) or placebo with NSAI (Cohort A)/fulvestrant (Cohort B).

Patients in Cohort A will be randomized using the following stratification factors: nature of disease (visceral metastases vs. non-visceral metastases) and prior (neo)adjuvant endocrine therapy (prior therapy with disease-free interval > 12 months from completion of treatment vs. prior therapy with disease-free interval ≤ 12 months from completion of treatment vs. no prior therapy). Patients in Cohort B will be randomized using the following stratification factors: nature of disease (visceral metastases vs. non-visceral metastases) and sensitivity to endocrine therapy (primary resistance vs. secondary resistance).

**Diagnosis and Main Criteria for Inclusion and Exclusions:**

Patients are eligible to be included in the study only if they meet all of the following criteria: 1) have a diagnosis of HR+, HER2- breast cancer; 2) meet either Inclusion Criterion (2a) or (2b). Patients meeting Inclusion Criterion 2a will be enrolled in Cohort A and patients meeting Inclusion Criterion 2b will be enrolled in Cohort B. 2a) have locoregionally recurrent disease not amenable to resection or radiation therapy with curative intent or metastatic disease. In addition, patients must fulfill 1 of the following criteria: relapsed with radiologic evidence of progression more than 1 year from completion of/or with no adjuvant endocrine therapy and have received no prior endocrine therapy for locoregionally recurrent or metastatic disease; **OR** relapsed with radiologic evidence of progression less than 1 year from completion of or while receiving adjuvant endocrine therapy (except for letrozole or anastrozole) and have received no prior endocrine therapy for locoregionally recurrent or metastatic disease; **OR** presented de novo mBC and not received any prior endocrine therapy; 2b) have locoregionally recurrent disease not amenable to resection or radiation therapy with curative intent or metastatic disease. In addition, patients must fulfill 1 of the following criteria: relapsed with radiologic evidence of progression while receiving neoadjuvant or adjuvant letrozole or anastrozole, with no subsequent endocrine therapy received following progression **OR** relapsed with radiologic evidence of progression within 1 year from completion of adjuvant letrozole or anastrozole, with no subsequent endocrine therapy received following progression **OR** relapsed with radiologic evidence of progression more than 1 year from completion of adjuvant endocrine therapy and then subsequently relapsed with radiologic evidence of progression after receiving treatment with either an antiestrogen or an aromatase inhibitor as first-line endocrine therapy for metastatic disease (Patients may not have received more than 1 line of endocrine therapy or any prior chemotherapy for metastatic disease) **OR** presented de novo with metastatic disease and then relapsed after receiving treatment with either an antiestrogen or an aromatase inhibitor as first-line endocrine therapy for metastatic disease (Patients may not have received more than 1 line of endocrine therapy or any prior chemotherapy for metastatic disease); 3) have postmenopausal status; 4) have measurable disease or nonmeasurable bone-only disease; 5) have a performance status (PS) of ≤1 on the Eastern Cooperative Oncology Group (ECOG) scale; 6) have adequate organ function; 7) are female and ≥18 years of age; 8) have discontinued previous localized radiotherapy for palliative purposes or for lytic lesions at risk of fracture at least 2 weeks prior to randomization and recovered from the acute effects of therapy except for residual alopecia or peripheral neuropathy; 9) have given written informed consent prior to any study-specific procedures; 10) are able to swallow capsules; and 11) are reliable, willing to be available for the duration of the study, and willing to follow study procedures.

Patients will be excluded from the study if they meet any of the following criteria: 12) have visceral crisis, lymphangitic spread, or leptomeningeal carcinomatosis; 13) have inflammatory breast cancer; 14) have clinical evidence or a history of central nervous system (CNS) metastasis; 15) are currently receiving or have previously received chemotherapy for locoregionally recurrent or metastatic breast cancer; 16) have received prior treatment with everolimus or fulvestrant (for Cohort B only); 17) have received prior treatment with any CDK4 and CDK6 inhibitor; 18) have initiated bisphosphonates or approved RANK ligand (RANK-L) targeted agents <7 days prior to randomization; 19) are currently enrolled in a clinical trial involving an investigational product (IP) or non-approved use of a drug or device (other than the IP/device used in this study), or concurrently enrolled in any other type of medical research judged not to be scientifically or medically compatible with this study; 20) have received treatment with a drug that has not received regulatory approval for any indication within 14 or 21 days of randomization for a nonmyelosuppressive or myelosuppressive agent, respectively; 21) have had major surgery within 14 days prior to randomization to allow for post-operative healing of the surgical wound and site(s); 22) have received recent live attenuated vaccines such as yellow fever vaccine; 23) have serious preexisting medical conditions that, in the judgment of the investigator, would preclude participation in this study; 24) have a personal history within the last 12 months of any of the following conditions: syncope of cardiovascular etiology, ventricular tachycardia, ventricular fibrillation, or sudden cardiac arrest; 25) have a history of any other cancer, unless in complete remission with no therapy for a minimum of 3 years; 26) have received an autologous or allogeneic stem-cell transplant; and 27) have clinical evidence of active bacterial or fungal infection or active viral infection that, in the judgment of the investigator, would preclude participation in this study

**Test Product, Dosage, and Mode of Administration:** Abemaciclib or placebo will be supplied as capsules administered orally, 150 mg every 12 hours (Q12H) on Days 1 to 28 of a 28-day cycle. For patients in Cohort A, either 1 mg anastrozole or 2.5 mg letrozole will be administered orally every 24 hours (Q24H) on Day 1 to 28 of a 28-day cycle. For patients in Cohort B, fulvestrant will be administered 500 mg intramuscularly into the buttocks slowly (1 to 2 minutes per injection) as two 250-mg injections, one in each buttock, on Days 1 and 15 of Cycle 1, then on Day 1 of Cycle 2 and beyond.

**Planned Duration of Treatment:**

Treatment period: until disease progression or other discontinuation criteria are fulfilled.

Short-term follow-up (postdiscontinuation): 30 days ( $\pm$  7 days)

Long-term follow-up (postdiscontinuation): until death

**Criteria for Evaluation:**

Efficacy:

- PFS
- OS
- OS rate at 1 and 2 years
- Objective response rate (Response Evaluation Criteria in Solid Tumors [RECIST] v1.1)
- DoR (RECIST v1.1)
- DCR (RECIST v1.1)
- CBR (RECIST v1.1)

Safety: Adverse events using National Cancer Institute (NCI) Common Terminology Criteria for Adverse Events (CTCAE) Version 4.0 and Medical Dictionary for Regulatory Activities (MedDRA)

Health Outcomes:

- EORTC QLQ-C30: describe target tumor symptom changes
- mBPI-SF: proportion of patients with “worst pain” increase of 2 points or more at any time on-therapy, compared to baseline

Bioanalytical: Plasma concentrations of abemaciclib and its major metabolites will be determined using a validated liquid chromatography/tandem mass spectrometry (LC-MS/MS) method. Plasma concentrations of anastrozole, letrozole, and fulvestrant will also be determined using a validated LC-MS/MS method.

Pharmacokinetics/ Pharmacodynamics: Population PK and/or pharmacodynamic parameters for abemaciclib and abemaciclib metabolites, letrozole, anastrozole, or fulvestrant.

Exploratory:

- to compare the combination treatment of abemaciclib and NSAI therapy versus placebo plus NSAI therapy, and to compare the combination treatment of abemaciclib and fulvestrant therapy versus placebo plus fulvestrant therapy with respect to change in pain burden using the mBPI-sf
- to explore potential biomarkers related to the mechanism of action of abemaciclib, NSAI, fulvestrant, the cell cycle, and/or the pathogenesis of breast cancer, and to correlate potential biomarkers to clinical outcomes
- to explore if change in tumor size is associated with PFS and OS.

**Statistical Methods:**

Statistical: The primary objective of this study is to compare treatment with abemaciclib plus NSAI therapy versus placebo plus NSAI therapy with respect to PFS in postmenopausal women with HR+, HER2- locoregionally recurrent or metastatic breast cancer. A key secondary objective of this study is to evaluate abemaciclib plus fulvestrant versus placebo plus fulvestrant in terms of PFS for women with HR+, HER2- locoregionally recurrent or metastatic breast cancer.

The study will enroll approximately 450 patients in total, with 300 patients in Cohort A and 150 patients in Cohort B. The initiation of enrollment for patients in Cohort B will be triggered later according to Lilly global strategy.

The primary PFS analysis will be performed after approximately 170 PFS events in Cohort A have occurred (ie, a 43% censoring rate). Assuming a hazard ratio of 0.626, this sample size yields at least 81.4% statistical power to detect superiority of the abemaciclib plus NSAI arm over the placebo plus NSAI arm with the use of a 1-sided log-rank test and a type I error of 0.025.

An interim analysis will be conducted on Cohort A when 119 PFS events have been observed. If positive, an interim of Cohort B will also be conducted on the same cutoff. If patients in Cohort A continue being followed for PFS until final analysis, the final analysis of Cohort B will be conducted at the same time of Cohort A final analysis. If Cohort A stops early at interim due to efficacy, the final analysis of Cohort B may be conducted after approximately 105 PFS events have been observed in Cohort B.

Efficacy:

For both Cohort A and Cohort B, the PFS analyses to test the superiority of abemaciclib to placebo in improving PFS will use the log-rank test stratified by stratification variables. Additional analyses will be performed using the Kaplan-Meier method to estimate the PFS and OS curves and rates, and the Cox proportional hazard model will be used to estimate the PFS and OS hazard ratios and corresponding 95% confidence interval.

Safety:

All safety summaries and analyses will be based on the Safety Population. Patients will be grouped according to treatment received in Cycle 1.

Health Outcomes:

Change from baseline in symptom burden will be analyzed descriptively. Treatment arms in each cohort will be compared using a repeated measures model, where appropriate.

Pharmacokinetics/ Pharmacodynamics:

Pharmacokinetic parameters (clearance, area under the plasma concentration versus time curve [AUC], volume of distribution, and half-lives) and inter-individual PK variability for abemaciclib in plasma and pharmacodynamic data (such as neutrophil, lymphocytes, or platelet counts in blood) will be computed using nonlinear mixed effect modeling implemented in NONMEM.

### 3. Table of Contents

## A Randomized, Double-Blind, Placebo-Controlled, Phase 3 Study to Compare NSAI (Anastrozole or Letrozole) plus Abemaciclib, a CDK4 and CDK6 Inhibitor, or plus Placebo, and to Compare Fulvestrant plus Abemaciclib or plus Placebo in Postmenopausal Women with Hormone Receptor-Positive, HER2-Negative Locoregionally Recurrent or Metastatic Breast Cancer

Section	Page
1. Protocol I3Y-CR-JPBQ(e) A Randomized, Double-Blind, Placebo-Controlled, Phase 3 Study to Compare NSAI (Anastrozole or Letrozole) plus Abemaciclib, a CDK4 and CDK6 Inhibitor, or plus Placebo, and to Compare Fulvestrant plus Abemaciclib or plus Placebo in Postmenopausal Women with Hormone Receptor-Positive, HER2-Negative Locoregionally Recurrent or Metastatic Breast Cancer.....	1
2. Synopsis .....	2
3. Table of Contents.....	7
4. Abbreviations and Definitions.....	14
5. Introduction .....	20
6. Objectives.....	23
6.1. Primary Objective .....	23
6.2. Secondary Objectives.....	23
6.3. Exploratory Objectives.....	23
7. Study Population.....	24
7.1. Inclusion Criteria.....	24
7.2. Exclusion Criteria .....	27
7.3. Discontinuation.....	28
7.3.1. Discontinuation of Inadvertently Enrolled Patients.....	28
7.3.2. Discontinuation of Study Drug(s).....	28
7.3.3. Discontinuation from the Study.....	29
7.3.4. Patients Who Are Lost to Follow-Up.....	29
7.3.5. Discontinuation of Study Sites .....	29
7.3.6. Discontinuation of the Study .....	30
8. Investigational Plan.....	31
8.1. Summary of Study Design.....	31



8.1.1.	Study Completion and End of Trial .....	33
8.1.2.	Continued Access Period.....	34
8.2.	Discussion of Design and Control .....	35
9.	Treatment.....	36
9.1.	Treatments Administered .....	36
9.2.	Materials and Supplies .....	38
9.3.	Method of Assignment to Treatment .....	38
9.4.	Selection and Timing of Doses.....	39
9.4.1.	Special Treatment Considerations .....	39
9.4.1.1.	Dose Adjustments and Delays .....	39
9.4.1.1.1.	Dose Adjustments.....	41
9.4.1.1.1.1.	Blinded Study Drug .....	41
9.4.1.1.1.2.	NSAI/Fulvestrant.....	42
9.4.1.1.2.	Dose Suspension (within a Cycle) and Cycle Delay .....	42
9.4.1.1.3.	Hematologic Toxicity .....	43
9.4.1.1.4.	Nonhematologic Toxicity.....	43
9.4.1.1.4.1.	Diarrhea.....	44
9.4.1.1.4.2.	Hepatic Toxicity .....	44
9.5.	Blinding.....	44
9.5.1.	Unblinding at Interim Analyses.....	45
9.5.2.	Emergency Unblinding .....	45
9.5.3.	Inadvertent Unblinding .....	45
9.6.	Concomitant Therapy.....	45
9.6.1.	Surgery and/or Radiotherapy for Locoregionally Recurrent Breast Cancer.....	46
9.6.2.	Radiotherapy.....	46
9.6.3.	Supportive Care .....	46
9.6.4.	Growth Factor.....	47
9.6.5.	Supportive Management for Diarrhea.....	47
9.6.6.	Bisphosphonates and RANK-L Targeted Agents.....	47
9.7.	Treatment Compliance .....	48
9.7.1.	Patient Diaries.....	48
10.	Efficacy, Health Outcome/Quality of Life Measures, Safety Evaluations, Sample Collection and Testing, and Appropriateness of Measurements.....	49
10.1.	Efficacy Measures.....	49
10.1.1.	Efficacy Assessments at Baseline and during Study Treatment.....	49

10.1.2.	Efficacy Assessments during the Study Period Postdiscontinuation Follow-Up .....	50
10.1.3.	Primary Efficacy Measure .....	50
10.1.4.	Secondary Efficacy Measures .....	51
10.1.5.	Exploratory Measures .....	52
10.2.	Health Outcome/Quality of Life Measures .....	53
10.2.1.	Patient-Reported Outcomes .....	53
10.2.1.1.	Health-Related Quality of Life .....	53
10.2.1.2.	Pain Intensity .....	54
10.2.2.	Resource Utilization .....	54
10.3.	Safety Evaluations .....	54
10.3.1.	Adverse Events .....	55
10.3.1.1.	Serious Adverse Events .....	56
10.3.1.2.	Suspected Unexpected Serious Adverse Reactions .....	57
10.3.2.	Other Safety Measures .....	58
10.3.2.1.	Electrocardiograms .....	58
10.3.3.	Safety Monitoring .....	58
10.3.3.1.	Special Hepatic Safety Data Collection .....	58
10.3.3.2.	Renal Function .....	59
10.3.3.3.	Venous Thromboembolic Events .....	59
10.3.4.	Complaint Handling .....	59
10.4.	Sample Collection and Testing .....	60
10.4.1.	Samples for Study Qualification and Health Monitoring .....	60
10.4.2.	Samples for Biomarkers .....	60
10.4.2.1.	Whole Blood Sample for Pharmacogenetic Evaluations .....	61
10.4.2.2.	Plasma Samples for Exploratory Biomarker Evaluations .....	61
10.4.3.	Samples for Drug Concentration Measurements Pharmacokinetics .....	61
10.5.	Appropriateness of Measurements .....	62
11.	Data Quality Assurance .....	63
11.1.	Data Capture System .....	63
12.	Sample Size and Statistical Methods .....	64
12.1.	Determination of Sample Size .....	64
12.2.	Statistical and Analytical Plans .....	65
12.2.1.	General Considerations .....	65
12.2.2.	Patient Disposition .....	65
12.2.3.	Patient Characteristics .....	66
12.2.4.	Concomitant Therapy .....	66

12.2.4.1. Postdiscontinuation Therapy.....	66
12.2.5. Treatment Compliance .....	66
12.2.6. Primary Outcome and Methodology.....	67
12.2.7. Secondary Outcomes and Methodology .....	68
12.2.7.1. Progression-Free Survival in Cohort B.....	68
12.2.7.2. Overall Survival .....	69
12.2.7.3. Objective Response Rate, Disease Control Rate, Clinical Benefit Rate, and Duration of Response.....	69
12.2.8. Sensitivity Analysis.....	69
12.2.9. Pharmacokinetic and Pharmacodynamic Analyses .....	69
12.2.10. Biomarker Analyses.....	70
12.2.11. Health Outcome/Quality-of-Life Analyses .....	70
12.2.11.1. Health-Related Quality of Life.....	70
12.2.11.2. Pain Intensity.....	70
12.2.11.3. Resource Utilization .....	71
12.2.12. Safety Analyses.....	71
12.2.13. Subgroup Analyses .....	72
12.2.14. Interim Analysis and Other Planned Analyses .....	72
13. Informed Consent, Ethical Review, and Regulatory Considerations .....	74
13.1. Informed Consent.....	74
13.2. Ethical Review.....	74
13.3. Regulatory Considerations .....	74
13.3.1. Investigator Information.....	75
13.3.2. Protocol Signatures .....	75
13.3.3. Final Report Signature .....	75
14. References .....	76

**List of Tables**

<b>Table</b>		<b>Page</b>
Table JPBQ.9.1.	Treatment Regimens/Dosing Schedule .....	37
Table JPBQ.9.2.	Toxicity Dose Adjustments and Delays of Blinded Study Drug for Study JPBQ.....	40
Table JPBQ.9.3.	Dose Adjustments for Abemaciclib .....	41
Table JPBQ.10.1.	Other Secondary Efficacy Endpoints .....	52
Table JPBQ.10.2.	Exploratory Measures.....	52
Table JPBQ.10.3.	Adverse Event and Serious Adverse Event Reporting Guidelines .....	55
Table JPBQ.12.1.	Rules for Determining Date of Progression or Censor for Progression-Free Survival.....	67
Table JPBQ.12.2.	Properties of Design for Progression-Free Survival.....	68

**List of Figures**

<b>Figure</b>		<b>Page</b>
Figure JPBQ.8.1.	Illustration of study design.....	31
Figure JPBQ.8.2.	Study period and continued access diagram. ....	34

## List of Attachments

<b>Attachment</b>		<b>Page</b>
Attachment 1.	Protocol JPBQ Study Schedule .....	78
Attachment 2.	Protocol JPBQ Clinical Laboratory Tests.....	85
Attachment 3.	Protocol JPBQ Hepatic Monitoring Tests for Treatment-Emergent Abnormality .....	86
Attachment 4.	Protocol JPBQ ECOG Performance Status .....	87
Attachment 5.	Protocol JPBQ RECIST Criteria 1.1 .....	88
Attachment 6.	Protocol JPBQ Sampling Summary .....	95
Attachment 7.	Protocol JPBQ Pharmacokinetic Sampling Schedule .....	96
Attachment 8.	Protocol JPBQ Inducers of CYP3A, Strong Inhibitors of CYP3A, or Substrates of CYPs with Narrow Therapeutic Range .....	97
Attachment 9.	Protocol JPBQ CTCAE 4.03 Diarrhea Definition .....	99
Attachment 10.	Protocol JPBQ Amendment (e) Summary A Randomized, Double- Blind, Placebo-Controlled, Phase 3 Study to Compare NSAI (Anastrozole or Letrozole) plus Abemaciclib, a CDK4 and CDK6 Inhibitor, or plus Placebo, and to Compare Fulvestrant plus Abemaciclib or plus Placebo in Postmenopausal Women with Hormone Receptor-Positive, HER2-Negative Locoregionally Recurrent or Metastatic Breast Cancer .....	101

## 4. Abbreviations and Definitions

Term	Definition
<b>AE</b>	adverse event  Any untoward medical occurrence in a patient or clinical investigation subject administered a pharmaceutical product and that does not necessarily have a causal relationship with this treatment. An adverse event can therefore be any unfavorable and unintended sign (including an abnormal laboratory finding), symptom, or disease temporally associated with the use of a medicinal (investigational) product, whether or not related to the medicinal (investigational) product.
<b>ALT</b>	alanine aminotransferase
<b>ANC</b>	absolute neutrophil count
<b>ASCO</b>	American Society of Clinical Oncology
<b>assent</b>	Agreement from a child or other individual who is not legally capable of providing consent, but who can understand the circumstances and risks involved in participating in a study (required by some ERBs).
<b>AST</b>	aspartate aminotransferase
<b>AUC</b>	area under the plasma concentration versus time curve
<b>audit</b>	A systematic and independent examination of the trial-related activities and documents to determine whether the evaluated trial-related activities were conducted, and the data were recorded, analyzed, and accurately reported according to the protocol, applicable standard operating procedures, GCP, and the applicable regulatory requirement(s).
<b>blinding/masking</b>	A procedure in which one or more parties to the trial are kept unaware of the treatment assignment(s). Unless otherwise specified, blinding will remain in effect until final database lock.  A single-blind study is one in which the investigator and/or his staff are aware of the treatment but the patient is not, or vice versa, or when the sponsor is aware of the treatment but the investigator and/his staff and the patient are not.  A double-blind study is one in which neither the patient nor any of the investigator or sponsor staff who are involved in the treatment or clinical evaluation of the patients are aware of the treatment received.
<b>CAP</b>	College of American Pathologists
<b>CBR</b>	clinical benefit rate
<b>CDK4 and CDK6</b>	cyclin-dependent kinases 4 and 6
<b>CI</b>	confidence interval
<b>CNS</b>	central nervous system
<b>collection database</b>	A computer database where clinical trial data are entered and validated.

<b>complaint</b>	A complaint is any written, electronic, or oral communication that alleges deficiencies related to the identity, quality, purity, durability, reliability, safety or effectiveness, or performance of a drug or drug delivery system.
<b>compliance</b>	Adherence to all the trial-related requirements, GCP requirements, and the applicable regulatory requirements.
<b>continued access period</b>	The period between study completion and end of trial during which patients on study therapy who continue to experience clinical benefit and no undue risks may continue to receive study therapy until one of the criteria for discontinuation is met.
<b>CR</b>	complete response
<b>CRF/eCRF</b>	case report form/electronic case report form  Sometimes referred to as clinical report form: A printed or electronic form for recording study participants' data during a clinical study, as required by the protocol.
<b>CRP</b>	clinical research physician  Individual responsible for the medical conduct of the study. Responsibilities of the CRP may be performed by a physician, clinical research scientist, global safety physician, or other medical officer.
<b>CSR</b>	clinical study report
<b>CT</b>	computed tomography
<b>CTCAE</b>	Common Terminology Criteria for Adverse Events
<b>CTS</b>	change in tumor size  A measure of tumor dynamics from which tumor response is derived. Tumor size is the sum of tumor measurements across all target tumors at a given evaluation (RECIST criteria).
<b>CYP</b>	cytochrome P450
<b>DCR</b>	disease control rate
<b>DFI</b>	disease free interval (DFI) is defined as the period of time between the completion of adjuvant endocrine therapy and disease recurrence for those patients who received adjuvant endocrine therapy
<b>DMC</b>	Data Monitoring Committee
<b>DoR</b>	duration of response
<b>ECG</b>	electrocardiogram
<b>ECOG</b>	Eastern Cooperative Oncology Group
<b>EDTA</b>	ethylenediamine tetraacetic acid



<b>end of trial</b>	The end of trial occurs after study completion and after the last patient has discontinued study treatment and completed any applicable continued access follow-up.
<b>enroll</b>	The act of assigning a patient to a treatment. Patients who are enrolled in the trial are those who have been assigned to a treatment.
<b>enter</b>	Patients entered into a trial are those who sign the informed consent form directly or through their legally acceptable representatives.
<b>EORTC</b>	European Organization for Research and Treatment of Cancer
<b>EORTC QLQ-C30</b>	European Organization for Research and Treatment of Cancer Quality of Life Questionnaire-Core 30
<b>ER</b>	estrogen receptor
<b>ER+</b>	estrogen receptor-positive
<b>ERB</b>	ethical review board  A board or committee (institutional, regional, or national) composed of medical and nonmedical members whose responsibility is to verify that the safety, welfare, and human rights of the patients participating in a clinical trial are protected.
<b>FSH</b>	follicle-stimulating hormone
<b>GCP</b>	good clinical practice
<b>HER2</b>	human epidermal growth factor receptor 2
<b>HER2-</b>	human epidermal growth factor receptor 2-negative
<b>HIV</b>	human immunodeficiency virus
<b>HR</b>	hormone receptor
<b>HR+</b>	hormone receptor-positive
<b>IB</b>	Investigator's Brochure
<b>ICF</b>	informed consent form
<b>ICH</b>	International Conference on Harmonisation
<b>IHC</b>	immunohistochemistry
<b>Informed consent</b>	A process by which a patient voluntarily confirms his or her willingness to participate in a particular trial, after having been informed of all aspects of the trial that are relevant to the patient's decision to participate. Informed consent is documented by means of a written, signed, and dated informed consent form.
<b>interim analysis</b>	An interim analysis is an analysis of clinical trial data, separated into treatment groups, that is conducted before the final reporting database is created/locked.

<b>investigational product (IP)</b>	A pharmaceutical form of an active ingredient or placebo being tested or used as a reference in a clinical trial.
<b>investigator</b>	A person responsible for the conduct of the clinical trial at a trial site. If a trial is conducted by a team of individuals at a trial site, the investigator is the responsible leader of the team and may be called the principal investigator.
<b>IRC</b>	Internal Review Committee
<b>ITT</b>	intention-to-treat  The principle that asserts that the effect of a treatment policy can be best assessed by evaluating on the basis of the intention to treat a patient (that is, the planned treatment regimen) rather than the actual treatment given. It has the consequence that patients allocated to a treatment group should be followed up, assessed, and analyzed as members of that group irrespective of their compliance to the planned course of treatment.
<b>IV</b>	intravenous
<b>IWRS</b>	interactive web response system
<b>LC-MS/MS</b>	liquid chromatography/tandem mass spectrometry
<b>legal representative</b>	An individual, judicial, or other body authorized under applicable law to consent on behalf of a prospective patient to the patient's participation in the clinical study.
<b>Lilly Safety System</b>	Global safety database that tracks and reports serious adverse and spontaneous events occurring while using a drug/drug delivery system.
<b>LLT</b>	Lower Level Term
<b>mBC</b>	metastatic breast cancer
<b>mBPI-sf</b>	modified Brief Pain Inventory short form
<b>MedDRA</b>	Medical Dictionary for Regulatory Activities
<b>MRI</b>	magnetic resonance imaging
<b>mRNA</b>	messenger ribonucleic acid
<b>NCI</b>	National Cancer Institute
<b>NSAI</b>	nonsteroidal aromatase inhibitor
<b>OS</b>	overall survival
<b>patient</b>	A study participant who has the disease or condition for which the investigational product is targeted.
<b>PD</b>	progressive disease
<b>PET</b>	positron emission tomography

<b>PFS</b>	progression-free survival
<b>PgR</b>	progesterone receptor
<b>PK</b>	pharmacokinetic(s)
<b>PR</b>	partial response
<b>PRO</b>	patient-reported outcome
<b>PS</b>	performance status
<b>PT</b>	Preferred Term
<b>Q12H</b>	every 12 hours
<b>Q24H</b>	every 24 hours
<b>QTc</b>	corrected QT interval
<b>randomize</b>	the process of assigning patients to an experimental group on a random basis
<b>RANK-L</b>	RANK ligand
<b>Rb</b>	retinoblastoma
<b>RECIST</b>	Response Evaluation Criteria in Solid Tumors
<b>reporting database</b>	A point-in-time copy of the collection database. The final reporting database is used to produce the analyses and output reports for interim or final analyses of data.
<b>re-screen</b>	to screen a patient who was previously declared a screen failure for the same study
<b>SAE</b>	serious adverse event
<b>SAP</b>	Statistical Analysis Plan
<b>screen</b>	The act of determining if an individual meets minimum requirements to become part of a pool of potential candidates for participation in a clinical study
<b>screen failure</b>	patient who does not meet one or more criteria required for participation in a trial
<b>SD</b>	stable disease
<b>SMD</b>	Senior Management Designee
<b>SOC</b>	System Organ Class
<b>study completion</b>	This study will be considered complete, following the last required PFS event from Cohort A or Cohort B, whichever is longer, as determined by Lilly, when all of the required short-term follow-up assessment is completed.
<b>SUSAR</b>	suspected unexpected serious adverse reaction

<b>TEAE</b>	treatment-emergent adverse event Any untoward medical occurrence that either occurs or worsens at any time after treatment baseline and that does not necessarily have to have a causal relationship with this treatment.
<b>TPO</b>	third-party organization
<b>ULN</b>	upper limit of normal
<b>VTE</b>	venous thromboembolic event

---

# **A Randomized, Double-Blind, Placebo-Controlled, Phase 3 Study to Compare NSAI (Anastrozole or Letrozole) plus Abemaciclib, a CDK4 and CDK6 Inhibitor, or plus Placebo, and to Compare Fulvestrant plus Abemaciclib or plus Placebo in Postmenopausal Women with Hormone Receptor-Positive, HER2-Negative Locoregionally Recurrent or Metastatic Breast Cancer**

## **5. Introduction**

Breast cancer is one of the most common cancers in women. In 2012, there were approximately 1.7 million new cases of breast cancer worldwide; since 2008, the worldwide incidence of breast cancer has increased by more than 20% and mortality has increased by 14% (Bray et al. 2013; Ferlay et al. [WWW]). While early-stage disease is treatable, patients with metastatic breast cancer (mBC) have a median overall survival (OS) of only 2 to 3 years (Cardoso et al. 2012). The treatment for women diagnosed with hormone receptor-positive (HR+) mBC includes endocrine therapy. In postmenopausal women, aromatase inhibitors (including anastrozole and letrozole) are recommended for the initial treatment of mBC, if not used in the adjuvant setting or if discontinued for at least 12 months (Cardoso et al. 2012). However, *de novo* or acquired resistance to adjuvant endocrine therapy and mBC remains an important clinical challenge.

Cyclin D1 interacts with cyclin-dependent kinases 4 and 6 (hereafter CDK4 and CDK6) in an active protein complex that promotes cell proliferation (Velasco-Velazquez et al. 2011). Many HR+ breast cancers demonstrate an intact retinoblastoma (Rb) tumor suppressive function; however, overexpression of cyclin D1 protein by oncogenic signaling occurs in approximately 30% to 50% of cancers. Cyclin D1 is regarded as the most frequently overexpressed gene in primary breast cancer, with amplification of the encoding gene, CCND1, occurring in approximately 15% of breast cancers (Casimiro et al. 2014). Therefore, CDK4 and CDK6 represent a potential therapeutic target for HR+ breast cancer. Consequently, further evaluation of CDK4 and CDK6 inhibitors to improve clinical outcomes for women with HR+ breast cancer is warranted.

During the cell cycle, the G1 restriction point controls entry into S phase and is essential for proper regulation of cell proliferation (Sherr 1996; Ortega et al. 2002). Cyclin-dependent kinase 4 and CDK6 participate in a complex with the D-type cyclins to initiate progression through the G1 restriction point. The CDK4 and CDK6 – cyclin D1 complex regulates the G1 restriction point through phosphorylation and inactivation of the Rb tumor suppressor protein, thereby promoting S phase entry. Alterations in this pathway occur frequently in human cancers and involve: 1) loss of functional cyclin-dependent kinase inhibitors through deletion or epigenetic silencing; 2) activating mutations and/or overexpression of CDK4 and CDK6 or the D-type cyclins; and 3) loss of functional Rb through mutation or deletion. Except for tumors with functional loss of Rb, which functions downstream of the CDK4 and CDK6 – cyclin D1

complex, most cancers are potentially sensitive to pharmacologic inhibition of CDK4 and CDK6. From a therapeutic standpoint, the goal of inhibiting CDK4 and CDK6 with a small molecule is to prevent cell cycle progression through the G1 restriction point, thus arresting tumor growth.

Abemaciclib represents a selective and potent small molecule inhibitor of CDK4 and CDK6 with acceptable physical characteristics, pharmacokinetic (PK) properties, and safety profile in nonclinical species. There may be important opportunities to tailor therapy with abemaciclib for patients with breast cancer. Specifically, studies with abemaciclib indicate differential sensitivity to CDK4 and CDK6 inhibition based on histological and genetic characteristics. Growth inhibition in vitro across a diverse panel of 46 breast cancer cell lines, representing the known molecular subgroups of breast cancer, indicates that sensitivity to CDK4 and CDK6 inhibition is greater in ER+ breast cancers with luminal histology. In accordance with the known biology of CDK4 and CDK6, the results also indicate that many of these sensitive cell lines are also characterized as having amplification of CCND1, which is the gene that encodes cyclin D1. These results are consistent with previous studies that demonstrate that effective induction of G1 cell cycle arrest by abemaciclib is dependent upon the presence of Rb.

Findings from the Phase 1 Study I3Y-MC-JPBA (JPBA) indicate that the abemaciclib single-agent maximum tolerated dose of 200 mg administered orally every 12 hours (Q12H) demonstrates an acceptable safety profile. Abemaciclib has demonstrated evidence of clinical activity in women with mBC at doses of both 150 mg and 200 mg Q12H. Additionally, preliminary analysis of PK data from Study JPBA for abemaciclib as a single agent at 150 mg and 200 mg Q12H indicates that the range of steady-state exposures is comparable for the 2 doses. In Study JPBA, 47 patients with a median of 7 prior systemic regimens received therapy with abemaciclib. In the mBC cohort, the most common treatment-emergent adverse events (TEAEs) possibly related to study drug included diarrhea, nausea, fatigue, neutropenia, and vomiting. Among 36 patients with HR+ mBC receiving abemaciclib, the median progression-free survival (PFS) was 8.8 months and there were 12 confirmed partial responses (PRs), for an objective response rate of 33.3%. In the same study, the combination of abemaciclib plus fulvestrant was also evaluated and demonstrated an acceptable safety profile in 19 women with HR+ mBC. In addition, 4 confirmed PRs were observed in these 19 patients. Safety and tolerability of abemaciclib in combination with endocrine therapies (including anastrozole and letrozole) are being further evaluated in patients with HR+, human epidermal growth factor receptor 2-negative (HER2-) mBC, in the ongoing Phase 1b Study I3Y-MC-JPBH (JPBH).

To further confirm the safety and efficacy of abemaciclib in combination with current standard endocrine therapies (either nonsteroidal aromatase inhibitors [NSAIs] or fulvestrant) in HR+, HER2- breast cancer, 2 randomized, double-blind, placebo-controlled, Phase 3 studies, Studies I3Y-MC-JPBM and I3Y-MC-JPBL, are being conducted globally. Along with these 2 studies, this randomized, double-blind, placebo-controlled Phase 3 study, Study I3Y-CR-JPBQ (JPBQ), will evaluate the safety and efficacy of abemaciclib in combination with both endocrine therapies in mainly east Asian patients with HR+, HER2- locoregionally recurrent or metastatic breast cancer and postmenopausal status.

More information about the known and expected benefits and risks and reasonably anticipated adverse events (AEs) of abemaciclib may be found in the Investigator's Brochure (IB). Information on AEs expected to be related to the study drug may be found in Section 7 (Development Core Safety Information) of the IB. Information on serious adverse events (SAEs) expected in the study population independent of drug exposure and that will be assessed by the sponsor in aggregate, periodically during the course of the study, may be found in Section 6 (Effects in Humans) of the IB.

More detailed information about the known and expected benefits and risks of abemaciclib may be found in the following: Patient Information Leaflet, Package Insert, and Summary of Product Characteristics.

## 6. Objectives

### 6.1. Primary Objective

The primary objective of this study is to compare treatment with abemaciclib plus NSAID (anastrozole or letrozole) therapy versus placebo plus NSAID therapy with respect to PFS in postmenopausal women with HR+, HER2- locoregionally recurrent or metastatic breast cancer.

### 6.2. Secondary Objectives

The key secondary objective of this study is to compare treatment with abemaciclib plus fulvestrant therapy versus placebo plus fulvestrant therapy with respect to PFS for postmenopausal women with HR+, HER2- locoregionally recurrent or metastatic breast cancer.

Other secondary objectives of this study are to compare the combination treatment of abemaciclib and NSAID therapy versus placebo plus NSAID therapy, and to compare the combination treatment of abemaciclib and fulvestrant therapy versus placebo plus fulvestrant therapy with respect to the following:

- OS
- OS rate at 1 and 2 years
- objective response rate (complete response [CR] + PR)
- duration of response (DoR; CR + PR)
- disease control rate (DCR; CR + PR + stable disease [SD])
- clinical benefit rate (CBR; CR + PR + SD  $\geq$  6 months)
- safety and tolerability
- change in symptom burden from baseline using the European Organization for Research and Treatment of Cancer Quality of Life Questionnaire-Core 30 (EORTC QLQ-C30)
- PK of abemaciclib, its metabolites, NSAID, and fulvestrant.

### 6.3. Exploratory Objectives

The exploratory objectives of this study are:

- to compare the combination treatment of abemaciclib and NSAID therapy versus placebo plus NSAID therapy, and to compare the combination treatment of abemaciclib and fulvestrant therapy versus placebo plus fulvestrant therapy with respect to change in pain burden using the modified Brief Pain Inventory short form (mBPI-sf).
- to explore potential biomarkers related to the mechanism of action of abemaciclib, NSAID, fulvestrant, the cell cycle, and/or the pathogenesis of breast cancer, and to correlate potential biomarkers to clinical outcomes.
- to explore if change in tumor size (CTS) is associated with PFS and OS.



## 7. Study Population

The study includes 2 cohorts. Patients meeting Inclusion Criterion 2a (Section 7.1) will be enrolled in Cohort A and patients meeting Inclusion Criterion 2b (Section 7.1) will be enrolled in Cohort B.

Re-screening of individuals who do not meet the criteria for participation in this study is not permitted.

Study participants should be instructed not to donate blood or blood products during the study or for 9 months following the last dose of fulvestrant or 2 weeks following the last dose of blinded study drug, whichever is longer.

Prospective approval of protocol deviations to recruitment and enrollment criteria (also known as protocol waivers or exemptions) is not permitted.

### 7.1. Inclusion Criteria

Patients are eligible to be included in the study only if they meet **all** of the following criteria:

- [1] have a diagnosis of HR+, HER2- breast cancer. Although not required as a protocol procedure, metastatic disease should be considered for biopsy whenever possible to reassess hormone receptor (HR) and human epidermal growth factor receptor 2 (HER2) status if clinically indicated.
  - To fulfill the requirement for HR+ disease, a breast cancer must express, by immunohistochemistry (IHC), at least 1 of the HRs (estrogen receptor [ER], progesterone receptor [PgR]) as defined in the relevant American Society of Clinical Oncology (ASCO)/College of American Pathologists (CAP) guidelines (Hammond et al. 2010).
  - To fulfill the requirement of HER2- disease, a breast cancer must not demonstrate, at initial diagnosis or upon subsequent biopsy, overexpression of HER2 by either IHC or in-situ hybridization as defined in the relevant ASCO/CAP guidelines (Wolff et al. 2013).
- [2] meet either Inclusion Criterion (2a) or Inclusion Criterion (2b). Patients meeting Inclusion Criterion 2a will be enrolled in Cohort A and patients meeting Inclusion Criterion 2b will be enrolled in Cohort B.
  - (2a) have locoregionally recurrent disease not amenable to resection or radiation therapy with curative intent or metastatic disease

- relapsed with radiologic evidence of progression more than 1 year from completion of/or with no adjuvant endocrine therapy and have received no prior endocrine therapy for locoregionally recurrent or metastatic disease (Note: prior adjuvant endocrine therapy for localized disease may have included, but is not limited to, anti-estrogens or aromatase inhibitors. In addition, a patient may be enrolled if she has received  $\leq 2$  weeks of NSAI in this disease setting immediately preceding screening and agrees to discontinue NSAI until study treatment initiation.)

OR

- relapsed with radiologic evidence of progression less than 1 year from completion of or while receiving adjuvant endocrine therapy (except for letrozole or anastrozole) and have received no prior endocrine therapy for locoregionally recurrent or metastatic disease.
- OR
- presented de novo mBC and not received any prior endocrine therapy.

(2b) have locoregionally recurrent disease not amenable to resection or radiation therapy with curative intent or metastatic disease

- relapsed with radiologic evidence of progression while receiving neoadjuvant or adjuvant letrozole or anastrozole, with no subsequent endocrine therapy received following progression

OR

- relapsed with radiologic evidence of progression within 1 year from completion of adjuvant letrozole or anastrozole, with no subsequent endocrine therapy received following progression

OR

- relapsed with radiologic evidence of progression more than 1 year from completion of adjuvant endocrine therapy and then subsequently relapsed with radiologic evidence of progression after receiving treatment with either an antiestrogen or an aromatase inhibitor as first-line endocrine therapy for metastatic disease. Patients may not have received more than 1 line of endocrine therapy or any prior chemotherapy for metastatic disease

OR

- presented de novo with metastatic disease and then relapsed with radiologic evidence of progression after receiving treatment with either an antiestrogen or an aromatase inhibitor as first-line endocrine therapy for metastatic disease. Patients may not have received more than 1 line of endocrine therapy or any prior chemotherapy for metastatic disease.
- [3] have postmenopausal status defined as meeting at least 1 of the following:
- prior bilateral oophorectomy
  - age  $\geq 60$  years
  - age  $< 60$  years and amenorrheic for at least 12 months (in the absence of chemotherapy, tamoxifen, toremifene, or ovarian suppression) and follicle-stimulating hormone (FSH) and estradiol levels in the postmenopausal range
- [4] have 1 of the following, as defined by the Response Evaluation Criteria in Solid Tumors (RECIST) v1.1 (Eisenhauer et al. 2009; see [Attachment 5](#)):
- Measurable disease
  - Nonmeasurable bone-only disease. Nonmeasurable bone-only disease may include any of the following: blastic bone lesions, lytic bone lesions without a measurable soft tissue component, or mixed lytic-blastic bone lesions without a measurable soft tissue component.
- [5] have a performance status (PS) of  $\leq 1$  on the Eastern Cooperative Oncology (ECOG) scale (see [Attachment 4](#))
- [6] have adequate organ function, including:
- hematologic: absolute neutrophil count (ANC)  $\geq 1.5 \times 10^9/L$ , platelets  $\geq 100 \times 10^9/L$ , and hemoglobin  $\geq 8$  g/dL. Patients may receive erythrocyte transfusions to achieve this hemoglobin level at the discretion of the investigator; however, initial study drug treatment must not begin earlier than the day after the erythrocyte transfusion.
  - hepatic: Total bilirubin  $\leq 1.5$  times the upper limit of normal (ULN) and alanine aminotransferase (ALT) and aspartate aminotransferase (AST)  $\leq 3.0$  times ULN (or ALT and AST  $\leq 5$  times ULN if liver metastases are present).
  - renal: serum creatinine  $\leq 1.5$  times ULN.
- [7] are female and  $\geq 18$  years of age
- [8] have discontinued previous localized radiotherapy for palliative purposes or for lytic lesions at risk of fracture at least 2 weeks prior to randomization and recovered from the acute effects of therapy (until the toxicity resolves to either baseline or at least Grade 1) except for residual alopecia or peripheral neuropathy

- [9] have given written informed consent prior to any study-specific procedures
- [10] are able to swallow capsules
- [11] are reliable, willing to be available for the duration of the study, and willing to follow study procedures.

## 7.2. Exclusion Criteria

Patients will be excluded from the study if they meet **any** of the following criteria:

- [12] have visceral crisis, lymphangitic spread, or leptomeningeal carcinomatosis. Visceral crisis is not the mere presence of visceral metastases, but implies severe organ dysfunction as assessed by symptoms and signs, laboratory studies, and rapid progression of the disease
- [13] have inflammatory breast cancer
- [14] have clinical evidence or a history of central nervous system (CNS) metastasis. Screening test is not required for enrollment.
- [15] are currently receiving or have previously received chemotherapy for locoregionally recurrent or metastatic breast cancer. (Note: Patients may be enrolled if they received prior [neo]adjuvant chemotherapy for localized disease.)
- [16] have received prior treatment with everolimus or fulvestrant (for Cohort B only)
- [17] have received prior treatment with any CDK4 and CDK6 inhibitor (or participated in any CDK4 and CDK6 inhibitor clinical trial for which treatment assignment is still blinded)
- [18] have initiated bisphosphonates or approved RANK ligand (RANK-L) targeted agents <7 days prior to randomization
- [19] are currently enrolled in a clinical trial involving an investigational product (IP) or non-approved use of a drug or device (other than the IP/device used in this study), or concurrently enrolled in any other type of medical research judged not to be scientifically or medically compatible with this study. If a patient is currently enrolled in a clinical trial involving non-approved use of a device, then agreement with the investigator and Eli Lilly and Company (Lilly) clinical research physician (CRP) is required to establish eligibility.
- [20] have received treatment with a drug that has not received regulatory approval for any indication within 14 or 21 days of randomization for a nonmyelosuppressive or myelosuppressive agent, respectively
- [21] have had major surgery within 14 days prior to randomization to allow for post-operative healing of the surgical wound and site(s)
- [22] have received recent (within 28 days prior to randomization) live attenuated vaccines such as yellow fever vaccine.

- [23] have serious preexisting medical conditions that, in the judgment of the investigator, would preclude participation in this study (eg, history of major surgical resection involving the stomach or small bowel, or preexisting Crohn's disease or ulcerative colitis)
- [24] have a personal history within the last 12 months of any of the following conditions: syncope of cardiovascular etiology, ventricular tachycardia, ventricular fibrillation, or sudden cardiac arrest
- [25] have a history of any other cancer (except nonmelanoma skin cancer or carcinoma in-situ of the cervix), unless in complete remission with no therapy for a minimum of 3 years
- [26] have received an autologous or allogeneic stem-cell transplant.
- [27] have clinical evidence of active bacterial or fungal infection or active viral infection that, in the judgment of the investigator, would preclude participation in this study (eg, human immunodeficiency virus [HIV] or viral hepatitis). Screening test is not required for enrollment.

### **7.3. Discontinuation**

The reason for discontinuation and the date of discontinuation will be collected for all patients. All randomized patients who discontinue, regardless of whether or not they received study treatment, will have procedures performed as shown in the Study Schedule ([Attachment 1](#)).

Patients who are discontinued from the study drug early will have follow-up procedures performed as shown in the Study Schedule ([Attachment 1](#)).

If a patient withdraws informed consent, he or she must not be contacted unless he or she has explicitly provided permission and consent. Lilly may continue to use previously collected medical research data prior to the withdrawal consistent with the original authorization.

#### ***7.3.1. Discontinuation of Inadvertently Enrolled Patients***

The criteria for enrollment must be followed explicitly. If the investigator site identifies a patient who did not meet enrollment criteria and who was inadvertently enrolled, the sponsor must be notified. If the sponsor identifies a patient who did not meet enrollment criteria and who was inadvertently enrolled, the investigator site will be notified. A discussion must occur between the sponsor CRP and the investigator to determine whether the patient may continue in the study, with or without study drug. Inadvertently enrolled patients may be maintained in the study and on study drug when the Lilly CRP agrees with the investigator that it is medically appropriate for that patient. The patient may not continue in the study with or without study drug if the Lilly CRP does not agree with the investigator's determination it is medically appropriate for the patient to continue. The investigator must obtain documented approval from the Lilly CRP to allow the inadvertently enrolled patient to continue in the study with or without study drug.

#### ***7.3.2. Discontinuation of Study Drug(s)***

Patients will be discontinued from the study drugs in the following circumstances:

- progressive disease (PD) as defined by RECIST v1.1
- the investigator decides that the patient should be discontinued from study drugs
- the patient or the patient's designee (eg, parents or legal guardian) requests that the patient be withdrawn from study drugs
- the patient is significantly noncompliant with study procedures and/or treatment
- unacceptable toxicity
- the patient has had 2 dose reductions and experiences an AE that would cause a third dose reduction
- the patient, for any reason, requires treatment with another therapeutic agent that has been demonstrated to be effective for treatment of the study indication, discontinuation from study drugs occurs prior to introduction of the new agent
- enrollment in any other clinical trial involving an IP or enrollment in any other type of medical research judged not to be scientifically or medically compatible with this study

If patients discontinue NSAIs/fulvestrant but continue to receive blinded study drug, this will not be considered as discontinuation of study drug.

### **7.3.3. Discontinuation from the Study**

Patients will be discontinued from the study in the following circumstances:

- the investigator decides that the patient should be discontinued from the study
- the patient or the patient's designee (eg, parents or legal guardian) requests that the patient be withdrawn from the study
- Lilly stops the study or stops the patient's participation in the study for medical, safety, regulatory, or other reasons consistent with applicable laws, regulations, and good clinical practice (GCP)

### **7.3.4. Patients Who Are Lost to Follow-Up**

A patient will be considered lost to follow up if he or she repeatedly fails to return for scheduled visits and is unable to be contacted by the study site. Site personnel are expected to make diligent attempts to contact patients who fail to return for a scheduled visit or who the site is otherwise unable to follow.

Site personnel, or an independent third party, will attempt to collect the vital status (ie, alive or dead) for all randomized patients who are lost to follow up, including randomized patients who do not receive study treatment, within legal and ethical boundaries. Site personnel, or an independent third party, may search public sources for vital status information. If the patient's vital status is determined, the vital status will be documented and the patient will not be considered lost to follow up.

Lilly personnel will not be involved in any attempts to collect vital status information.

### **7.3.5. Discontinuation of Study Sites**

Study site participation may be discontinued if Lilly, the investigator, or the ethical review board (ERB) of the study site judges discontinuation of study site participation necessary for medical,

safety, regulatory, ethical, or other reasons consistent with applicable laws, regulations, and GCP.

**7.3.6. *Discontinuation of the Study***

The study will be discontinued if Lilly judges discontinuation of the study necessary for medical, safety, regulatory, ethical, or other reasons consistent with applicable laws, regulations, and GCP.

## 8. Investigational Plan

### 8.1. Summary of Study Design

Study JPBQ is a multicenter, randomized, double-blind, Phase 3 trial for women with HR+, HER2- locoregionally recurrent or metastatic breast cancer.

Figure JPBQ.8.1 illustrates the study design.

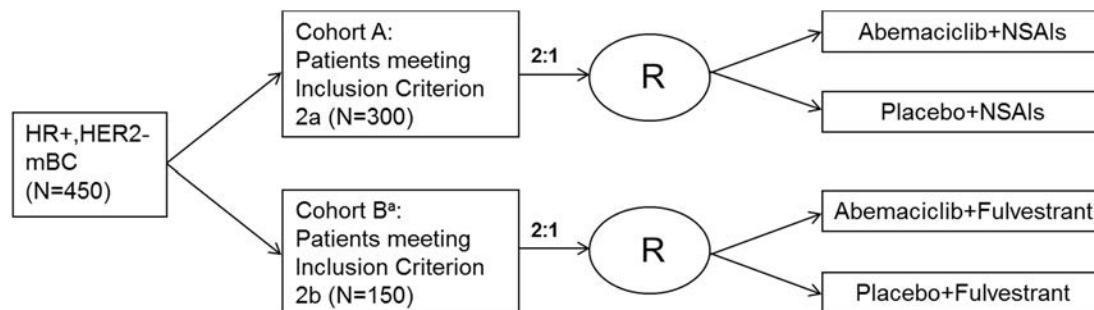

Abbreviations: HER2- = human epidermal growth factor receptor 2-negative; HR+ = hormone receptor-positive; mBC = metastatic breast cancer; N = number of planned patients; NSAID = nonsteroidal aromatase inhibitor; R = randomization

<sup>a</sup> The initiation of enrollment for patients in Cohort B was triggered later according to Lilly global strategy.

**Figure JPBQ.8.1. Illustration of study design.**

The study will consist of 2 patient cohorts:

- Cohort A will include approximately 300 patients with HR+, HER2- locoregionally recurrent or metastatic breast cancer who meet Inclusion Criterion 2a (Section 7.1).
- Cohort B will additionally include approximately 150 patients with HR+, HER2- locoregionally recurrent or metastatic breast cancer who meet Inclusion Criterion 2b (Section 7.1). The initiation of enrollment for patients in Cohort B was triggered later according to Lilly global strategy.

Patients in each cohort will be randomized 2:1 between the experimental and control arms:

- Arm A1: Abemaciclib 150 mg orally Q12H on Days 1 to 28 plus either anastrozole 1 mg or letrozole 2.5 mg orally Q24H of a 28-day cycle
- Arm A2: Placebo orally Q12H on Days 1 to 28 plus either anastrozole 1 mg or letrozole 2.5 mg orally Q24H of a 28-day cycle
- Arm B1: Abemaciclib 150 mg orally Q12H on Days 1 to 28 of a 28-day cycle plus fulvestrant 500 mg intramuscularly on Days 1 and 15 of Cycle 1, then on Day 1 of Cycle 2 and beyond
- Arm B2: Placebo orally Q12H on Days 1 to 28 of a 28-day cycle plus fulvestrant 500 mg intramuscularly on Days 1 and 15 of Cycle 1, then on Day 1 of Cycle 2 and beyond



Patients in Cohort A will be randomized using the following stratification factors: nature of disease (visceral metastases vs. non-visceral metastases) and prior (neo)adjuvant endocrine therapy (prior therapy with disease-free interval > 12 months from completion of treatment vs. prior therapy with disease-free interval ≤ 12 months from completion of treatment vs. no prior endocrine therapy). The presence of visceral metastases refers to lung, liver, pleural, peritoneal, or adrenal gland involvement at the time of randomization.

Patients in Cohort B will be randomized using the following stratification factors: nature of disease (visceral metastases vs. non-visceral metastases) and sensitivity to endocrine therapy (primary resistance vs. secondary resistance). The presence of visceral metastases refers to lung, liver, pleural, or peritoneal, or adrenal gland involvement at the time of randomization. Primary clinical resistance to endocrine therapy is defined as follows: 1) for endocrine therapy in the adjuvant setting, recurrence within the first 2 years of adjuvant endocrine therapy while on endocrine therapy, or 2) for endocrine therapy in the locoregionally recurrent or metastatic setting, progression within first 6 months of initiating first-line endocrine therapy while on endocrine therapy. Patients receiving prior endocrine therapy who do not meet the definition of primary clinical resistance will be considered to have secondary clinical resistance.

The primary analysis of the PFS endpoint will occur after approximately 170 PFS events have been observed in Cohort A. An interim analysis will be conducted after approximately 119 PFS events are observed to provide early efficacy information and allow for potential early communication with regulatory agencies. (see Section 12.2.6 for details).

The interim analysis of Cohort B will follow the timeline of Cohort A, which will occur only if the interim of Cohort A turns out to be positive. If patients in Cohort A continue being followed for PFS until final analysis, the final analysis of Cohort B will be conducted at the same time of Cohort A final analysis. If Cohort A stops early at interim due to efficacy, the final analysis of Cohort B may be conducted after approximately 105 PFS events have been observed in Cohort B. (see Section 12.2.14 for details).

For each cohort, all patients will be followed for progression and survival information until death or study completion, whichever occurs first.

Terms used to describe the periods during the study are defined below:

- **Baseline:** begins when the informed consent form (ICF) is signed and ends at the first study treatment dose (or at discontinuation, if no treatment is given). This may be up to 28 days prior to the first study treatment dose.
- **Study Period:** begins at the first study treatment and ends at study completion. The study period does not include the continued access period.
  - **Study Treatment Period:** begins at the first study treatment and ends when the patient and the investigator agree that the patient will no longer continue study drug. The date of this agreement is to be reported on the electronic case report form (eCRF) as the Date of Discontinuation from study drug.
  - **Postdiscontinuation Follow-Up:** begins the day after the patient and the investigator agree that the patient will no longer continue study drug.

*Short-term follow-up* begins the day after the patient and the investigator agree that the patient will no longer continue study drug and lasts approximately 30 days ( $\pm 7$  days).

*Long-term follow-up* begins the day after short-term follow-up is completed and continues until the patient's death or overall study completion, whichever comes first.

- **Continued Access Period:** begins after study completion and ends at the end of trial. During the continued access period, patients on study treatment who continue to experience clinical benefit may continue to receive study treatment until one of the criteria for discontinuation is met.
  - The continued access period includes continued access period short-term follow-up.
  - Continued access short-term follow-up: begins the day after the patient and the investigator agree that the patient will no longer continue treatment in the continued access period and lasts approximately 30 days.

### **8.1.1. Study Completion and End of Trial**

This study will be considered complete following the last required PFS event from Cohort A (Figure JPBQ.8.2), as determined by Lilly. In case Cohort A stops early at interim due to efficacy and Cohort B continues thereafter, Cohort B will be considered complete following the final analysis of PFS in Cohort B. Investigators will continue to follow the study schedule for all patients until notified by Lilly that study completion has occurred.

The end of trial occurs after study completion and after the last patient has discontinued study treatment and completed any applicable continued access follow-up.

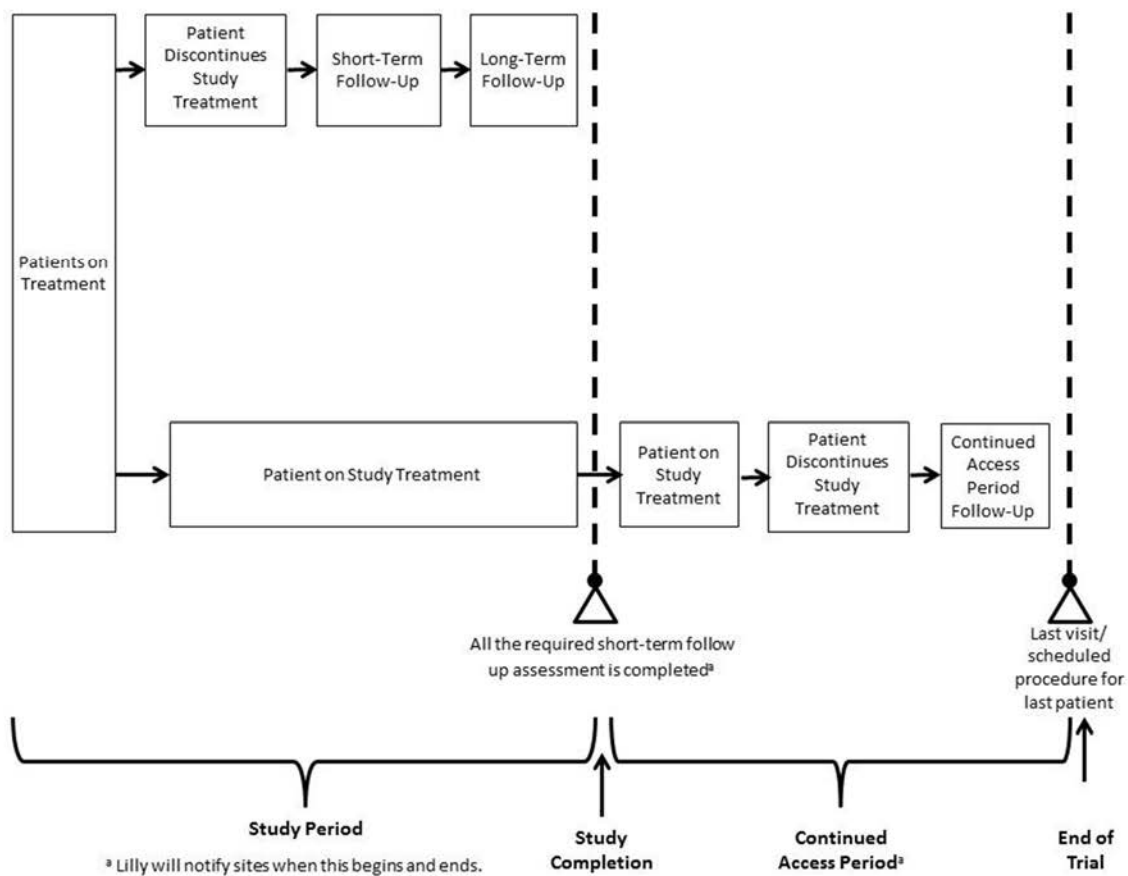

**Figure JPBQ.8.2. Study period and continued access diagram.**

### **8.1.2. Continued Access Period**

After study completion, all patients who are on study treatment and who are eligible for continued access will be unblinded. Patients receiving study treatment and experiencing ongoing clinical benefit and no undue risks may continue to receive study treatment in the continued access period until one of the criteria for discontinuation is met (see Section 7.3). Lilly will notify investigators when the continued access period begins.

Long-term follow-up does not apply in the continued access period.

Patients who are in long-term follow-up when the continued access period begins will be discontinued from long-term follow-up.

During the continued access period, all AEs, SAEs, and study drug exposure will be reported on the case report form (CRF). Serious adverse events will also be reported to Lilly Global Patient Safety (see Section 10.3.1). In the event that an SAE occurs, Lilly may request additional information (such as local laboratory results, concomitant medications, and hospitalizations) in order to evaluate the reported SAE.

Investigators will perform any other standard procedures and tests needed to treat and evaluate patients; however, the choice and timing of the tests will be at the investigator's discretion. Lilly will not routinely collect the results of these assessments.

## 8.2. Discussion of Design and Control

A randomized, controlled design is being used in this study. Randomization minimizes systematic bias in the selection and assignment of patients to study therapy and provides justification for inferential statistical methods to be used on data from this study. Using an appropriate concurrent control arm enables direct statistical estimation of benefits and harms due to study therapy and minimizes bias in the assessment and interpretation of observed treatment effects. Patients will be stratified for differences in factors thought to be associated with clinical outcomes to further reduce the potential for bias and improve the power of the analyses. Assessment of bias is further minimized by the use of a double-blind placebo control (see Section 9.3).

Investigational treatment administration in this study is double-blind; that is, patients, investigational sites, and the sponsor study team do not have immediate access to investigational treatment assignments for any patients. This design feature minimizes potential bias due to knowledge of patient's treatment during evaluation of study endpoints, at the patient level or aggregated across patients.

The 4-arm design of this study will allow 2 investigations in 1 specific population (ie, HR+, HER2- locoregionally recurrent or metastatic breast cancer). Patients in different cohorts will receive 2 standard endocrine therapies with or without abemaciclib, based on prior treatments and associated outcome, respectively. Furthermore, this design allows descriptive comparison of safety between different combinations or potential pooled analysis within the same setting by eliminating cross-trial confounders and following a consistent data collection plan.

## 9. Treatment

### 9.1. Treatments Administered

The following treatments will be administered in this study:

- Arm A1: Abemaciclib 150 mg orally Q12H plus either anastrozole 1 mg or letrozole 2.5 mg orally Q24H on Days 1 to 28 of a 28-day cycle.
- Arm A2: Placebo orally Q12H plus either anastrozole 1 mg or letrozole 2.5 mg orally Q24H on Days 1 to 28 of a 28-day cycle.
- Arm B1: Abemaciclib 150 mg orally Q12H on Days 1 to 28 of a 28-day cycle plus fulvestrant 500 mg intramuscularly on Days 1 and 15 of Cycle 1, then on Day 1 of Cycle 2 and beyond
- Arm B2: Placebo orally Q12H on Days 1 to 28 of a 28-day cycle plus fulvestrant 500 mg intramuscularly on Days 1 and 15 of Cycle 1, then on Day 1 of Cycle 2 and beyond

Blinded study drug is defined as abemaciclib or placebo. Study treatment is defined as blinded study drug and/or NSAI/fulvestrant.

The specific NSAI (anastrozole or letrozole) administered to patients in Cohort A is determined by the investigator. Patients should remain on the same NSAI throughout the study. In exceptional cases, in the absence of evidence of PD, the investigator may discuss a change in NSAI with the Lilly CRP. Nonsteroidal aromatase inhibitor is a co-administered standard-of-care treatment. The investigator should refer to the NSAI label (ie, Patient Information Leaflet, Package Insert, or Summary of Product Characteristics).

Fulvestrant 500 mg should be administered intramuscularly into the buttocks of patients in Cohort B slowly (1 to 2 minutes per injection) as two 250-mg injections, one in each buttock; however, for patients with moderate hepatic impairment (defined as Child-Pugh Class B), including any patient who develops moderate hepatic impairment during study treatment, fulvestrant 250 mg should be administered intramuscularly into the buttock slowly (1 to 2 minutes) as one 250-mg injection. Fulvestrant is a co-administered standard-of-care treatment. The investigator should refer to the fulvestrant label (ie, Patient Information Leaflet, Package Insert, or Summary of Product Characteristics).

[Table JPBQ.9.1](#) shows the treatment regimens.

**Table JPBQ.9.1. Treatment Regimens/Dosing Schedule**

Regimen	Period/Cycle	Dose Day
<b>Arm A1</b>		
Abemaciclib	Treatment/28-day cycle	150 mg PO Q12H on Days 1-28
Anastrozole or Letrozole	Treatment/28-day cycle	1 mg PO Q24H on Days 1-28 <sup>a</sup> or 2.5 mg PO Q24H on Days 1-28 <sup>a</sup>
<b>Arm A2<sup>b</sup></b>		
Placebo	Treatment/28-day cycle	PO Q12H on Days 1-28
Anastrozole or Letrozole	Treatment/28-day cycle	1 mg PO Q24H on Days 1-28 <sup>a</sup> or 2.5 mg PO Q24H on Days 1-28 <sup>a</sup>
<b>Arm B1</b>		
Abemaciclib	Treatment/28-day cycle	150 mg PO Q12H on Days 1-28
Fulvestrant	Treatment/28-day cycle	500 mg IM on Days 1 and 15 of Cycle 1, then Day 1 of Cycle 2 and beyond <sup>c</sup>
<b>Arm B2<sup>d</sup></b>		
Placebo	Treatment/28-day cycle	PO Q12H on Days 1-28
Fulvestrant	Treatment/28-day cycle	500 mg IM on Days 1 and 15 of Cycle 1, then Day 1 of Cycle 2 and beyond <sup>c</sup>

Abbreviations: IM = intramuscular; NSAI = nonsteroidal aromatase inhibitor; Q12H = once every 12 hours; Q24H = once every 24 hours; PK = pharmacokinetic; PO = orally.

<sup>a</sup> For PK purposes, NSAI should be administered at the same time (or up to 20 minutes after) the first dose of blinded study drug through Cycle 4, Day 1. Subsequently, the interval between administration of blinded study drug and NSAI may be adjusted based on the judgment of the investigator.

<sup>b</sup> For patients in Arm A2 who crossover to Arm A1, the Arm A1 treatment schedule should be followed.

<sup>c</sup> For PK purposes, fulvestrant should be administered at the same time as (or up to 20 minutes after) the first dose of blinded study drug, except when specified otherwise in the PK Sampling Schedule ([Attachment 7](#)) through Cycle 4 Day 1. Subsequently, the interval between administration of blinded study drug and fulvestrant may be adjusted based on the judgment of the investigator.

<sup>d</sup> For patients in Arm B2 who crossover to Arm B1, the Arm B1 treatment schedule should be followed.

The investigator or his/her designee is responsible for the following:

- explaining the correct use of the drugs and planned duration of each individual's treatment to the patient/site personnel/legal representative,
- verifying that instructions are followed properly,
- maintaining accurate records of study drugs dispensing and collection, and
- returning all unused medication to Lilly or its designee at the end of the study.

**Note:** In some cases, sites may destroy the material if, during the investigator site selection, the evaluator has verified and documented that the site has appropriate facilities and written procedures to dispose clinical trial materials.

Patients will be instructed to contact the investigator as soon as possible if they have a complaint or problem with the study drug or drug delivery system so that the situation can be assessed.

## 9.2. Materials and Supplies

Abemaciclib or placebo (blinded study drug) will be supplied as capsules for oral administration. Blinded study drug capsules should be stored according to the product label, and not opened, crushed, or dissolved. Blinded study drug will be labeled according to the country's regulatory requirements.

Where required, letrozole, anastrozole, and fulvestrant will be supplied by Lilly and labeled according to country regulatory requirements. All drugs should be stored according to the product label and will be provided as anastrozole 1-mg and letrozole 2.5-mg tablets or fulvestrant 250-mg prefilled syringes (250 mg/5 mL).

Investigators should instruct patients to store the blinded study drug and NSAI in the original package provided and in a location inaccessible to children.

Fulvestrant should be stored according to the instructions on the product label and administered according to the instructions in the protocol.

## 9.3. Method of Assignment to Treatment

Upon obtaining informed consent, site personnel should access the interactive web response system (IWRS). Patients who meet all criteria for enrollment will be randomly assigned to receive either abemaciclib plus NSAI/fulvestrant or placebo plus NSAI/fulvestrant. Assignment to treatment groups will be determined by a computer-generated random sequence using the IWRS. Sites will be prompted to enter the specific NSAI at time of randomization for patients in Cohort A.

Randomization will be stratified by the following in Cohort A: nature of disease (visceral metastases vs. non-visceral metastases), and prior (neo)adjuvant endocrine therapy (prior therapy with disease-free interval > 12 months from completion of treatment vs. prior therapy with disease-free interval ≤ 12 months from completion of treatment vs. no prior therapy).

Randomization will be stratified by the following in Cohort B: nature of disease (visceral metastases vs. non-visceral metastases) and sensitivity to endocrine therapy (primary resistance vs. secondary resistance).

The IWRS will be used to assign abemaciclib or placebo and distribute NSAI/fulvestrant supplied by Lilly (except distribution of NSAI in China). Site personnel will confirm that they have located the correct study medication packages by entering a confirmation number found on the packages into the IWRS.

The period between randomization to blinded study drug and the first dose (Cycle 1, Day 1) should not exceed 7 days.

## 9.4. Selection and Timing of Doses

Blinded study drug will be taken orally every 12 ( $\pm 2$ ) hours on Days 1 through 28 of a 28-day cycle, for a total of 56 doses per cycle. During all cycles, blinded study drug should be taken at approximately the same times each day. If a patient misses or vomits a dose, that dose should be omitted.

Anastrozole or letrozole will be administered orally every 24 hours ( $\pm 2$ ) on Days 1 through 28 of a 28-day cycle for a total of 28 doses per cycle. For PK purposes, anastrozole or letrozole should be administered at the same time as (or up to 20 minutes after) the first dose of blinded study drug through Cycle 4, Day 1. Subsequently, the interval between administration of blinded study drug and anastrozole or letrozole may be adjusted based on the judgment of the investigator. If a patient misses or vomits an anastrozole or letrozole dose, that dose should be omitted.

Fulvestrant will be administered intramuscularly on Days 1 and 15 of Cycle 1, then on Day 1 of Cycle 2 and beyond. For PK purposes, fulvestrant should be administered at the same time as (or up to 20 minutes after) the first dose of blinded study drug, except when specified otherwise in the PK Sampling Schedule ([Attachment 7](#)) through Cycle 4, Day 1. Subsequently, the interval between administration of blinded study drug and fulvestrant may be adjusted based on the judgment of the investigator.

In the event of a dose suspension of blinded study drug due to toxicity at the beginning of a cycle, the PK Sampling Schedule may require adjustment. In these exceptional circumstances, the sponsor should be notified.

A cycle is defined as an interval of 28 days plus any subsequent delay prior to start of the next cycle. A delay in the start of a cycle due to holidays, weekends, bad weather, or other unforeseen circumstances will be permitted up to 7 days and not counted as a protocol deviation).

A patient may continue to receive study treatment until she meets 1 or more of the specified reasons for discontinuation (as described in [Section 7.3](#)).

### 9.4.1. Special Treatment Considerations

#### 9.4.1.1. Dose Adjustments and Delays

Toxicity dose adjustments and delays of blinded study drug for this study are summarized in [Table JPBQ.9.2](#).



**Table JPBQ.9.2. Toxicity Dose Adjustments and Delays of Blinded Study Drug for Study JPBQ**

Toxicity Type	Toxicity Profile and Severity	Dose Suspension	Dose Reduction
Hematologic Toxicity Section 9.4.1.1.3	Grade 3	Dose <b>MUST</b> be suspended until toxicity resolves to at least Grade 2.	Dose <b>MAY</b> be reduced by 1 dose level at investigator's discretion.
Hematologic Toxicity Section 9.4.1.1.3	Recurrent Grade 3 within 8 weeks	Dose <b>MUST</b> be suspended until toxicity resolves to at least Grade 2.	Dose <b>MUST</b> be reduced by 1 dose level.
Hematologic Toxicity Section 9.4.1.1.3	Grade 4	Dose <b>MUST</b> be suspended until toxicity resolves to at least Grade 2.	Dose <b>MUST</b> be reduced by 1 dose level.
Hematologic toxicity: <b>If patient requires administration of blood cell growth factors</b> Sections 9.4.1.1.3 and 9.6.4	Regardless of severity (Use growth factors according to ASCO Guidelines)	Dose <b>MUST</b> be suspended for at least 48 hours after the last dose of blood cell growth factors was administered and until toxicity resolves to at least Grade 2.	Dose <b>MUST</b> be reduced by 1 dose level unless already performed for incidence of toxicity that led to the use of growth factor.
Nonhematologic Toxicity <sup>b</sup> (except diarrhea and ALT increased) Section 9.4.1.1.4	Persistent or recurrent Grade 2 that does not resolve with maximal supportive measures within 7 days to baseline or Grade 1	Dose <b>MUST</b> be suspended until toxicity resolves to either baseline or Grade 1.	Dose <b>MUST</b> be reduced by 1 dose level.
Nonhematologic Toxicity Section 9.4.1.1.4	Grade 3 or 4	Dose <b>MUST</b> be suspended until toxicity resolves to either baseline or Grade 1.	Dose <b>MUST</b> be reduced by 1 dose level.
Diarrhea Sections 9.4.1.1.4.1 and 9.6.5	Grade 2 that does not resolve within 24 hours to at least Grade 1	Dose <b>MUST</b> be suspended until toxicity resolves to at least Grade 1.	Dose reduction is NOT required.
Diarrhea Sections 9.4.1.1.4.1 and 9.6.5	Persistent or recurrent Grade 2 that does not resolve with maximal supportive measures, or any Grade of diarrhea that requires hospitalization	Dose <b>MUST</b> be suspended until toxicity resolves to at least Grade 1.	Dose <b>MUST</b> be reduced by 1 dose level.
Diarrhea Sections 9.4.1.1.4.1 and 9.6.5	Grade 3 or 4	Dose <b>MUST</b> be suspended until toxicity resolves to at least Grade 1.	Dose <b>MUST</b> be reduced by 1 dose level.
ALT Increased (Sections 9.4.1.1.4.2. and 10.3.3.1)	Persistent or recurrent <sup>a</sup> Grade 2 (>3.0-5.0×ULN), or Grade 3 (>5.0-20.0×ULN) <sup>c</sup>	Dose <b>MUST</b> be suspended until toxicity resolves to baseline or Grade 1.	Dose <b>MUST</b> be reduced by 1 dose level.

ALT Increased (Sections 9.4.1.1.4.2 and 10.3.3.1)	Grade 4 (>20.0×ULN)	Blinded study drug <b>MUST</b> be discontinued.	Blinded study drug <b>MUST</b> be discontinued.
ALT Increased with increased total bilirubin, in the absence of cholestasis (Sections 9.4.1.1.4.2)	Grade 3 increased ALT (>5.0 × ULN) with total bilirubin >2 × ULN	Blinded study drug <b>MUST</b> be discontinued	Blinded study drug <b>MUST</b> be discontinued

Abbreviation: ALT = alanine transaminase; ASCO = American Society of Clinical Oncology.

Note: MUST = mandatory.

- a Determination of persistent events will be at the discretion of the investigator. Recurrent toxicity refers to the same event occurring within the next 8 weeks (as measured from the stop date of the preceding event). As a general guidance, based on the risk/benefit balance assessment per the investigator, for a patient who experiences a new episode of Grade 3 hematological toxicity after more than 8 weeks following the last episode of same Grade 3 hematological toxicity, the investigator may consider resuming the patient on the same drug dose should the patient satisfy the following conditions:
- shows stable hematological counts (Grade ≤2) during that timeframe
  - has absence of any signs or risk of infection
  - is benefiting from study treatment
- b Additional guidance for renal and hepatic monitoring is in Sections 10.3.3.1 and 10.3.3.2
- c Grade 3 ALT increased is a trigger for additional assessments and possibly hepatic monitoring. See Section 10.3.1.1 for additional guidance for hepatic monitoring

### 9.4.1.1.1. Dose Adjustments

#### 9.4.1.1.1.1. Blinded Study Drug

Blinded study drug dose adjustments are allowed both within a cycle and between cycles. Blinded study drug must be reduced as outlined in Table JPBQ.9.3.

For patients requiring dose reduction(s), re-escalation to a prior dose level is permitted only after consultation with the Lilly CRP.

**Table JPBQ.9.3. Dose Adjustments for Abemaciclib**

Dose Adjustment	Oral Dose	Frequency
0	150 mg	Q12H
1	100 mg	Q12H
2	50 mg	Q12H

Abbreviation: Q12H = every 12 hours.

Blinded study drug must be discontinued if further dose reduction is required beyond 50 mg Q12H. If a patient who, in the judgment of the investigator, is receiving clinical benefit from study therapy requires further dose reduction than is outlined in Table JPBQ.9.3, then the investigator must discuss with the Lilly CRP prior to any further dose reduction.

In the event that blinded study drug must be discontinued, a patient may continue to receive anastrozole, letrozole, or fulvestrant.

**9.4.1.1.1.2. NSAID/Fulvestrant**

Per NSAID labels, dose adjustment for anastrozole or letrozole is not applicable, as only a single-dose strength is approved for each medication. In exceptional cases, or in the absence of evidence of PD, the investigator may discuss a change in the specific NSAID administration (eg, switching from anastrozole to letrozole) with the Lilly CRP. In the event that anastrozole or letrozole must be discontinued, a patient may continue to receive blinded study drug per the investigator's clinical judgment.

Dose adjustment for fulvestrant will be determined by the investigator in accordance with the label. For patients with moderate hepatic impairment (defined as Child-Pugh Class B), including any patient who develops moderate hepatic impairment during study treatment, fulvestrant 250 mg should be administered intramuscularly into the buttock slowly (1 to 2 minutes) as one 250-mg injection. In the event that fulvestrant must be discontinued, a patient may continue to receive blinded study drug.

**9.4.1.1.2. Dose Suspension (within a Cycle) and Cycle Delay**

Both dose suspension (within a cycle) and cycle delay are permitted. When a dose suspension or cycle delay occurs related to toxicity (defined as an AE possibly related to study treatment per investigator judgment), the blinded study drug and/or NSAID/fulvestrant may be suspended or delayed as determined by the investigator's judgment.

Study treatment may be held up to 14 days within a cycle or at start of next cycle to permit sufficient time for recovery from the toxicity. If a dose suspension occurs within a cycle, the investigator may resume blinded study drug dosing at the same dose level for the remainder of the cycle or at reduced dose (assuming resolution to at least Grade 1 for non-hematological toxicity and at least Grade 2 for hematological toxicity). If the patient experiences the same toxicity with the same or greater severity (Common Terminology Criteria for Adverse Events [CTCAE] grade) requiring a dose suspension within a cycle or at start of the next cycle, the patient must be dose reduced and not re-challenged a second time at the prior dose level.

In the event of a dose suspension of blinded study drug during Cycle 1, fulvestrant may be administered as scheduled on Cycle 1 Day 15. If a toxicity possibly related to blinded study drug occurs prior to initiating the next cycle, fulvestrant may be administered and blinded study drug suspended until recovery from the toxicity.

If NSAID/fulvestrant is administered but blinded study drug is suspended, the date of NSAID/fulvestrant administration shall constitute Day 1 of the next cycle.

Patients not recovering from toxicity within 14 days should be considered for discontinuation of the blinded study drug and/or co-administered NSAID/fulvestrant. In exceptional circumstances, a delay >14 days is permitted upon agreement between the investigator and the Lilly CRP and blinded study drug dose adjustment is to be considered.

In the event of a cycle delay due to logistical reasons (eg, due to patient availability), the patient should continue on study treatment if the patient has adequate drug supply. If a patient's treatment is interrupted as a result of not having sufficient drug supply, the cycle may be delayed

up to 7 days (and not be considered a protocol violation). In exceptional circumstances, a delay >7 days is permitted upon agreement between the investigator and the Lilly CRP.

The start of a cycle may be delayed, or a current cycle interrupted, to allow a patient with locoregionally recurrent breast cancer rendered operable by study treatment to receive surgery ± radiotherapy. For additional information, refer to Section 9.6.1.

#### **9.4.1.1.3. Hematologic Toxicity**

If a patient experiences Grade 4 hematologic toxicity, then study treatment must be suspended (until the toxicity resolves to at least Grade 2) and the dose of blinded study drug must be reduced by 1 dose level as outlined in [Table JPBQ.9.3](#).

If a patient experiences Grade 3 hematologic toxicity, then study treatment must be suspended (until the toxicity resolves to at least Grade 2) and the dose of blinded study drug may be reduced by 1 dose level as outlined in [Table JPBQ.9.3](#) at the discretion of the investigator.

If the patient experiences a recurrent episode of Grade 3 hematologic toxicity within 8 weeks, then dosing must be suspended (until the toxicity resolves to at least Grade 2) and the dose of blinded study must be reduced by 1 dose level as outline in [Table JPBQ.9.3](#).

Recurrent toxicity refers to the same event occurring within the next 8 weeks (as measured from the stop date of the preceding event). As a general guidance, based on the risk/benefit balance assessment per the investigator, for a patient who experiences a new episode of Grade 3 hematological toxicity after more than 8 weeks following the last episode of same Grade 3 hematological toxicity, the investigator may consider resuming the patient on the same drug dose should the patient satisfy the following conditions:

- The patient showed stable hematological counts (Grade  $\leq 2$ ) during that timeframe
- In the absence of any signs or risk of infection
- The patient is benefiting from study treatment

If a patient requires administration of blood cell growth factors, the dose of study drug must be suspended for at least 48 hours after the last dose of blood cell growth factors was administered and until toxicity resolves to at least Grade 2, then reduced by 1 dose level as outlined in [Table JPBQ.9.3](#), if a dose reduction for the specific event necessitating the use of the growth factors has not already occurred.

Before re-initiation of blinded study drug, hematologic toxicity must resolve to at least Grade 2.

#### **9.4.1.1.4. Nonhematologic Toxicity**

If a patient experiences Grade  $\geq 3$  nonhematologic toxicity, then dosing must be suspended (until the toxicity resolves to either baseline or at least Grade 1) and the dose of blinded study drug must be reduced as outlined in [Table JPBQ.9.3](#).

If a patient experiences persistent or recurrent Grade 2 nonhematologic toxicity (except diarrhea; see Section 9.4.1.1.4.1 or ALT increased, refer to Section 9.4.1.1.4.2 ) possibly related to blinded

study drug that does not resolve with maximal supportive measures within 7 days to either baseline or Grade 1, then dosing must be suspended (until the toxicity resolves to either baseline or at least Grade 1) and the dose of blinded study drug must be reduced by 1 dose level as outlined in [Table JPBQ.9.3](#).

Before re-initiation of blinded study drug, nonhematologic toxicity (except alopecia and fatigue) must resolve to either baseline or at least Grade 1.

#### **9.4.1.1.4.1. Diarrhea**

A patient experiencing diarrhea requiring hospitalization (irrespective of grade, that is, requiring intravenous [IV] rehydration) or severe diarrhea (Grade 3 or 4; see [Attachment 9](#)) must have study treatment suspended (until the toxicity resolves to at least Grade 1) and must have the blinded study drug dose reduced by 1 dose level as outlined in [Table JPBQ.9.3](#).

If a patient experiences persistent or recurrent diarrhea that does not resolve with maximal supportive measures (refer to Section [9.6.5](#)) within 24 hours to at least Grade 1, then study treatment must be suspended (until the toxicity resolves to at least Grade 1) and the dose of blinded study drug must be reduced by 1 dose level as outlined in [Table JPBQ.9.3](#).

#### **9.4.1.1.4.2. Hepatic Toxicity**

Does modifications and management for increased ALT are provided in [Table JPBQ.9.2](#). For persistent or recurrent Grade 2 ALT increased that does not resolve with maximal supportive measures within 7 days to baseline or Grade 1, or Grade 3 ALT increased, blinded study drug must be suspended until the toxicity has resolved to at least Grade 1 and the dose must be reduced by 1 dose level. Discontinue blinded study drug for Grade 3 increased ALT ( $>5.0 \times$  ULN) with total bilirubin  $>2 \times$  ULN, in the absence of cholestasis. For Grade 4 ALT increased, the patient must be discontinued from blinded study drug. Refer to Section [10.3.3.1](#) for additional hepatic monitoring guidance.

## **9.5. Blinding**

This is a double-blind study.

To preserve the blinding of the study, a minimum number of Lilly personnel will see the randomization table and treatment assignments before the study is complete. Access to unblinded data/documents will be controlled by restricting access to the data/documents in Lilly's data and statistical warehouse. Any changes to this unblinding plan may be described in a protocol amendment, the Statistical Analysis Plan (SAP), and/or a separate unblinding plan document.

Efficacy information will not be shared between sites until the study is completed. Upon overall study completion (see Section [8.1.1](#)), investigators may unblind patients to study treatment assignment.

### **9.5.1. Unblinding at Interim Analyses**

One interim analysis for efficacy and safety will be conducted on Cohort A, using unblinded data of the cohort, under the guidance of an independent Data Monitoring Committee (DMC). The DMC will consist of at least 3 members, including at least 1 clinician and 1 statistician. The DMC will communicate any recommendations based on interim analyses to the Lilly Senior Management Designee (SMD). If necessary, the SMD may form an Internal Review Committee (IRC) to review and act upon the recommendations of the DMC. See Section 12.2.14 for details on the conduct of interim analyses.

### **9.5.2. Emergency Unblinding**

In case of an emergency, the investigator has the sole responsibility for determining if unblinding of a patient's treatment assignment is warranted. Patient safety must always be the first consideration in making such a determination. If the investigator decides that unblinding is warranted, the investigator should make every effort to contact the Lilly CRP prior to unblinding a patient's treatment assignment unless this could delay emergency treatment of the patient. If a patient's treatment assignment is unblinded, Lilly must be notified immediately.

Emergency unblinding for AEs must be performed through the IWRS. This option may be used ONLY if the patient's acute well-being requires knowledge of the patient's treatment assignment, or if the patient discontinues treatment due to disease progression based upon RECIST v1.1 (see Attachment 5) and knowledge of the patient's treatment assignment is deemed essential to the selection of the patient's next treatment regimen. In the case of disease progression, the investigator must consult with the Lilly CRP prior to unblinding.

All calls resulting in an unblinding event are recorded and reported by the IWRS. If the investigator or patient becomes unblinded, that patient will be discontinued from study treatment and will undergo postdiscontinuation follow-up (see Attachment 1).

### **9.5.3. Inadvertent Unblinding**

Every effort will be made to blind both the patient and the investigator to the identity of the treatment, but the inadvertent unblinding of a patient may occur. A double-blind study design is known to be imperfect in the oncolytic setting because the potential for individual unblinding exists due to treatment-related signs and symptoms. If an investigator, site personnel performing assessments, or patient is unblinded, the unblinding will not be sufficient cause (in and of itself) for that patient to be discontinued from study treatment or excluded from any safety or efficacy analyses.

Additionally, there may be ethical reasons to have the patient remain on the study treatment. For patients to continue on study treatment in the event of unblinding, the investigator must obtain specific approval from a Lilly CRP for the patient to continue in the study.

## **9.6. Concomitant Therapy**

Appropriate documentation of all forms of premedications, supportive care, and concomitant medications must be captured at each visit in the eCRFs and should be recorded throughout the

patient's participation in the study. Concomitant medications and supportive care therapies must also be documented at the time of discontinuation and at the 30-day short-term follow-up visit.

With the exceptions listed in the sections below, therapies for cancer (including hormonal anticancer therapies, chemotherapy, immunotherapy and herbal medicine) will not be permitted while patients are on study treatment. Use of megestrol acetate as an appetite stimulant is not permitted.

The results from human disposition (Study I3Y-MC-JPBD) and in vitro human recombinant cytochrome P450 (CYP) phenotyping studies indicate that abemaciclib is extensively metabolized primarily via CYP3A. Based on these findings, grapefruit juice as well as inducers (eg, phenytoin or carbamazepine) and strong inhibitors of CYP3A should be substituted or avoided if possible (see [Attachment 8](#)).

In addition, in vitro studies in cultured human hepatocytes indicate that abemaciclib and its major metabolites LSN2839567 (M2) and LSN3106726 (M20) down regulate messenger ribonucleic acid (mRNA) of 1 or more CYPs, including CYP1A2, CYP2B6, CYP2C8, CYP2C9, CYP2D6, and CYP3A, at clinically relevant concentrations. The mechanism of down regulation and its clinical relevance are presently not understood. Therefore, caution should be exercised when coadministering substrate drugs of the above CYPs with narrow therapeutic margin (see [Attachment 8](#)).

### **9.6.1. Surgery and/or Radiotherapy for Locoregionally Recurrent Breast Cancer**

A patient with locoregionally recurrent breast cancer may receive surgery ± radiotherapy if study treatment renders the tumor operable. However, such a patient should not receive study treatment for the period beginning at least 7 days prior to surgery and continuing until at least 14 days after completion of surgery ± radiotherapy to allow for tissue healing and recovery. There is no restriction on the duration of this period without study treatment and, after this period ends, study treatment may resume. Importantly, a patient who receives surgery ± radiotherapy for locoregionally recurrent breast cancer is not considered noncompliant and does not incur a protocol deviation.

### **9.6.2. Radiotherapy**

Except as described in Section 9.6.1, radiotherapy is not permitted without permanent discontinuation from study treatment. Except for a patient with locoregionally recurrent breast cancer rendered operable by study treatment who subsequently undergoes surgery + radiotherapy, all other patients requiring radiotherapy should discontinue permanently from study treatment and have a tumor assessment of the lesion(s) before receiving radiotherapy.

### **9.6.3. Supportive Care**

Patients should receive full supportive care to maximize quality of life. Patients will receive supportive care as judged by their treating physician. If it is unclear whether a therapy should be

regarded as supportive care, the investigator should consult the Lilly CRP. Use of any supportive care therapy should be reported on the eCRFs.

#### **9.6.4. Growth Factor**

Growth factors should not be administered to a patient to satisfy study inclusion criteria.

Growth factors may be administered in accordance with ASCO guidelines (Smith et al. 2015). Dosing of study drug must be suspended if the administration of growth factors is required and must not be recommenced within 48 hours of the last dose of growth factors having been administered. In the event of a patient experiences Grade 3 hematologic toxicity and requires the administration of growth factors, the dose of study drug must be reduced by 1 dose level on commencement, if a dose reduction for the specific event necessitating the use of the growth factors has not already occurred.

#### **9.6.5. Supportive Management for Diarrhea**

At randomization, patients should receive instructions on the management of diarrhea. In the event of diarrhea, supportive measures should be initiated as early as possible. These include the following:

- At the first sign of loose stools, the patient should initiate anti-diarrheal therapy (eg loperamide) and notify the investigator/site for further instructions and appropriate follow-up.
- Patients should also be encouraged to drink fluids (eg, 8 to 10 glasses of clear liquids per day).
- Site personnel should assess response within 24 hours
- If diarrhea does not resolve with anti-diarrheal therapy within 24 hours to at least Grade 1, blinded study drug should be suspended until diarrhea is resolved to at least Grade 1.
- When blinded study drug recommences dosing should be adjusted as outlined in Section 9.4.1.1.1.1 and Table JPBQ.9.3.

In severe cases of diarrhea, the measuring of neutrophil counts and body temperature and proactive management of diarrhea with antidiarrheal agents should be considered.

If diarrhea is severe (requiring IV rehydration) and/or associated with fever or severe neutropenia, broad-spectrum antibiotics such as fluoroquinolones must be prescribed.

Patients with severe diarrhea or any grade of diarrhea associated with severe nausea or vomiting should be carefully monitored and given intravenous fluid (IV hydration) and electrolyte replacement.

#### **9.6.6. Bisphosphonates and RANK-L Targeted Agents**

Patients with bone metastases present on baseline imaging should be appropriately treated with bisphosphonates or RANK-L targeted agents, per respective approved labels. Initiation of treatment with bone-modifying agents must begin at least 7 days prior to randomization.

Patients receiving bisphosphonates or RANK-L targeted agents should not switch treatments



while on study treatment. However, exceptional cases without evidence of PD may be considered in consultation with the Lilly CRP. These exceptional cases will not incur a protocol deviation.

## **9.7. Treatment Compliance**

Treatment compliance information for study treatment will be collected through patient dosing diaries and/or capsule/tablet counts at each visit, with the number of capsules/tablets taken relative to the number expected to be taken summarized for each cycle. The patient must take  $\geq 75\%$  of the planned doses for study treatment in a cycle to be deemed compliant. As outlined in Section 9.4.1.1.2, dose suspensions or delays may occur and will not result in a patient being considered as noncompliant. A patient may be considered noncompliant if she is judged by the investigator to have intentionally or repeatedly taken  $\geq 125\%$  of the planned doses of study treatment in a cycle.

Importantly, a patient who receives surgery  $\pm$  radiotherapy for locoregionally recurrent breast cancer is not considered noncompliant and does not incur a protocol deviation. For additional information, refer to Section 9.6.1.

Potential discontinuation of a patient due to study drug noncompliance will be discussed between the investigator and the Lilly CRP or clinical research scientist before any determination is made to discontinue the patient.

### **9.7.1. Patient Diaries**

The study will include patient diaries to provide dosing instructions, help patients with treatment planning, and track actual doses of study treatment taken by the patient. Information from the diaries may be used for documenting study treatment compliance, as well as for dosing time relative to PK blood draws and electrocardiogram (ECG) collection.

## 10. Efficacy, Health Outcome/Quality of Life Measures, Safety Evaluations, Sample Collection and Testing, and Appropriateness of Measurements

Written informed consent must be obtained prior to any study-specific pretreatment evaluations.

Study procedures related to efficacy, safety, health outcome/quality of life measures, and sample collection and testing assessments and their timing are described in the sections below and shown in the Study Schedule ([Attachment 1](#)).

### 10.1. Efficacy Measures

#### 10.1.1. Efficacy Assessments at Baseline and during Study Treatment

Within 28 days of randomization, baseline tumor measurements will be performed on each patient. The method of assessment used at baseline must be used consistently for serial tumor assessment throughout the study. Computed tomography (CT), including spiral CT, scans and magnetic resonance imaging (MRI) are the preferred methods of measurement. In addition, bone scintigraphy will be performed for all patients at baseline (within 28 days of randomization). However, prior bone scintigraphy (obtained as part of routine clinical care) within 45 days before Day 1 of Cycle 1 is also acceptable.

For all patients, imaging studies (CT, including spiral CT, or MRI scan of the chest, abdomen, and pelvis) will be performed locally at baseline and repeated between last 7 days of every second cycle beginning with Cycle 2 and continuing through Cycle 18, in the last 7 days of every third cycle after Cycle 18 (inclusive), and within 14 days of clinical progression per the Study Schedule ([Attachment 1](#)). It is recommended that CT imaging of the abdomen and pelvis be performed with IV contrast, whenever possible. For patients with known hypersensitivity to CT contrast material, a CT scan of the chest without contrast and gadolinium-enhanced MRI of the abdomen and pelvis are encouraged. The CT portion of a positron emission tomography (PET)-CT scan may be used as a method of response assessment if the site can document that the CT is of identical diagnostic quality to a diagnostic CT (with IV and oral contrast). A PET scan alone or as part of a PET-CT may be performed as part of routine clinical care but cannot be used to assess response according to RECIST v1.1.

For only those patients with bone lesions identified by bone scintigraphy at baseline, directed imaging using 1 of the following methods will be performed at baseline: X-ray, CT scan with bone windows, or MRI. Directed imaging using the same method as at the baseline bone lesion assessment should be repeated between last 7 days of every second cycle beginning with Cycle 2 and continuing through Cycle 18, in the last 7 days of every third cycle after Cycle 18 (inclusive), and within 14 days of clinical progression.

For patients with locoregionally recurrent breast cancer not amenable to curative treatment, MRI scan of the breast will be performed at baseline, if applicable. Breast MRI, if applicable, will be repeated between last 7 days of every second cycle beginning with Cycle 2 and continuing

through Cycle 18, in the last 7 days of every third cycle after Cycle 18 (inclusive), and within 14 days of clinical progression.

For patients with visible tumor (such as skin lesions), photography will be performed at baseline and each photographic image of the tumor should include a ruler. Photography should be repeated on Day 1 of every second cycle beginning with Cycle 3 and continuing through Cycle 19 (inclusive), on Day 1 of every third cycle after Cycle 19, and within 14 days of clinical progression. Photographic images may be taken more frequently based upon the discretion of the investigator or following the identification of new skin lesions post-baseline.

For patients continuing treatment during the continued access period (after study completion), efficacy assessments (frequency and type of assessments) will be at the discretion of the investigator.

The assessments should be performed prior to dosing at the beginning of the required cycle unless otherwise indicated.

### **10.1.2. Efficacy Assessments during the Study Period Postdiscontinuation Follow-Up**

Postdiscontinuation follow-up during the study period will be conducted as described in the Study Schedule ([Attachment 1](#)).

For those patients who are randomized and never receive study treatment or those who discontinue study treatment without objectively measured PD, the investigative sites will continue to monitor patients and periodically evaluate tumor response approximately every 8 weeks for the first 18 months following randomization and thereafter approximately every 12 weeks by the same method used at baseline and throughout the study until the patient has objective disease progression, or until the primary analysis of PFS. In addition, anticancer therapies initiated after study treatment discontinuation will be collected during this follow-up period. After the patient has objective disease progression, radiologic imaging and photographic images are no longer required and the patient will be followed up approximately every 12 weeks ( $\pm 14$  days) until the patient's death or overall study completion.

After study completion, efficacy assessments (frequency and type of assessments) will be at the discretion of the investigator.

Lilly will continue to collect survival data on all patients but may reduce data collection for other efficacy data. Lilly will notify investigators when this reduced data collection can begin.

### **10.1.3. Primary Efficacy Measure**

The primary efficacy measure is PFS in Cohort A as defined by RECIST v1.1 (Eisenhauer et al. 2009), provided in [Attachment 5](#).

The PFS time is measured from the date of randomization to the date of objective progression or the date of death due to any cause, whichever is earlier.

For those patients with nonmeasurable, bone-only disease (refer to Inclusion Criterion [4]), objective progression will be established if at least 1 of the following criteria is met:

- the appearance of 1 or more new lesions (in bone or outside of bone), or
- unequivocal progression of existing bone lesions.

According to RECIST v1.1, the finding of a new lesion should be unequivocal and not attributable to findings thought to represent something other than tumor (eg, some ‘new’ bone lesions may be simply healing or flare of preexisting lesions). Pathologic fracture, new compression fracture, or complications of bone metastases will not be considered as evidence of disease progression, unless at least 1 of the above criteria is met.

For those patients with locoregionally recurrent disease for whom surgery is performed with no evidence of residual disease post-operatively, objective progression will be established if at least 1 of the following criteria is met:

- local and/or regional recurrence, or
- new development of metastatic disease.

For those patients with locoregionally recurrent disease for whom surgery is performed while on study with evidence of residual disease post-operatively, new baseline measurements should be taken and RECIST applied.

If a patient is not known to have progressed or died at the time of analysis, PFS time will be censored at the last known progression-free assessment. See Section 12.2.6 for detailed censoring rules.

#### **10.1.4. Secondary Efficacy Measures**

The key secondary efficacy measure is PFS for Cohort B as defined by RECIST v1.1 (Eisenhauer et al. 2009), provided in [Attachment 5](#).

Lilly or its designee will collect and store all tumor measurement images on all enrolled patients throughout the study. An independent review of imaging scans may be performed by an independent panel of radiologists in the future to retrospectively validate investigator bias if there are any concerns.

The measurements to determine the secondary efficacy endpoints shown in [Table JPBQ.10.1](#) will also be collected at the times shown in the Study Schedule ([Attachment 1](#)) for both cohorts.

**Table JPBQ.10.1. Other Secondary Efficacy Endpoints**

Endpoint	Definition
Overall Survival (OS)	The time from the date of randomization to the date of death from any cause
Objective Response Rate	The proportion of patients with CR or PR according to RECIST v1.1
Disease Control Rate (DCR)	The proportion of patients with CR, PR, or SD according to RECIST v1.1
Duration of Response (DoR)	The time from the date of first evidence of a CR or PR to the date of objective progression or death from any cause, whichever is earlier
Clinical Benefit Rate (CBR)	The proportion of patients with CR, PR, or SD $\geq$ 6 months according to RECIST v1.1

Abbreviations: CR = complete response; PR = partial response; PS = performance status; RECIST = Response Evaluation Criteria in Solid Tumors; SD = stable disease.

**Overall Survival (OS):** OS duration is measured from the date of randomization of any study drug to the date of death from any cause. For each patient who is not known to have died as of the data-inclusion cutoff date for a particular analysis, OS will be censored for that analysis at the date of last contact prior to the data inclusion cutoff date (contacts considered in the determination of last contact date include AE date, lesion assessment date, visit date, and last known alive date).

**Objective Response Rate:** The objective response rate is the percentage of patients with a best response of CR or PR.

**Duration of Response (DoR):** The DoR time is defined only for responders (patients with a CR or PR). It is measured from the date of first evidence of CR or PR to the date of objective progression or the date of death due to any cause, whichever is earlier. If a responder is not known to have died or have objective progression as of the data inclusion cutoff date scores, duration of response will be censored at the last complete objective progression-free disease assessment date.

**Disease Control Rate (DCR):** The DCR is the percentage of patients with a best response of CR, PR, or SD.

**Clinical Benefit Rate (CBR):** The CBR is the percentage of patients with a best response of CR or PR, or SD for at least 6 months.

### 10.1.5. Exploratory Measures

The exploratory measures of this study are listed in [Table JPBQ.10.2](#).

**Table JPBQ.10.2. Exploratory Measures**

Pain intensity	Measure of cancer pain intensity
Biomarkers	Potential biomarkers related to the mechanism of action of abemaciclib, NSAI, fulvestrant, the cell cycle, and/or the pathogenesis of breast cancer
CTS	Change from baseline in the size of target lesions

Abbreviations: CTS = change in tumor size; NSAI = nonsteroidal aromatase inhibitor.

**Pain intensity:** Cancer pain intensity will be measured using the mBPI-sf assessment (see Section 10.2.1.1 for details).

**Biomarkers:** Exploratory analysis using blood will be done to explore potential biomarkers related to the mechanism of action of abemaciclib, NSAI, fulvestrant, the cell cycle, and/or the pathogenesis of breast cancer to better understand relationships of cellular signaling defects with clinical outcomes.

**Change in Tumor Size (CTS):** Change in tumor size will be measured using target lesion measurements selected for radiological evaluation. This measurement will only be available on patients with measureable disease.

## 10.2. Health Outcome/Quality of Life Measures

### 10.2.1. Patient-Reported Outcomes

The primary health outcomes research goal is to assess if abemaciclib combination therapy is able to impact the symptom burden and quality of life, as measured by the EORTC QLQ-C30 (Aaronson et al. 1993), and pain, as measured by the mBPI-sf.

Patient-reported questionnaires should be completed by patients when a language translation is available in which the patient is fluent or literate.

At each time point identified in the Study Schedule ([Attachment 1](#)), a paper copy of the mBPI-sf and the EORTC QLQ-C30 questionnaires should be administered to the patient prior to extensive interaction with site staff and study drug administration.

#### 10.2.1.1. Health-Related Quality of Life

Broadly used in cancer trials, validated, and available in over 80 different languages, the EORTC QLQ-C30 (Aaronson et al. 1993) is a reliable and validated tool that has supported quality-of-life text in the European Medicines Evaluation Agency labels. The EORTC QLQ-C30 self-reported general cancer instrument (Aaronson et al. 1993) consists of 30 items covered by 1 of 3 dimensions:

- global health status/quality of life (2 items)
- functional scales (15 total items addressing either physical, role, emotional, cognitive, or social functioning)
- symptom scales (13 total items addressing either fatigue, nausea/vomiting, pain, dyspnea, insomnia, appetite loss, constipation, diarrhea, or financial impact)

The EORTC QLQ-C30 questionnaire is administered per the Study Schedule ([Attachment 1](#)). The recall period is the past week, completion time is typically 5 to 7 minutes, and the questionnaire will be scored as described by the European Organization for Research and Treatment of Cancer (EORTC) scoring manual (Fayers et al. 2001). The EORTC population will include all patients who completed at least 1 baseline assessment followed by at least 1 EORTC assessment after 1 dose of study drug.

### 10.2.1.2. Pain Intensity

The mBPI-sf (Cleeland 1991) is an 11-item instrument used as a multiple-item measure of cancer pain intensity. In addition to pain intensity (4 items), the mBPI-sf is designed for patients to record the presence of pain in general and pain interference with function (general activity, mood, ability to walk, ability to perform normal work, relations with others, sleep, and enjoyment of life).

Responses for the mBPI-sf items are captured through the use of 11-point numeric rating scales anchored at 0 (*no pain or does not interfere*) and ranged through 10 (*pain as bad as you can imagine or completely interferes*). The mBPI-sf recall period is 24 hours; typical completion time for this instrument is less than 5 minutes. Focused analysis will be on “worst pain.”

Use of pain medication will be assessed in conjunction with the mBPI-sf assessment. Data on each individual prescription and over-the-counter analgesic medication will be recorded on the Concomitant Medications eCRF. The use of pain medications should be reviewed with the patient at each subsequent visit. Any changes to analgesic use (new or stopped analgesics) will be recorded on the eCRF. Pain medication will be classified into categories, using an analgesic ladder approach with medication category based on a World Health Organization scale. A therapy category will be assigned according to the maximum category of therapy administered based on analgesic data for that cycle.

The mBPI-sf population will include all patients who completed at least 1 baseline followed by at least 1 mBPI-sf “worst pain” assessment after 1 cycle of study drug (Cycle 2, Day 1 or later).

### 10.2.2. Resource Utilization

Investigators will be asked to report the use of concomitant medications (in particular, analgesics, bisphosphonates, and RANK-L targeted agents), blood product transfusions, radiation therapy, surgery, and hospitalization days. Data on neurosurgical blocks will be recorded on the Concomitant Medication and/or Surgery eCRF as appropriate. This information should be collected during the study and at the 30-day follow-up visit.

## 10.3. Safety Evaluations

Investigators are responsible for monitoring the safety of patients who have entered this study and for alerting Lilly or its designee to any event that seems unusual, even if this event may be considered an unanticipated benefit to the patient.

The investigator is responsible for the appropriate medical care of patients during the study.

The investigator remains responsible for following, through an appropriate health care option, AEs that are serious, considered related to the study, or that caused the patient to discontinue before completing the study. The patient should be followed until the event is resolved or explained. Frequency of follow-up evaluation is left to the discretion of the investigator.

The timing of all safety evaluations is shown in the Study Schedule ([Attachment 1](#)). [Table JPBQ.10.3](#) presents a summary of AE and SAE reporting guidelines and also shows which database or system is used to store AE and SAE data.

**Table JPBQ.10.3. Adverse Event and Serious Adverse Event Reporting Guidelines**

Period	Types of AEs/SAEs to be Reported	Collection Database	Lilly Safety System
Baseline (pretreatment)	Preexisting conditions All AEs SAEs related to protocol procedures	x x x	x
Study treatment period	All AEs All SAEs	x x	x
30-day short-term postdiscontinuation follow-up	All AEs  All SAEs	x  x	x
Long-term postdiscontinuation follow-up	All SAEs related to protocol procedures or study drug	x	x
Continued access period	All AEs All SAEs	x x	x
Continued access period follow-up	All AEs All SAEs	x x	x
After the patient is no longer participating in the study (that is, no longer receiving study therapy and no longer in follow-up)	All SAEs related to protocol procedures or study drug that the investigator becomes aware of		x

Abbreviations: AE = adverse event; SAE = serious adverse event.

### 10.3.1. Adverse Events

Lilly has standards for reporting AEs that are to be followed regardless of applicable regulatory requirements that may be less stringent. A clinical study AE is any untoward medical event associated with the use of a drug in humans, whether or not it is considered related to that drug.

Lack of drug effect is not an AE in clinical trials, because the purpose of the clinical trial is to establish drug effect.

Any clinically significant findings from ECGs, labs, vital sign measurements, and other procedures that result in a diagnosis should be reported to Lilly or its designee.

Study site personnel will record the occurrence and nature of each patient's preexisting conditions, including clinically significant signs and symptoms of the disease under treatment in the study.

After the ICF is signed, site personnel will record the occurrence and nature of any AEs and any change in the preexisting condition(s). All AEs related to protocol procedures are reported to Lilly or its designee.

The investigator will record all AE/SAE information in the CRF. Investigators will be instructed to report to Lilly or its designee their assessment of the potential relatedness of each AE to protocol procedure and/or study drugs via eCRF.

The investigator will decide whether he or she interprets the observed AEs as related to disease, to the study medication, study procedure, or other concomitant treatment or pathologies. To



assess the relationship of the AE to study drug or study procedure, the following terminologies are defined:

- **Probably related:** a direct cause and effect relationship between the study treatment and the AE is likely
- **Possibly related:** a cause and effect relationship between the study treatment and the AE has not been demonstrated at this time and is not probable, but is also not impossible
- **Does not know:** the investigator cannot determine
- **Not related:** without question, the AE is definitely not associated with the study treatment

The investigator should classify all “probably related,” “possibly related,” or “does not know” AEs and SAEs as related to study drug/study procedure.

Patients will be evaluated for AEs at each visit and will be instructed to call their physician to report any AEs between visits.

The National Cancer Institute (NCI) CTCAE (Version 4.0) will serve as the reference document for choosing appropriate terminology for, and grading the severity of, all AEs and other symptoms. For AEs without matching terminology within the NCI-CTCAE v 4.0] criteria, the investigator will be responsible for selecting the appropriate System Organ Class (SOC) and assessing severity grade based on the intensity of the event.

In addition to collecting the AE verbatim and the CTCAE severity grade, AE verbatim text will also be mapped by Lilly or its designee to corresponding terminology within the Medical Dictionary for Regulatory Activities (MedDRA) dictionary.

If a patient’s dosage is reduced or treatment is discontinued as a result of an AE, study site personnel must clearly report to Lilly or its designee via eCRF the circumstances and data leading to any such dosage reduction or discontinuation of treatment.

#### **10.3.1.1. Serious Adverse Events**

All AEs occurring after signing the ICF are recorded in the eCRF and assessed for serious criteria. An SAE is any AE from this study that results in 1 of the following outcomes:

- death
- a life-threatening experience (ie, immediate risk of dying)
- persistent or significant disability/incapacity
- initial or prolonged inpatient hospitalization
- congenital anomaly/birth defect
- considered significant by the investigator for any other reason

Important medical events that may not result in death, be life-threatening, or require hospitalization may be considered serious adverse drug events when, based upon appropriate medical judgment, they may jeopardize the patient and may require medical or surgical intervention to prevent one of the outcomes listed in this definition.

Serious adverse event collection begins after the patient has signed informed consent and has received study drug. If a patient experiences an SAE after signing informed consent, but prior to receiving study drug, the event will not be reported as serious unless the investigator feels the event may have been caused by a protocol procedure.

Data on SAEs that occur before the end of trial will be stored in the collection database and the Lilly Safety System.

Study site personnel must alert Lilly or its designee of any SAE within 24 hours of investigator awareness of the event via a sponsor-approved method. If study site personnel contact Lilly or its designee by telephone regarding an SAE, study site personnel must also immediately provide official notification on study-specific SAE forms.

This 24-hour notification requirement refers to the initial SAE information and all follow-up SAE information.

Planned surgeries should not be reported as SAEs unless the underlying medical condition has worsened during the course of the study.

Planned hospitalizations or procedures for preexisting conditions that are already recorded in the patient's medical history at the time of study enrollment should not be considered SAEs. Hospitalization or prolongation of hospitalization without a precipitating clinical AE (eg, for the administration of study treatment or other protocol-required procedure) should not be considered SAEs.

Serious adverse events due to disease progression, including death, should not be reported unless the investigator deems them to be possibly related to the study drug.

The investigator does not need to actively monitor patients for AEs once the trial has ended, unless provided otherwise in the protocol; however, if an investigator becomes aware of an SAE occurring after the patient's participation in the trial has ended, and the investigator believes that the SAE is related to a protocol procedure or study drug, the investigator should report the SAE to the sponsor, and the SAE will be entered in the Lilly Safety System.

Information on SAEs expected in the study population independent of drug exposure and that will be assessed by the sponsor in aggregate periodically during the course of the trial may be found in the IB.

#### **10.3.1.2. Suspected Unexpected Serious Adverse Reactions**

Suspected unexpected serious adverse reactions (SUSARs) are serious events that are not listed in the Development Core Safety Information in the IB and that the investigator identifies as related to the study drug or study procedure. United States 21 CFR 312.32 and European Union Clinical Trial Directive 2001/20/EC and the associated detailed guidances or national regulatory requirements in participating countries require the reporting of SUSARs. Lilly has procedures that will be followed for the recording and expedited reporting of SUSARs that are consistent with global regulations and associated detailed guidances.

### **10.3.2. Other Safety Measures**

#### **10.3.2.1. Electrocardiograms**

For each patient, 12-lead digital ECGs will be collected according to the Study Schedule ([Attachment 1](#)) as single ECGs. Patients must be resting for approximately 5 to 10 minutes before ECG collection and remain supine but awake during ECG collection.

Electrocardiograms may be obtained at additional times, when deemed clinically necessary. Collection of more ECGs than expected at a particular time point is allowed when needed to ensure high quality records.

Electrocardiograms will be interpreted by a qualified physician (the investigator or qualified designee) at the site as soon after the time of ECG collection as possible, and ideally while the patient is still present, to determine whether the patient meets entry criteria and for immediate patient management, should any clinically relevant findings be identified.

After enrollment, if a clinically significant increase in the QT interval/corrected QT interval (QTc) from baseline, or other clinically significant quantitative or qualitative change from baseline, is present, the investigator will assess the patient for symptoms (eg, palpitations, near syncope, syncope) and to determine if the patient can continue in the study. The investigator or qualified designee is responsible for determining if any change in patient management is needed and must document his/her review of the ECG printed at the time of evaluation.

#### **10.3.3. Safety Monitoring**

The Lilly CRP will monitor safety data throughout the course of the study.

Lilly will review SAEs within time frames mandated by company procedures. The Lilly CRP will, as appropriate, consult with the functionally independent Global Patient Safety therapeutic area physician or clinical scientist, and review:

- trends in safety data
- laboratory analytes
- AEs

In the event that safety monitoring uncovers an issue that needs to be addressed by unblinding at the group level, only members of the DMC (an advisory group for this study formed to protect the integrity of data; see [Section 12.2.14](#)) can conduct additional analyses of the safety data. Hematological and chemistry tests should be performed prior to dosing at the beginning of the required cycle unless otherwise indicated

##### **10.3.3.1. Special Hepatic Safety Data Collection**

If a study patient experiences elevated ALT  $\geq 5 \times$  ULN and elevated total bilirubin (TBL)  $\geq 2 \times$  ULN, or ALT  $> 8 \times$  ULN for patients with underlying baseline hepatic metastases, liver tests ([Attachment 4](#)), including ALT, AST, TBL, direct bilirubin, gamma glutamyl transferase (GGT), and creatine phosphokinase (CPK), should be repeated within 3 to 5 days to confirm the abnormality and to determine if it is increasing or decreasing. If the abnormality persists or

worsens, clinical and laboratory monitoring should be initiated by the investigator, based on the hepatic monitoring tests ([Attachment 3](#)) and in consultation with the Lilly CRP. Monitoring of ALT, AST, and TBL should continue until levels normalize or return to approximate baseline levels. Additional diagnostic testing should be considered to rule out cause of increased liver enzymes per the investigator's discretion.

Hepatic monitoring tests ([Attachment 3](#)) should be collected in the event that 1 or more of the following conditions is met for the patient during the course of the study:

- ALT  $\geq 5 \times$  ULN and TBL  $\geq 2 \times$  ULN
- ALT  $> 8 \times$  ULN for patients with underlying hepatic metastasis
- discontinuation from study treatment due to a hepatic event or an abnormality of liver tests

#### **10.3.3.2. Renal Function**

Abemaciclib has been shown to increase serum creatinine due to inhibition of renal tubular secretion of creatinine without affecting cystatin C-calculated glomerular filtration rate. Increases in serum creatinine occurred within the first 2 weeks of treatment, remained stable through the treatment period, and were reversible upon treatment discontinuation. If deterioration of renal function is suspected, serum creatinine should not be the only measure used to assess a patient's renal function.

Dose adjustment (omission, reduction, or discontinuation) should not solely be based on interpretation of serum creatinine values because these may not reflect renal function. If deterioration of renal function is suspected per the investigator's clinical assessment, dose alteration should follow the protocol guidance for non-hematological toxicities ([Table JPBQ 9.2](#)).

#### **10.3.3.3. Venous Thromboembolic Events**

In the randomized Phase 3 studies in breast cancer patients who received abemaciclib in combination with endocrine therapy, there was a greater number of patients who experienced VTEs in the abemaciclib plus endocrine therapy arm than in the placebo plus endocrine therapy arm. The majority of the events were non-serious and were treated with low-molecular-weight heparin. Generally, these events did not result in discontinuation of the study treatment. At this time, the mechanism underlying the association between abemaciclib and the occurrence of VTEs is not known. For suspected or confirmed VTE (eg. deep vein thrombosis or pulmonary embolism), treatment should occur according to usual clinical practice.

#### **10.3.4. Complaint Handling**

Lilly collects product complaints on study drugs used in clinical trials in order to ensure the safety of study participants, monitor quality, and facilitate process and product improvements.

Complaints related to unblinded concomitant drugs are reported directly to the manufacturers of those drugs/devices in accordance with the Package Insert.

For blinded studies, all product complaints associated with material packaged, labeled, and released by Lilly or its designee will be reported.

The investigator or his/her designee is responsible for handling the following aspects of the product complaint process in accordance with the instructions provided for this study:

- recording a complete description of the product complaint reported and any associated AEs using the study-specific complaint forms provided for this purpose
- faxing the completed product complaint form within 24 hours to Lilly or its designee.

If the investigator is asked to return the product for investigation, he/she will return a copy of the product complaint form with the product.

#### **10.4. Sample Collection and Testing**

[Attachment 1](#) lists the schedule for sample collections in this study.

[Attachment 2](#) lists the specific tests that will be performed for this study

[Attachment 6](#) provides a summary of the estimated maximum number and volume of invasive samples, for all sampling, during the study.

[Attachment 7](#) lists the schedule for PK sampling during the study.

##### **10.4.1. Samples for Study Qualification and Health Monitoring**

Blood samples will be collected to determine whether patients meet inclusion/exclusion criteria and to monitor patient health. In addition to protocol-specified tests, investigators should consider monitoring of cholesterol and bone mineral density if needed, per the recommendations for anastrozole and letrozole in the Package Insert and Summary of Product Characteristics.

Investigators must document their review of each laboratory safety report.

Samples collected for specified laboratory tests will be destroyed within 60 days of receipt of confirmed test results. Tests are run and confirmed promptly whenever scientifically appropriate. When scientific circumstances warrant, however, it is acceptable to retain samples to batch the tests run, or to retain the samples until the end of the study to confirm that the results are valid. Certain samples may be retained for a longer period, if necessary, to comply with applicable laws, regulations, or laboratory certification standards.

##### **10.4.2. Samples for Biomarkers**

Where local regulations and ERBs allow, samples for biomarker research to be collected from all patients in this study are the following:

- whole blood (Section [10.4.2.1](#))
- plasma (Section [10.4.2.2](#))

Analyses may include, but are not limited to, nucleic acid and protein profiles to better understand the disease process and to develop predictive biomarkers.

These samples are described in the following sections.

#### **10.4.2.1. Whole Blood Sample for Pharmacogenetic Evaluations**

There is growing evidence that genetic variation may impact a patient's response to therapy. Variable response to therapy may be due to genetic determinants that impact drug absorption, distribution, metabolism, and excretion, the mechanism of action of the drug, the disease etiology and/or the molecular subtype of the disease being treated. Therefore, where local regulations and ERBs allow, a blood sample will be collected for pharmacogenetic analysis.

Samples may be genotyped and analysis may be performed to evaluate a genetic association with response to abemaciclib, NSAID, and fulvestrant. These investigations may be limited to a focused candidate gene study or, if appropriate, genome-wide analysis may be performed to identify regions of the genome associated with the variability observed in drug response. The pharmacogenetic biomarker samples will only be used for investigations related to disease and drug or class of drugs under study in the context of this clinical program. They will not be used for broad exploratory unspecified disease or population genetic analysis.

The samples will be coded with the patient number and stored for up to a maximum 15 years or as local regulations and ERBs allow after the last patient visit for the study at a facility selected by the sponsor. The samples and any data generated from them can only be linked back to the patient by investigator site personnel. The duration allows the sponsor to respond to regulatory requests related to the study drug.

Samples will be destroyed according to a process consistent with local regulation.

#### **10.4.2.2. Plasma Samples for Exploratory Biomarker Evaluations**

Ethylenediamine tetraacetic acid(EDTA)-anticoagulated plasma samples will be collected and analysis may be performed on biomarkers that may play a role in the abemaciclib mechanism of action, the cell cycle, and/or breast cancer pathogenesis (refer to [Attachment 1](#)). Markers related to the NSAID and fulvestrant may also be assessed. The evaluation of these samples may involve analysis of DNA, RNA, and proteins (including any of these components derived from exosomes) to investigate their association with observed clinical outcomes to study drug. The samples will be coded with the patient number and stored for up to a maximum 15 years or as local regulations and ERBs allow.

#### **10.4.3. Samples for Drug Concentration Measurements Pharmacokinetics**

At the visits and times specified in the PK Sampling Schedule ([Attachment 7](#)), venous blood samples will be collected from at least 150 of the patients randomized in Cohort A and all patients randomized in Cohort B. These samples will be used to determine the plasma concentrations of abemaciclib and abemaciclib metabolites, as well as plasma concentrations of anastrozole, letrozole, or fulvestrant.

Instructions for the collection and handling of blood samples will be provided by the sponsor. It is preferred that the blood samples be obtained from a peripheral location. Blood samples will

be allowed from central access devices, but a sample drawn from a central catheter of any type for PK must take precautions to prevent obtaining a dilute sample. If multiple samples are obtained centrally, the PK sample should be the last specimen drawn to reduce the potential for a diluted or improperly drawn sample. The actual date and time (24-hour clock time) of each sampling will be recorded. A maximum of 5 samples may be drawn at additional time points during the study if warranted and agreed upon between both the investigator and Lilly.

These samples will be analyzed at a laboratory designated by the sponsor. Plasma concentrations of abemaciclib plus its major metabolites LSN2839567 and LSN3106726 will be assayed using a validated liquid chromatography/tandem mass spectrometry (LC-MS/MS) method. Plasma concentrations of anastrozole or letrozole or fulvestrant will also be analyzed using a validated LC-MS/MS method. Bioanalytical samples collected to measure study drug concentration and metabolism and/or protein binding, will be retained for a maximum of 1 year following last patient visit for the study. The PK samples will be stored at a facility designated by the sponsor.

Drug concentration information that may unblind the study will not be reported to investigative sites or blinded personnel until the study has been unblinded.

### **10.5. Appropriateness of Measurements**

Efficacy measurements by radiographic imaging are standard, widely used, and generally recognized as reliable, accurate, and able to discriminate between effective and ineffective agents.

Safety measurements by laboratory monitoring are standard, widely used, and generally recognized as reliable, accurate, and able to discriminate between agents with acceptable and unacceptable safety profiles.

## 11. Data Quality Assurance

To ensure accurate, complete, and reliable data, Lilly or its representatives will do the following:

- provide instructional material to the study sites, as appropriate
- sponsor start-up training to instruct the investigators and study coordinators. This session will give instruction on the protocol, the completion of the CRFs, and study procedures.
- make periodic visits to the study site
- be available for consultation and stay in contact with the study site personnel by mail, telephone, and/or fax
- review and evaluate CRF data and use standard computer edits to detect errors in data collection
- conduct a quality review of the database

In addition, Lilly or its representatives will periodically check a sample of the patient data recorded against source documents at the study site. The study may be audited by Lilly or its representatives, and/or regulatory agencies at any time. Investigators will be given notice before an audit occurs.

To ensure the safety of participants in the study, and to ensure accurate, complete, and reliable data, the investigator will keep records of laboratory tests, clinical notes, and patient medical records in the patient files as original source documents for the study. If requested, the investigator will provide Lilly, applicable regulatory agencies, and applicable ERBs with direct access to original source documents.

### 11.1. Data Capture System

An electronic data capture system will be used in this trial. The site maintains a separate source for the data entered by the site into the sponsor-provided electronic data capture system.

Case report form data will be encoded and stored in a clinical trial database.

Any data for which the paper documentation provided by the patient will serve as the source document will be identified and documented by each site in that site's study file. Paper documentation provided by the patient may include, for example, a paper diary to collect patient-reported outcome (PRO) measures (eg, a rating scale), a daily dosing schedule, or an event diary.

Bioanalytical data will be stored electronically in the bioanalytical laboratory's database. Data will subsequently be transferred from the bioanalytical laboratory to the Clinical Laboratory Results Modernization system.

Data from complaint forms submitted to Lilly will be encoded and stored in the global product complaint management system.



## 12. Sample Size and Statistical Methods

### 12.1. Determination of Sample Size

The primary objective of this study is to compare abemaciclib plus NSAI versus placebo plus NSAI in terms of PFS in postmenopausal women with HR+, HER2- locoregionally recurrent or metastatic breast cancer.

The key secondary objective of this study is to compare abemaciclib plus fulvestrant versus placebo plus fulvestrant with respect to PFS for postmenopausal women with HR+, HER2- locoregionally recurrent or metastatic breast cancer.

The study plan is to enroll approximately 450 patients in total, with 300 HR+, HER2- locoregionally recurrent or metastatic breast cancer patients who have not received prior endocrine therapy in Cohort A and 150 HR+, HER2- locoregionally recurrent or metastatic breast cancer patients in Cohort B. Assuming approximately 10% screening failure, the study will enter approximately 500 patients.

The approximate 300 patients qualified for Cohort A will be randomized in a 2:1 ratio to Arm A1 (abemaciclib plus NSAI; 200 patients) and Arm A2 (placebo plus NSAI; 100 patients). Patients will be randomized using the following stratification factors: nature of disease (visceral metastases vs. non-visceral metastases) and prior (neo)adjuvant endocrine therapy (prior therapy with disease-free interval > 12 months from completion of treatment vs. prior therapy with disease-free interval ≤ 12 months from completion of treatment vs. no prior therapy).

A 2-look group-sequential design of the primary endpoint will be used to accommodate an event-driven plan for the interim and primary PFS analyses (see Section 12.2.6 for details). The primary PFS analysis will be performed after approximately 170 PFS events in Cohort A have occurred (ie, approximately 43% censoring rate). Assuming a hazard ratio of 0.626, this sample size yields about 81.40% statistical power to detect superiority of the abemaciclib plus NSAI arm over the placebo plus NSAI arm with the use of a 1-sided log-rank test and a type I error of 0.025. If the true median PFS for the placebo plus NSAI arm is 14.4 months, then the hazard ratio of 0.626 amounts to an approximately 8.6-month (59.7%) improvement in median PFS for the abemaciclib plus NSAI arm under an additional assumption of exponential survival distribution.

Approximately 150 patients will be randomized in a 2:1 ratio to Arm B1 (abemaciclib plus fulvestrant; 100 patients) and Arm B2 (placebo plus fulvestrant; 50 patients). Patients will be randomized using the following stratification factors: nature of disease (visceral metastases vs. non-visceral metastases) and sensitivity to endocrine therapy (primary resistance vs. secondary resistance).

The design of Cohort B is to ensure 100 patients' exposure of abemaciclib plus fulvestrant and to show 50% of the global study JPBL trial effect size with roughly 80% probability (ie, 80% of chance to observe a hazard ratio less than 0.824, assuming a true hazard ratio of 0.703 by study assumption).

Here, the effect size of the drug is defined as:

$$\delta = \frac{1}{HR} - 1 = \frac{1 - HR}{HR} = \frac{MST_{Test} - MST_{Control}}{MST_{Control}}$$

$MST_{Test}$  and  $MST_{Control}$  are median survival time in test drug group and control drug group, respectively; effect size can be regarded as the percent change of median survival time.

## 12.2. Statistical and Analytical Plans

### 12.2.1. General Considerations

Statistical analysis of this study will be the responsibility of Lilly.

Efficacy analyses will be based on the intention-to-treat (ITT) analysis set. This population is defined as all patients randomized to study treatment. Patients will be grouped according to randomized treatment.

Safety analyses will be based on the randomized and treated population (ie, Safety Population), defined as all randomized patients receiving at least 1 dose of blinded study drug or NSAID/fulvestrant. Patients will be grouped according to treatment received in Cycle 1.

Pharmacodynamic and/or biomarker analyses will be based on the subset of patients from the above populations from whom a valid assay result (according to laboratory guideline) has been obtained.

All tests of treatment effects will be conducted at a 2-sided alpha level of 0.05, unless otherwise stated. All confidence intervals (CIs) will be given at a 2-sided 95% level, unless otherwise stated.

Any change to the data analysis methods described in the protocol will require an amendment ONLY if it changes a principal feature of the protocol.

Before sponsor unblinding of the aggregate database, minor modifications or clarifications to the data analysis methods may be described and justified in the SAP.

Any other change to the data analysis methods described in the protocol, and the justification for making the change, will be described in the clinical study report (CSR).

The assumptions for each statistical method may be evaluated. If there is violation of assumptions, alternative statistical methods may be used.

Additional exploratory analyses of the data will be conducted as deemed appropriate.

### 12.2.2. Patient Disposition

A detailed description of patient disposition will be provided. It will include a summary of the number and percentage of patients entered into the study, enrolled in the study, and treated, as well as the number and percentage of patients completing the study or discontinuing (overall and by reason for discontinuation).

All patients entered in the study will be accounted for in the summation. The number of patients who do not qualify for analysis, who die, or who discontinue before treatment begins will be specified.

A summary of all important protocol deviations will be provided.

### **12.2.3. Patient Characteristics**

Patient characteristics will include a descriptive summary, by treatment arm, of the following:

- patient demographics
- baseline disease characteristics
- preexisting conditions
- historical illnesses
- prior (neo)adjuvant endocrine therapy
- prior (neo)adjuvant chemotherapy (including both cytotoxic and targeted agents)
- prior endocrine therapy
- prior chemotherapy (including both cytotoxic and targeted agents)

Other patient characteristics will be summarized as deemed appropriate.

### **12.2.4. Concomitant Therapy**

Concomitant medication will be summarized by treatment arm in a frequency table listing the terms recorded on the eCRF.

#### **12.2.4.1. Postdiscontinuation Therapy**

The numbers and percentages of patients reporting postdiscontinuation therapies will be provided overall, by type of therapy (surgery, radiotherapy, or systemic therapy), and by drug name.

### **12.2.5. Treatment Compliance**

The number of dose omissions, reductions, and delays, cycles received, and dose intensity will be summarized for all treated patients per treatment arm.

Treatment compliance information for abemaciclib will be collected through capsules counts at each tumor assessment visit. The estimate of percent compliance will be given by:

$$\text{Percent Compliance} = \frac{\text{Actual cumulative dose taken}}{\text{Expected cumulative dose to be taken}} \times 100$$

The actual cumulative dose taken will be determined based on counting the number of capsules returned at each visit and subtracting that number from the number of capsules dispensed. The expected cumulative dose to be taken will be determined based on the assigned dose and taking into account any dose reductions or omissions.

### 12.2.6. Primary Outcome and Methodology

The primary endpoint of this study is PFS in Cohort A. Progression-free survival time is measured from randomization until the date of objective progression as defined by RECIST v1.1, or death from any cause. Patients who have neither progressed nor died will be censored at the day of their last radiographic tumor assessment, if available, or date of randomization if no post-initiation (ie, post-baseline) radiographic assessment is available. The detailed censoring rules are described in [Table JPBQ.12.1](#).

**Table JPBQ.12.1. Rules for Determining Date of Progression or Censor for Progression-Free Survival**

Rule	Situation	Date of Progression or Censor	Outcome
1	No baseline tumor assessments	Date of randomization	Censored
2	No post-baseline assessments and no death	Date of randomization	Censored
3	No documented progression and no death (with a post-baseline tumor assessment)	Date of last adequate tumor assessment	Censored
4	Patient lost to follow-up (or withdrew consent from study participation) before documented progression or death	Date of last adequate tumor assessment	Censored
5	Documented progression	Date of documented progression.  If a tumor assessment was done on multiple days, use the earliest date for that visit.	Progressed
6	Death without documented progression	Date of death	Progressed
7	Documented progression or death after missing $\geq 2$ consecutive post-baseline tumor assessments	Date of last adequate tumor assessment before missed assessments or date of randomization, whichever is later.	Censored

Note: Progression-free survival and associated outcome is determined by the earliest of the dates above, if more than 1 situation applies.

The PFS analysis to test the superiority of abemaciclib plus NSAI to placebo plus NSAI in improving PFS time will use the stratified log-rank test stratified by nature of disease (visceral metastases vs. non-visceral metastases) and prior (neo)adjuvant endocrine therapy (prior therapy with disease-free interval > 12 months from completion of treatment vs. prior therapy with disease-free interval  $\leq$  12 months from completion of treatment vs. no prior therapy). The Kaplan-Meier method (Kaplan and Meier 1958) will be used to estimate the PFS curves, as well

as PFS rates at every 3 months for each treatment group. These rates will be compared based on a normal approximation for the difference between the rates.

A group-sequential design of the primary endpoint will be used to accommodate an event-driven plan for the interim and primary analysis. One interim analysis will be conducted by the DMC after approximately 119 (corresponding to 70% information rate) PFS events have been observed. The purpose of the interim analysis is to provide early efficacy information and allow for potential early communication with regulatory agencies. The O'Brien Fleming alpha spending function (Lan and DeMets 1983) will be used to preserve the overall type I error.

Therefore, if the interim analysis is performed after exactly 119 events have been observed, a 1-sided p-value of less than 0.0082 (corresponding approximately to an observed hazard ratio <0.627 under an exponential model) will need to be observed to declare statistical significance (see [Table JPBQ.12.2](#)).

**Table JPBQ.12.2. Properties of Design for Progression-Free Survival**

Information Fraction	Cumulative Events	Cumulative Alpha Spent	Cumulative Beta Spent	Boundary Reject $H_0$ (1-sided p-value)
0.70	119	0.0082	0	<0.0082
1	170	0.0250	0.2	<0.0223

The actual alpha spent will be calculated based on the actual number of events observed at the time of analysis using software that implements the alpha-spending function noted above (eg, ADDPLAN 6.0 or SAS 9.2).

If the interim analysis crosses the boundary of significance at the pre-specified level, the study is considered positive. If statistical significance is not declared at the interim, the final PFS analysis will be conducted with approximately 170 PFS events. All remaining alpha will be spent at the final analysis on Cohort A. Once statistical significance is declared at either interim analysis or the final analysis, the study is considered positive.

The Cox proportional hazard model (Cox 1972) with treatment as a factor will be used to estimate the hazard ratio and corresponding 95% CI with Wald's test p-value after stratifying for the same randomization variables specified for the primary analysis.

### **12.2.7. Secondary Outcomes and Methodology**

The secondary objectives of the study are listed in Section [6.2](#).

#### **12.2.7.1. Progression-Free Survival in Cohort B**

Progression-free survival in Cohort B is the key secondary endpoint for this study. The measurement, rules of censoring, and analysis methods of PFS in Cohort B are the same as those of PFS in Cohort A. Only if statistical significance is declared at the Cohort A interim analysis,

the interim analysis of Cohort B will be conducted based on the same data cutoff. No alpha specified for interim of Cohort B. If patients in Cohort A continue being followed for PFS until final analysis, the final analysis of Cohort B will be conducted at the same time of Cohort A final analysis. If Cohort A stops early at interim due to efficacy, the final analysis of Cohort B may be conducted after approximately 105 PFS events have been observed in Cohort B (that is, an approximately 30% censoring rate).

#### **12.2.7.2. Overall Survival**

Overall survival will be analyzed for each cohort. Overall survival time is measured from randomization until death from any cause. Patients who are alive will be censored at the data cut-off date of study completion. The final analysis of OS will be conducted together with the analysis of PFS at study completion.

Overall survival will be analyzed using the Kaplan-Meier method and the Cox proportional hazard model.

#### **12.2.7.3. Objective Response Rate, Disease Control Rate, Clinical Benefit Rate, and Duration of Response**

For each cohort, the objective response rate, DCR, and CBR of each treatment arm will be calculated as defined in Section 10.1.4 using the ITT population. All rates will be compared between treatment arms within the cohort based on a normal approximation for the difference between the rates.

The DoR time is defined only for responders (patients with a best response of CR or PR). It is measured from the date of first evidence of CR or PR to the date of objective progression or the date of death due to any cause, whichever is earlier. A Kaplan-Meier analysis of DoR will be performed to estimate the DoR curve for each arm in each cohort.

#### **12.2.8. Sensitivity Analysis**

Sensitivity analyses will be undertaken for calculation of the primary endpoint in order to evaluate the robustness of the analysis. Details can be found in the SAP.

#### **12.2.9. Pharmacokinetic and Pharmacodynamic Analyses**

Pharmacokinetics analyses will be conducted on all patients who have received at least 1 dose of study treatment and have had samples collected (see PK sampling schedule in [Attachment 7](#)).

Mean population PK parameters for abemaciclib and its metabolites in plasma (clearance, area under the plasma concentration versus time curve [AUC], volume of distribution, and half-lives) and inter-individual PK variability will be computed using nonlinear mixed-effect modeling implemented in NONMEM. Covariate effects (such as age, weight, sex, creatinine clearance, and plasma protein levels) on the PK parameters of abemaciclib and its metabolites in plasma will also be investigated.

Likewise, and if warranted by the data, mean population PK parameters for anastrozole, letrozole, or fulvestrant in plasma and inter-individual variability estimates will also be computed using nonlinear mixed-effect modeling implemented in NONMEM.

Finally, potential pharmacodynamic data (such as neutrophils, lymphocytes, or platelet counts in blood) collected in this study may be analyzed by means of NONMEM and connected to the population PK model for abemaciclib and/or NSAID or fulvestrant in a PK/PD model. Also, CTS associated with PFS and OS may be analyzed for exploratory objectives.

### **12.2.10. Biomarker Analyses**

Correlative analyses may be performed to investigate associations between biomarkers and clinical endpoints as deemed appropriate.

### **12.2.11. Health Outcome/Quality-of-Life Analyses**

Patient-reported outcomes are measured through paper versions of the following:

- EORTC QLQ-C30
- mBPI-sf

For each patient with data from baseline and at least 1 post-baseline visit, the maximum change from baseline score will be calculated and summarized for EORTC scale scores and mBPI-sf “worst pain.” The reason and number of missing and incomplete questionnaires/assessments by visit will be summarized for each instrument and study arm.

Further analysis details will be described in the SAP.

#### **12.2.11.1. Health-Related Quality of Life**

European Organization for Research and Treatment of Cancer Quality of Life Questionnaire-Core 30 instrument data will be scored as described by Aaronson and colleagues (Aaronson et al. 1993). If not already addressed in the EORTC scoring manual (Fayers et al. 2001), descriptive statistics for each EORTC QLQ-C30 item will be calculated. Descriptive statistics will be calculated for each dimension and the total score for each treatment arm in a cohort.

#### **12.2.11.2. Pain Intensity**

Individual pain items on the mBPI-sf (ie, worst, least, average, and current pain) will be described using descriptive statistics (eg, n, mean, median, standard deviation, minimum, and maximum) by treatment arm and time points. A mixed effects model, repeated measures model may be applied to compare between treatment arms, which may be adjusted for other covariates. Corresponding analyses will also be conducted for the mean of 7 pain interference with function items. If a patient does not complete Questions 5a through 5g on the mBPI-sf, the mean score for the 7 pain interference items will be calculated based on those answered questions when at least 4 out of 7 questions were completed (ie,  $\geq 50\%$  of the questions were answered). Separate similar analyses will be conducted using the average of the mBPI-sf/worst pain assessments associated with each cycle.

Pain analysis will be based on all randomized patients with at least 1 baseline mBPI-sf “worst pain” and 1 mBPI-sf “worst pain” score on Cycle 2 Day 1 or later.

The mBPI-sf will be administered at baseline prior to study drug dosing and the Cycle 1, Day 1 score will be treated as a baseline observation and the Day 1 score of each subsequent cycle will be attributed to the previous cycle. The mBPI-sf will be administered at treatment discontinuation and grouped with observations from the previous cycle.

Time to worsening in pain will be described using the Kaplan-Meier method and will be made between the 2 treatment arms by a log-rank test. “Worsening” will be defined as either a “worst pain” increase of  $\geq 2$  points postbaseline or an analgesic drug class increase of  $\geq 1$  level. Worsening rate at Years 1, 2, and 3 will be estimated and compared between the 2 treatment arms within each cohort. The number of events due to each criterion will be described.

### **12.2.11.3. Resource Utilization**

Utilization data will be summarized descriptively by category across arms in a cohort (eg, analgesic use, bisphosphonate use, transfusions, radiation, surgery, and hospitalization days), including a frequency table with tabular statistics. Tests for differences in proportions between treatment groups and between response groups will be performed.

### **12.2.12. Safety Analyses**

All safety summaries and analyses will be based upon the Safety Population as defined in Section [12.2.1](#).

Overall exposure to study drug, the numbers of patients completing each cycle, and the dose intensity will be summarized using descriptive statistics. The number of patients with any dose adjustment will be presented for the entire treatment period as well as for each cycle. The number of patients with dose reductions, delays, or omissions will also be summarized, as will the reasons for dose adjustments.

Adverse events will be reported using MedDRA. Investigators will report a verbatim AE term and a CTCAE v4.0 term and severity for all AEs. For analysis purposes, the following process will be used:

- The CTCAE v4.0 term reported by the investigator will be mapped to the MedDRA Preferred Term (PT) and SOC using the corresponding MedDRA Lower Level Term (LLT), unless the reported CTCAE term is ‘Other – specify.’
- If the reported CTCAE term is ‘Other – specify,’ the MedDRA LLT, PT, and SOC centrally mapped from the verbatim AE term will be used.
- All listings and summaries will use the PT resulting from this process.

Preexisting conditions are defined as AEs that begin prior to the first dose of study drug.

A TEAE is defined as an event that first occurred or worsened in severity after baseline. Comparisons of preexisting conditions to on-treatment events at the LLT level will be used in the treatment-emergent computation.



The following summaries will be produced by PT within SOC: preexisting conditions, SAEs, TEAEs, drug-related TEAEs, and procedure-related TEAEs.

The following summaries will be produced by PT within SOC and maximum CTCAE grade: laboratory-based TEAEs, nonlaboratory-based TEAEs, drug-related laboratory-based TEAEs, and drug-related nonlaboratory-based TEAEs.

Reasons for death will be summarized separately for on-therapy and within 30 days of treatment discontinuation.

Hospitalizations and transfusions during the study treatment period or during the 30-day short-term follow-up period will be summarized by treatment group.

### **12.2.13. Subgroup Analyses**

Subgroup analyses of PFS will be performed for potential prognostic subgroup variables within each cohort, including:

- All baseline stratification factors
- NSAI received for Cohort A while on study (letrozole vs. anastrozole)
- Study entry disease status (de novo metastatic vs. recurrent metastatic vs. locoregionally recurrent)
- Measurable disease at baseline (yes vs. no)
- Number of organs involved (1 vs. 2 vs. 3+)
- Age (<65 years vs. ≥65 years)
- Country (China vs. Other)
- Race (Asian vs. Other)
- PgR status (positive vs. negative)
- Baseline ECOG PS (0 vs. 1)

If a level of a factor consists of fewer than 5% of total randomized patients in the study, analysis within that level may be omitted. The final list of subgroup analyses will be provided in the SAP.

Analyses will be done within subgroups and, separately, across subgroups with a test of interactions of subgroups with treatment performed.

Other subgroup analyses may be performed as deemed appropriate.

### **12.2.14. Interim Analysis and Other Planned Analyses**

An interim analysis on Cohort A will be conducted by the DMC after approximately 119 PFS events have been observed. The interim analysis will be conducted to provide early efficacy information and could potentially result in early communication with regulatory agencies. The O'Brien Fleming alpha spending function (Lan and DeMets 1983) will be used to preserve the overall type I error. If the analysis of PFS is significant using the cutoff described in Section 12.2.6, the DMC will be instructed to engage the SMD, who may subsequently convene an IRC to propose actions based upon the DMC's recommendation. All patients will continue

follow-up for PFS until study completion, and will remain blinded for the duration of the study unless emergency unblinding (Section 9.5.2) are met. If Cohort A show early efficacy at interim, the sponsor may consider early stop, unblinding and crossover for this cohort; however, regulatory agencies will be consulted before any action is taken.

The unblinded analysis, including review of the efficacy along with the safety data, will be conducted by the DMC. Only the DMC is authorized to evaluate unblinded interim efficacy and safety analyses. Study sites will receive information about interim results ONLY if they need to know for the safety of their patients.

If statistical significance is not declared at the interim, a final analysis of Cohort A will be conducted with about 170 PFS events.

The interim analysis of Cohort B is triggered only if statistical significance is declared at the Cohort A interim analysis. No DMC is required for the analysis of Cohort B. The analysis will provide both safety and efficacy information of Cohort B and could potentially result in early communication with regulatory agencies, including consultation of potential decisions regarding early stop, unblinding and crossover before any action is taken.

In the case of early stop and crossover for Cohort A or Cohort B after the interim analysis, Lilly will notify investigators when the crossover begins.

If patients in Cohort A continue being followed for PFS until final analysis, the final analysis of Cohort B will be conducted at the same time of Cohort A final analysis. If Cohort A stops early at interim due to efficacy, the final analysis of Cohort B may be conducted after approximately 105 PFS events have been observed in Cohort B.

Unblinding details are specified in the unblinding plan section of the SAP.

## 13. Informed Consent, Ethical Review, and Regulatory Considerations

### 13.1. Informed Consent

The investigator is responsible for ensuring that the patient understands the potential risks and benefits of participating in the study, including answering any questions the patient may have throughout the study and sharing in a timely manner any new information that may be relevant to the patient's willingness to continue his or her participation in the trial.

The ICF will be used to explain the potential risks and benefits of study participation to the patient in simple terms before the patient is entered into the study, and to document that the patient is satisfied with his or her understanding of the risks and benefits of participating in the study and desires to participate in the study.

The investigator is responsible for ensuring that informed consent is given by each patient or, where permitted by local law or regulation, by the patient's legal representative. This includes obtaining the appropriate signatures and dates on the ICF prior to the performance of any protocol procedures and prior to the administration of study drug.

As used in this protocol, the term "informed consent" includes all consent and assent given by patients or their legal representatives.

### 13.2. Ethical Review

Lilly or its representatives must approve all ICFs before they are used at the investigative sites. All ICFs must be compliant with the ICH guideline on GCP.

Documentation of ERB approval of the protocol and the ICF must be provided to Lilly before the study may begin at the investigative sites.

The study site's ERBs should be provided with the following:

- the current IB or package labeling and updates during the course of the study
- the ICF
- relevant curricula vitae.

### 13.3. Regulatory Considerations

This study will be conducted in accordance with:

- consensus ethics principles derived from international ethics guidelines, including the Declaration of Helsinki and Council for International Organizations of Medical Sciences International Ethical Guidelines
- International Conference on Harmonisation (ICH) GCP Guideline (E6)
- applicable laws and regulations.

The investigator or designee will promptly submit the protocol to applicable ERB(s).

Some of the obligations of Lilly will be assigned to a third-party organization (TPO).

An identification code assigned by the investigator to each patient will be used in lieu of the patient's name to protect the patient's identity when reporting AEs and/or other trial-related data.

### **13.3.1. Investigator Information**

Site-specific contact information may be provided in a separate document.

Physicians with a specialty in oncology will participate as investigators in this clinical trial.

### **13.3.2. Protocol Signatures**

The sponsor's responsible medical officer will approve the protocol, confirming that, to the best of his or her knowledge, the protocol accurately describes the planned design and conduct of the study.

After reading the protocol, each principal investigator will sign the protocol signature page and send a copy of the signed page to a Lilly representative.

### **13.3.3. Final Report Signature**

The CSR coordinating investigator will sign the final CSR for this study, indicating agreement that, to the best of his or her knowledge, the report accurately describes the conduct and results of the study.

Lilly will select an investigator to serve as the CSR coordinating investigator.

The Lilly responsible medical officer and statistician will sign/approve the final CSR for this study, confirming that, to the best of his or her knowledge, the report accurately describes the conduct and results of the study.

## 14. References

- Aaronson NK, Ahmedzai S, Bergman B, Bullinger M, Cull A, Duez NJ, Filiberti A, Flechtner H, Fleishman SB, de Haes JC, Kaasa S, Klee M, Osoba D, Razavi D, Rofe PB, Schraub S, Sneeuw K, Sullivan M, Takeda F. The European Organization for Research and Treatment of Cancer QLQ-C30: a quality-of-life instrument for use in international clinical trials in oncology. *J Natl Cancer Inst.* 1993;85(5):365-376.
- Bray F, Ren JS, Masuyer E, Ferlay J. Global estimates of cancer prevalence for 27 sites in the adult population in 2008. *Int J Cancer.* 2013;132(5):1133-1145.
- Cardoso F, Costa A, Norton L, Cameron D, Cufer T, Fallowfield L, Francis P, Gligorov J, Kyriakides S, Lin N, Pagani O, Senkus E, Thomssen C, Aapro M, Bergh J, Di Leo A, El Saghir N, Ganz PA, Gelmon K, Goldhirsch A, Harbeck N, Houssami N, Hudis C, Kaufman B, Leadbeater M, Mayer M, Rodger A, Rugo H, Sacchini V, Sledge G, van't Veer L, Viale G, Krop I, Winer E. 1st International consensus guidelines for advanced breast cancer (ABC 1). *Breast.* 2012;21(3):242-252.
- Casimiro MC, Velasco-Velazquez M, Aguirre-Alvarado C, Pestell RG. Overview of cyclins D1 function in cancer and the CDK inhibitor landscape: past and present. *Expert Opin Investig Drugs.* 2014; 23(3):295-304.
- Cleeland CS. Pain assessment in cancer. In: Osoba D, editor. Effect of cancer on quality of life. Boca Raton (FL): CRC Press; 1991:p 293-305.
- Cox DR. Regression models and life-tables. *J Royal Stat Soc Ser B.* 1972;34(2):187-220.
- Eisenhauer EA, Therasse P, Bogaert J, Schwartz LH, Sargent D, Ford R, Dancey J, Arbuck S, Gwyther S, Mooney M, Rubinstein L, Shankar L, Dodd L, Kaplan R, Lacombe D, Verweij J. New response evaluation criteria in solid tumours: revised RECIST guideline (version 1.1). *Eur J Cancer.* 2009;45(2) 228-247.
- Fayers PM, Aaronson NK, Bjordal K, Groenvold M, Curran D, Bottomley A, on behalf of the EORTC Quality of Life Group. The EORTC QLQ-C30 Scoring Manual. 3rd edition. Brussels: European Organisation for Research and Treatment of Cancer, Brussels; 2001.
- Ferlay J, Soerjomataram I, Ervik M, Dikshit R, Eser S, Mathers C, Rebelo M, Parkin DM, Forman D, Bray, F. GLOBOCAN 2012 v1.0, Cancer Incidence and Mortality Worldwide: IARC CancerBase No. 11. Lyon, France: International Agency for Research on Cancer. Available at: <http://globocan.iarc.fr>. Accessed January 19, 2016.
- Hammond ME, Hayes DF, Dowsett M, Allred DC, Hagerty KL, Badve S, Fitzgibbons PL, Francis G, Goldstein NS, Hayes M, Hicks DG, Lester S, Love R, Mangu PB, McShane L, Miller K, Osborne CK, Paik S, Perlmutter J, Rhodes A, Sasano H, Schwartz JN, Sweep FC, Taube S, Torlakovic EE, Valenstein P, Viale G, Visscher D, Wheeler T, Williams RB, Wittliff JL, Wolff AC. American Society of Clinical Oncology/College of American Pathologists guideline recommendations for immunohistochemical testing of estrogen and progesterone receptors in breast cancer [published correction appears in *J Clin Oncol.* 2010;28(21):354]. *J Clin Oncol.* 2010;28(16):2784-2795.
- Kaplan EL, Meier P. Nonparametric estimation of incomplete observations. *J Amer Stat Assoc.* 1958;53(282):457-481.

- Lan KKG, DeMets DL. Discrete sequential boundaries for clinical trials. *Biometrika*. 1983;70(3):659-663.
- Oken MM, Creech RH, Tormey DC, Horton J, Davis TE, McFadden ET, Carbone PP. Toxicity and response criteria of the Eastern Cooperative Oncology Group. *Am J Clin Oncol*. 1982;5(6):649-655.
- Ortega S, Malumbres M, Barbacid M. Cyclin-D dependent kinases INK4 inhibitors and cancer. *Biochim Biophys Acta*. 2002;1602(1):73-87.
- Sherr CJ. Cancer cell cycles. *Science*. 1996;274(5293):1672-1677.
- Smith TJ, Bohlke K, Lyman GH, Carson KR, Crawford J, Cross SJ, Goldberg JM, Khatcheressian JL, Leighl NB, Perkins CL, Somlo G, Wade JL, Wozniak AJ, Armitage JO; American Society of Clinical Oncology. Recommendations for the use of WBC growth factors: American Society of Clinical Oncology Clinical Practice Guideline Update. *J Clin Oncol*. 2015;33(28):3199-3212.
- Velasco-Velazquez MA, Li Z, Casimiro M, Loro E, Homsy N, Pestell RG. Examining the role of cyclin D1 in breast cancer. *Future Oncol*. 2011;7(6):753-765.
- Wolff AC, Hammond ME, Hicks DG, Dowsett M, McShane LM, Allison KH, Allred DC, Bartlett JM, Bilous M, Fitzgibbons P, Hanna W, Jenkins RB, Mangu PB, Paik S, Perez EA, Press MF, Spears PA, Vance GH, Viale G, Hayes DF; American Society of Clinical Oncology; College of American Pathologists. Recommendations for human epidermal growth factor receptor 2 testing in breast cancer: American Society of Clinical Oncology/College of American Pathologists clinical practice guideline update. *J Clin Oncol*. 2013;31(31):3997-4013.

---

**Attachment 1. Protocol JPBQ Study Schedule**

---

Study Schedule, Protocol I3Y-CR-JPBQ

Perform procedure as indicated.

		Baseline		Patients on Study Treatment							Postdiscontinuation Follow-Up		
		BL		1	2			3	4 – X		Short-Term Follow-Up <sup>a</sup>	Long-Term Follow-Up <sup>a</sup>	
		0		1	2			3	4 – X		801	802 - 8XX	
		≤28	≤14	1	15 ± 3	1 <sup>b</sup>	15 ± 3	last 7 days	1 <sup>b</sup>	1 <sup>b</sup>	last 7 days		
Procedure Category	Procedure	Protocol Reference											
Study Entry/ Enrollment	Informed Consent Form signed (prior to performance of any protocol-specific tests/procedures) <sup>c</sup>	Section 8.1		X <sup>c</sup>									
	Inclusion/Exclusion evaluation	Section 7			X								
Medical History	Initial history/preexisting conditions/ previous treatment	Section 12.2.3			X								
Physical Examination (Obtain prior to drug administration for on-therapy cycles)	Height	Section 12.2.3			X								
	Weight	Section 12.2.3			X	X		X		X	X		X
	Vital Signs (Temp, BP, HR, RR)	Section 12.2.3			X	X		X		X	X		X
	ECOG performance status	Section 7.1 Attachment 4			X	X		X		X	X		X
Tumor Assessment	Tumor measurement (palpable or visible) <sup>d</sup>	Section 10.1.1			X <sup>d</sup>				X <sup>d</sup>	X <sup>d</sup>		X <sup>d</sup>	X <sup>d</sup>
	Radiologic imaging according to RECIST <sup>e</sup>	Section 10.1.1 Attachment 5			X <sup>e</sup>				X <sup>e</sup>		X <sup>e</sup>	X <sup>e</sup>	X <sup>e</sup>
	Bone Scintigraphy <sup>f</sup>	Section 10.1.1 Attachment 5			X <sup>f</sup>						X <sup>f</sup>	X <sup>f</sup>	X <sup>f</sup>
	X-ray, or CT scan with bone windows, or MRI <sup>g</sup>	Section 10.1.1 Attachment 5			X <sup>g</sup>				X <sup>g</sup>		X <sup>g</sup>	X <sup>g</sup>	X <sup>g</sup>
Randomization <sup>h</sup>	Section 9.3			X <sup>h</sup>									
Survival information <sup>i</sup>	Section 10.1										X <sup>i</sup>	X <sup>i</sup>	



		Baseline	Patients on Study Treatment								Postdiscontinuation Follow-Up			
		BL	1	2			3	4 – X		Short-Term Follow-Up <sup>a</sup>	Long-Term Follow-Up <sup>a</sup>			
		0	1	2			3	4 – X		801	802 - 8XX			
		≤28	≤14	1	15±3	1 <sup>b</sup>	15±3	last 7 days	1 <sup>b</sup>	1 <sup>b</sup>	last 7 days			
Procedure Category	Procedure	Protocol Reference												
<b>Adverse Event Collection/CTCAE Grading<sup>j</sup></b>		<b>Section 10.3</b>		X <sup>j</sup>	X <sup>j</sup>	X <sup>j</sup>			X <sup>j</sup>	X <sup>j</sup>		X <sup>j</sup>	X <sup>j</sup>	
<b>Concomitant Medication Notation</b>		<b>Section 9.6</b>		X	X	X			X	X		X		
<b>Study Diaries</b>	Dispense Study Diaries	<b>Section 9.7.1</b>			X	X			X	X				
	Review/Collect Study Diaries	<b>Section 9.7.1</b>				X			X	X		X		
<b>Lab/ Diagnostic Tests</b>	Central hematology <sup>k</sup>	<b>Attachment 2</b>			X <sup>k</sup>	X <sup>k</sup>	X <sup>k</sup>	X <sup>k</sup>	X <sup>k</sup>	X <sup>k</sup>		X <sup>k</sup>		
	Central chemistry <sup>k</sup>	<b>Attachment 2</b>			X <sup>k</sup>	X <sup>k</sup>	X <sup>k</sup>	X <sup>k</sup>	X <sup>k</sup>	X <sup>k</sup>		X <sup>k</sup>		
	Local FSH and estradiol levels <sup>l</sup>	<b>Attachment 2</b>			X <sup>l</sup>									
	Central pharmacokinetic (PK) sampling <sup>m</sup>	<b>Attachment 7</b>				X <sup>m</sup>		X <sup>m</sup>		X <sup>m</sup>	X <sup>m</sup>			
	Pharmacogenetic whole blood sampling <sup>n</sup>	<b>Section 10.4.2.1</b>				X <sup>n</sup>								
	Biomarker plasma sample <sup>o</sup>	<b>Section 10.4.2.2</b>				X <sup>o</sup>		X <sup>o</sup>					X <sup>o</sup>	
	Local ECG <sup>p</sup>	<b>Section 10.3.2.1</b>			X <sup>p</sup>								X <sup>p</sup>	
<b>Study Treatment</b>	Abemaciclib/Placebo <sup>q</sup>		<b>Section 9.1</b>		Q12H on Days 1 through 28 of every cycle <sup>q</sup>									
	Cohort A	Anastrozole <sup>q</sup>	<b>Section 9.1</b>		Take 1 mg tablet orally Q24H on Days 1 through 28 <sup>q</sup>									
		Letrozole <sup>q</sup>	<b>Section 9.1</b>		Take 2.5 mg tablet orally Q24H on Days 1 through 28 <sup>q</sup>									
	Cohort B	Fulvestrant <sup>q</sup>	<b>Section 9.1</b>		Days 1 and 15 of Cycle 1, then Day 1 of Cycle 2 and beyond <sup>q</sup>									
<b>Health Outcomes</b>	EORTC QLQ-C30 , mBPI-sf <sup>r</sup>		<b>Section 12.2.11</b>			X <sup>r</sup>		X <sup>r</sup>		X <sup>r</sup>	X <sup>r</sup>		X <sup>r</sup>	
	Hospitalization		<b>Section 12.2.11.3</b>				X		X		X	X	X	
	Transfusion		<b>Section 12.2.11.3</b>				X		X		X	X	X	

Abbreviations: BL = baseline; BP = blood pressure; CT = computed tomography; CTCAE = Common Terminology Criteria for Adverse Events; ECG = electrocardiogram; ECOG = Eastern Cooperative Oncology Group; EORTC QLQ-C30 = European Organization for Research and Treatment of Cancer Quality of Life Questionnaire-Core 30; FSH = follicular stimulating hormone; HR = heart; IV = intravenous; mBPI-sf = modified Brief Pain Inventory short form; MRI = magnetic resonance imaging; NSAI = nonsteroidal aromatase inhibitor; PD = progressive disease; PK = pharmacokinetics; Q12H = every 12 hours; Q24H = every 24 hours; RECIST = Response Evaluation Criteria in Solid Tumors; RR = respiratory rate; SAE = serious adverse event; temp = temperature.

- a Short-term follow-up begins the day after the patient and the investigator agree that the patient will no longer continue study drug and lasts approximately 30 days ( $\pm 7$  days); the associated study procedures are performed once at the end of this period. Long-term follow-up begins the day after short-term follow-up is completed and continues until the patient's death or overall study completion; the associated study procedures are performed approximately every 12 weeks ( $\pm 14$  days) for the duration of this period.
- b For Cycle 2 and beyond, the start of a cycle may be delayed up to 7 days for logistical reasons and up to 14 days to allow sufficient time for recovery from toxicity possibly related to a study drug. Refer to Section 9.4.1.1.2.
- c Informed consent form is signed within 28 days prior to randomization of study drug and prior to performance of any protocol-specific tests/procedures.
- d Visible tumor (such as skin lesions) identified at baseline require repeat photographic images on Day 1 of every second cycle beginning with Cycle 3 and continuing through Cycle 19 (inclusive), on Day 1 of every third cycle after Cycle 19, and within 14 days of clinical progression. Photographic images may be taken more frequently based upon the discretion of the investigator or following the identification of new skin lesions post-baseline. Each photographic image of the tumor should include a ruler if applicable. For patients who discontinue study treatment without objectively measured PD, continue to evaluate tumor response approximately every 8 weeks for the first 12 months following randomization and thereafter approximately every 12 weeks by the same method used at baseline and throughout the study, until the patient has objective disease progression or until study completion. After the patient has objective disease progression, tumor assessments are no longer required and the patient will continue with post-discontinuation follow-up until the patient's death or overall study completion. Assessments should be performed prior to dosing at the beginning of the required cycle unless otherwise indicated.
- e For patients with inoperable locoregionally recurrent breast cancer, MRI scan of the breast is performed locally at baseline (Day -28 to Day -1), in the last 7 days of every second cycle beginning with Cycle 2 and continuing through Cycle 18, in the last 7 days of every third cycle after Cycle 18, and within 14 days of clinical progression. For all patients, CT or MRI scan of the chest, abdomen, and pelvis is performed locally at baseline (Day -28 to Day -1), in the last 7 days of every second cycle beginning with Cycle 2 and continuing through Cycle 18, in the last 7 days of every third cycle after Cycle 18, and within 14 days of clinical progression. It is recommended that CT imaging of the abdomen and pelvis be performed with IV contrast whenever possible. If this is not feasible due to hypersensitivity or other conditions, then gadolinium-enhanced MRI is preferred. For patients with known serious allergic reactions to CT contrast material, a CT of the chest without contrast and gadolinium-enhanced MRI of the abdomen/pelvis are encouraged. For patients who discontinue study treatment without objectively measured PD, continue to evaluate tumor response approximately every 8 weeks for the first 18 months following randomization and thereafter approximately every 12 weeks by the same method used at baseline and throughout the study until the patient has objective disease progression or until study completion. After the patient has objective disease progression, radiologic tests are no longer required and the patient will continue with post-discontinuation follow-up until the patient's death or overall study completion. Assessments should be performed prior to dosing at the beginning of the required cycle unless otherwise indicated.
- f Bone scintigraphy is performed locally at baseline (Day -28 to Day -1) for all patients. If available, prior bone scintigraphy (obtained as part of routine clinical care) within 45 days before Cycle 1, Day 1 is also acceptable. Bone scintigraphy should be repeated for all patients between last 7 days of every sixth

cycle beginning with Cycle 6, when complete response is identified in target disease, or when progression in bone is suspected. Importantly, RECIST v1.1 emphasizes that bone scintigraphy is not adequate to measure bone lesions; however, bone scintigraphy can be used to confirm the presence or disappearance of bone lesions. For patients who discontinue study treatment without objectively measured progressive disease (PD), continue to evaluate tumor response approximately every 6 months until the patient has objective disease progression or until study completion. After the patient has objective disease progression, bone scintigraphy is no longer required and the patient will continue with post-discontinuation follow-up until the patient's death or overall study completion. Assessments should be performed prior to dosing at the beginning of the required cycle unless otherwise indicated.

- g One or more of these studies [X-ray, CT scan with bone windows, or MRI] is performed locally at baseline (Day -28 to Day -1), in the last 7 days of every second cycle beginning with Cycle 2 and continuing through Cycle 18, in the last 7 days of every third cycle after Cycle 18, and within 14 days of clinical progression only for patients with bone lesions identified by bone scintigraphy at baseline. For patients with new lesions identified by post-baseline bone scintigraphy, targeted assessment by X-ray, CT scan with bone windows, or MRI will be performed to confirm findings. For patients who discontinue study treatment without objectively measured progressive disease (PD), continue to evaluate tumor response approximately every 8 weeks for the first 12 months following randomization and thereafter approximately every 12 weeks by the same method used at baseline and throughout the study until the patient has objective disease progression or until study completion. After the patient has objective disease progression, radiologic tests are no longer required and the patient will continue with post-discontinuation follow-up until the patient's death or overall study completion. Assessments should be performed prior to dosing at the beginning of the required cycle unless otherwise indicated.
- h The period between randomization to blinded study drug and the first dose (Cycle 1, Day 1) should not exceed 7 days.
- i Although preferable to collect during a clinic visit, survival information may be collected by contacting the patient or family directly (eg, via telephone) if no procedures are required. This should be collected at minimum every 90 days if no other procedures are performed. Additional long-term follow-up data collection will include postdiscontinuation anticancer therapies.
- j Data on SAEs that occur before the end of trial will be stored in the collection database and the Lilly Safety System. During long-term follow-up, only SAEs that are related to study drugs or protocol procedures will be collected. All adverse events possibly related to study drugs or protocol procedures should be followed until they resolve, are no longer considered to be possibly related, become stable or return to baseline, the patient starts a new therapy, the patient expires, or the patient becomes lost to follow-up. The frequency of evaluation is determined according to the judgment of the investigator.
- k Central hematology/central chemistry labs can be drawn up to 5 days prior to Day 1 of each cycle. Local hematology/local chemistry during the cycle can be performed for treatment decisions at the discretion of the investigator. If the treatment was suspended due to hematologic/non-hematologic toxicity, the decision to perform hematology and/or chemistry labs before re-initiation of the blinded study drug is at the discretion of the investigator. Assessments should be performed prior to dosing at the beginning of the required cycle unless otherwise indicated.
- l FSH and estradiol levels are required only for women age <60 years and amenorrheic for at least 12 months.
- m See PK Sampling Schedule ([Attachment 7](#)).
- n Draw sample before patient is dosed on Cycle 1, Day 1
- o During the treatment study, draw sample for all patients before dosed on Cycle 1, Day 1 and upon arrival at site on Cycle 2, Day 1. During the short-term follow-up period, draw sample only for patients discontinuing due to PD.
- p A local ECG (no replicates required) should be obtained at baseline (Day -14 to Day -1), and at the short-term follow-up visit. Patients must be resting for approximately 5 to 10 minutes before ECG collection and remain supine but awake during ECG collection.
- q Blinded study drug should be administered orally Q12H on Days 1 through 28 of each cycle; For patients in Cohort A, on Cycle 2, Day 1, patients will take

NSAI and blinded study drug at home at least 4 hours prior to arrival at the clinic. For PK purposes, NSAI should be administered at the same time (or up to 20 minutes after) the first dose of blinded study drug through Cycle 4, Day 1. Subsequently, the interval between administration of blinded study drug and NSAI may be adjusted based on the judgment of the investigator. For patients in cohort B, on Cycle 2 Day 1, patients will take the blinded study drug at home at least 4 hours prior to arrival at the clinic. For PK purposes, fulvestrant should be administered at the same time as (or up to 20 minutes after) the first dose of blinded study drug, except when specified otherwise in the PK Sampling Schedule ([Attachment 7](#)) through Cycle 4 Day 1. Subsequently, the interval between administration of blinded study drug and fulvestrant may be adjusted based on the judgment of the investigator. Fulvestrant 500 mg should be administered intramuscularly into the buttocks slowly (1 to 2 minutes per injection) as two 250-mg injections, one in each buttock; however, for patients with moderate hepatic impairment (defined as Child-Pugh Class B), including any patient who develops moderate hepatic impairment during study treatment, fulvestrant 250 mg should be administered intramuscularly into the buttock slowly (1 to 2 minutes) as one 250-mg injection.

- r EORTC QLQ-C30, mBPI-sf should be administered twice at baseline (Day -14 to Day -1, and at C1D1), Cycle 2 Day 1, and then on Day 1 of every second cycle beginning with Cycle 3 and continuing through Cycle 13, on Day 1 of every third cycle after Cycle 13, and at Short-Term Follow-Up. Patients should complete these assessments before extensive interaction with site staff.

**Study Schedule for the Continued Access Period Only, Protocol I3Y-CR-JPBQ**

Perform procedure as indicated.

		Patients on Study Treatment	Continued Access Follow-Up
<b>Cycle</b>		X-Y	Follow-Up <sup>a</sup>
<b>Visit</b>		501-5XX	901
<b>Approximate Visit Duration (days)</b>		28	30±5
<b>Relative day within a cycle</b>		1	
Procedure Category	Procedure	Protocol Reference	
<b>Adverse Events Collection/CTCAE Grading<sup>b</sup></b>		<b>Section 10.3</b>	X
<b>Study Treatment</b>	Abemaciclib <sup>c</sup>	<b>Section 9.1</b>	Daily Q12H <sup>c</sup>
	Cohort A	Anastrozole <sup>c</sup>	<b>Section 9.1</b>
		Letrozole <sup>c</sup>	<b>Section 9.1</b>
	Cohort B	Fulvestrant <sup>c</sup>	<b>Section 9.1</b>

Abbreviations: CTCAE = Common Terminology Criteria for Adverse Events; SAE= serious adverse event; Q12H = every 12 hours, Q24H = every 24 hours.

- a The continued access period begins after study completion and ends at the end of trial.
- b Data on SAEs that occur before the end of trial will be stored in the collection database and the Lilly Safety System.
- c Abemaciclib/placebo should be administered Q12H on Days 1 through 28 of each cycle. Anastrozole or letrozole should be administered Q24H on Days 1 through 28 of each cycle. Patients receiving clinical benefits will continue to receive anastrozole or letrozole during the continued access period. Fulvestrant 500 mg should be administered intramuscularly into the buttocks slowly (1 to 2 minutes per injection) as two 250-mg injections, one in each buttock; however, for patients with moderate hepatic impairment (defined as Child-Pugh Class B), including any patient who develops moderate hepatic impairment during study treatment, fulvestrant 250 mg should be administered intramuscularly into the buttock slowly (1 to 2 minutes) as one 250-mg injection.

---

## Attachment 2. Protocol JPBQ Clinical Laboratory Tests

---

### Clinical Laboratory Tests

---

#### Hematology<sup>a</sup>:

Hemoglobin

Hematocrit

Erythrocyte count (RBC)

Mean cell volume (MCV)

Mean cell hemoglobin concentration (MCHC)

Leukocytes (WBC)

Neutrophils

Lymphocytes

Monocytes

Eosinophils

Basophils

Platelets

#### Clinical Chemistry<sup>a</sup>:

##### Serum Concentrations of:

Sodium

Chloride

Potassium

Total bilirubin

Direct bilirubin

Alkaline phosphatase

Alanine aminotransferase (ALT)

Aspartate aminotransferase (AST)

Blood urea nitrogen (BUN)

Creatinine

Calcium

Total Protein

Albumin

Cholesterol<sup>b</sup>FSH level<sup>c,d</sup>Estradiol level<sup>c,d</sup>

---

Abbreviations: FSH = follicle-stimulating hormone; RBC = red blood cells; WBC = white blood cells.

a Lilly-designated (central) laboratory.

b Per the letrozole and anastrozole labels, investigators should consider monitoring cholesterol (local or central laboratory). The decision to monitor and frequency of monitoring are at the discretion of the investigator.

c Local or investigator-designated laboratory.

d To be performed at baseline only in order to establish eligibility. Follicle-stimulating hormone and estradiol levels are required only for women age <60 years and amenorrheic for at least 12 months.

---

## Attachment 3. Protocol JPBQ Hepatic Monitoring Tests for Treatment-Emergent Abnormality

---

Selected tests may be obtained in the event of a treatment-emergent hepatic abnormality and may be required in follow up with patients in consultation with the Lilly clinical research physician.

### Hepatic Monitoring Tests

---

#### Hepatic Hematology<sup>a</sup>

Hemoglobin  
Hematocrit  
RBC  
WBC  
Neutrophils  
Lymphocytes  
Monocytes  
Eosinophils  
Basophils  
Platelets

#### Hepatic Chemistry<sup>a</sup>

Total bilirubin  
Direct bilirubin  
Alkaline phosphatase  
ALT  
AST  
GGT  
CPK

#### Haptoglobin<sup>a</sup>

#### Hepatic Coagulation<sup>a</sup>

Prothrombin Time  
Prothrombin Time, INR

#### Hepatic Serologies<sup>a,b</sup>

Hepatitis A antibody, total  
Hepatitis A antibody, IgM  
Hepatitis B surface antigen  
Hepatitis B surface antibody  
Hepatitis B Core antibody  
Hepatitis C antibody  
Hepatitis E antibody, IgG  
Hepatitis E antibody, IgM

#### Anti-nuclear antibody<sup>a</sup>

#### Anti-smooth muscle antibody<sup>a</sup>

---

Abbreviations: ALT = alanine aminotransferase; AST = aspartate aminotransferase; CPK = creatine phosphokinase; GGT = gamma glutamyl transferase; Ig = immunoglobulin; INR = international normalized ratio; RBC = red blood cells; WBC = white blood cells.

<sup>a</sup> Assayed by Lilly-designated laboratory.

<sup>b</sup> Reflex/confirmation dependent on regulatory requirements and/or testing availability.

---

**Attachment 4. Protocol JPBQ ECOG Performance Status**

---

**ECOG Performance Status**

Activity Status	Description
0	Fully active, able to carry on all pre-disease performance without restriction
1	Restricted in physically strenuous activity but ambulatory and able to carry out work of a light or sedentary nature, e.g., light house work, office work
2	Ambulatory and capable of all self-care but unable to carry out any work activities. Up and about more than 50% of waking hours
3	Capable of only limited self-care, confined to bed or chair more than 50% of waking hours
4	Completely disabled. Cannot carry on any self-care. Totally confined to bed or chair
5	Dead

---

Abbreviation: ECOG = Eastern Cooperative Oncology Group.

Source: Oken et al. 1982.



CCI

CCI

CCI

CCI

CCI

CCI

CCI

## Attachment 6. Protocol JPBQ Sampling Summary

This table summarizes the purpose for sampling, sample types, maximum volume per sample, maximum number of samples, and maximum total volume during the study. The summary below provides estimates. More samples could be required in the case of retests, additional health monitoring (if needed), or for patients continuing treatment beyond the protocol-specified number of cycles in the study. Fewer samples may actually be taken (eg, patients who discontinue from the study).

### Protocol I3Y-MC-JPBQ Sampling Summary<sup>a</sup>

Purpose	Sample Type	Maximum Amount per Sample	Maximum Number Samples	Maximum Total Amount
Screening/Study qualification (Hematology and Clinical Chemistry)	Blood	7 mL	1	7 mL
Safety/Health monitoring (Hematology and Clinical Chemistry)	Blood	7 mL	20	140 mL
Pharmacokinetic sample	Blood	4 mL	5	20 mL
Pharmacogenetic blood sample	Blood	10 mL	1	10 mL
Biomarker plasma sample	Blood	6 mL	3	18 mL
Total blood volume	Blood			195 mL
Hepatic monitoring <sup>b</sup>	Blood	3 - 30 mL	-	-

<sup>a</sup> Covers Cycles 1 through 16 and 1 postdiscontinuation follow-up visit.

<sup>b</sup> Based on laboratory safety values, unscheduled hepatic monitoring testing may be performed as part of patient follow-up, in consultation with the designated medical monitor.



## Attachment 7. Protocol JPBQ Pharmacokinetic Sampling Schedule

The schedule for PK sampling is summarized in the table below. The date and exact time of collection for each venous blood sample should be documented on the laboratory requisition.

### Pharmacokinetic Sampling Schedule

PK Sample Number	Cycle and Day	Dosing of Abemaciclib	Dosing of NSAIs/Fulvestrant	Sampling Time for PK from Blood <sup>a</sup>
1	C1D1	X	X	2 to 4 hrs after blinded study drug dosed in clinic
2	C2D1	X <sup>b</sup>	X	Cohort A: Upon arrival at site (ie, at least 4 hrs after taking NSAID and blinded study drug doses at home) Or Cohort B: Upon arrival at site but prior to fulvestrant dose (ie, at least 4 hrs after taking blinded study drug dose at home)
3	C2D1			3 ± 0.5 hrs after PK Sample Number 2 (ie, at least 7 ± 0.5 hrs after taking blinded study drug dose at home)
4	C3D1	X	X	Prior to blinded study drug dose
5	C4D1	X	X	Prior to blinded study drug dose

Abbreviations: C = cycle; D = day; hr = hour; PK = pharmacokinetic; NSAID = nonsteroidal aromatase inhibitor.

- <sup>a</sup> Samples of approximately 4 mL of whole blood will be drawn. After obtaining plasma, site personnel will aliquot samples into 2 approximately equal portions, one for measurement of abemaciclib and its metabolites' concentrations and the other for measurement of NSAID/fulvestrant concentrations. In the event of a dose suspension of blinded study drug due to toxicity at the beginning of a cycle, the PK Sampling Schedule may require adjustment. In these exceptional circumstances, the sponsor should be notified.
- <sup>b</sup> On Cycle 2 Day 1 only, patient should take blinded study drug dose at home at least 4 hours before arrival at site. The time of blinded study drug dose intake must be recorded that day.

---

**Attachment 8. Protocol JPBQ Inducers of CYP3A, Strong Inhibitors of CYP3A, or Substrates of CYPs with Narrow Therapeutic Range**

---

The information in this attachment is provided for guidance to investigators and does not preclude the use of these medications if clinically indicated.

**Inducers of CYP3A**

---

Carbamazepine  
Dexamethasone<sup>a</sup>  
Phenobarbital/phenobarbitone  
Phenytoin  
Rifapentine  
Rifampin  
Rifabutin  
St. John's wort

---

Abbreviation: CYP = cytochrome P450.

<sup>a</sup> Important note: All patients may receive supportive therapy with dexamethasone, preferably  $\leq 7$  days, if clinically indicated.

**Strong inhibitors of CYP3A**

---

Aprepitant  
Ciprofloxacin  
Clarithromycin  
Diltiazem  
Erythromycin  
Fluconazole  
Itraconazole  
Ketoconazole  
Nefazodone  
Verapamil

---

Abbreviations: CYP = cytochrome P450; HIV = human immunodeficiency virus.

**Cytochrome P450 Substrates with Narrow Therapeutic Range**

<b>Cytochrome P450</b>	<b>Substrate</b>
CYP1A2	Theophylline Tizanidine
CYP2C9	Warfarin Phenytoin
CYP2D6	Thioridazine Pimozide
CYP3A	Alfentanil Astemizole Cisapride Cyclosporine Dihydroergotamine Ergotamine Fentanyl Pimozide Quinidine Sirolimus Tacrolimus Terfenidine

Abbreviation: CYP = cytochrome P450.

- <sup>a</sup> Important note: All patients may receive supportive therapy with dexamethasone, preferably  $\leq 7$  days, if clinically indicated. Patients requiring more than 7 days of dexamethasone therapy will not incur a protocol deviation.

---

**Attachment 9. Protocol JPBQ CTCAE 4.03 Diarrhea  
Definition**

---

Diarrhea will be evaluated in this study using the criteria proposed by Common Terminology Criteria for Adverse Events (CTCAE) v4.0 revised: CTCAE 4.03-June 14, 2010: Gastrointestinal disorders.

Gastrointestinal Disorders					
Grade					
Adverse Event	1	2	3	4	5
Diarrhea	Increase of <4 stools per day over baseline; mild increase in ostomy output compared to baseline.	Increase of 4-6 stools per day over baseline; moderate increase in ostomy output compared to baseline	Increase $\geq 7$ stools per day over baseline; incontinence; hospitalization indicated; severe increase in ostomy output compared to baseline; limiting self-care	Life-threatening consequences; urgent intervention indicated	Death
Definition: a disorder characterized by frequent and watery bowel movements					

---

**Attachment 10. Protocol JPBQ Amendment (e) Summary  
A Randomized, Double-Blind, Placebo-  
Controlled, Phase 3 Study to Compare  
NSAI (Anastrozole or Letrozole) plus  
Abemaciclib, a CDK4 and CDK6 Inhibitor,  
or plus Placebo, and to Compare  
Fulvestrant plus Abemaciclib or plus  
Placebo in Postmenopausal Women with  
Hormone Receptor-Positive, HER2-  
Negative Locoregionally Recurrent or  
Metastatic Breast Cancer**

---

### Overview

Protocol I3Y-CR-JPBQ, A Randomized, Double-Blind, Placebo-Controlled, Phase 3 Study to Compare NSAI (Anastrozole or Letrozole) plus Abemaciclib, a CDK4 and CDK6 Inhibitor, or plus Placebo, and to Compare Fulvestrant plus Abemaciclib or plus Placebo in Postmenopausal Women with Hormone Receptor-Positive, HER2-Negative Locoregionally Recurrent or Metastatic Breast Cancer, has been amended. The new protocol is indicated by amendment (e) and will be used to conduct the study in place of any preceding version of the protocol.

The overall changes and rationale for the changes made to this protocol are as follows:

- Remove the wording of forbid crossover in the continued access period.
- Statistical analysis plan was updated regarding final analysis for Cohort A and Cohort B in different scenarios.
- Incorporated safety monitoring language for hepatic conditions, renal function and VTEs.
- In case of under treatment of another effective therapeutic agent, patients need to be discontinued of study drug instead of discontinuation from study.
- Clarified and updated when study drug need to be suspended or reduced.

## Revised Protocol Sections

**Note:** Deletions have been identified by ~~strikethroughs~~.  
Additions have been identified by the use of underline.

### Synopsis

#### Statistical Methods:

...

An interim analysis will be conducted on Cohort A when 119 PFS events have been observed. If positive, an interim of Cohort B will also be conducted on the same cutoff. If patients in Cohort A continue being followed for PFS until final analysis, the final analysis of Cohort B will be conducted at the same time of Cohort A final analysis. If Cohort A stops early at interim due to efficacy, the final analysis of Cohort B may be conducted after approximately 105 PFS events have been observed in Cohort B.

#### Section 4. Abbreviations...

**VTE**                      venous thromboembolic event

#### 7.3.2. Discontinuation of Study Drug(s)

- enrollment in any other clinical trial involving an IP or enrollment in any other type of medical research judged not to be scientifically or medically compatible with this study

If patients discontinue NSAIs/fulvestrant but continue to receive blinded study drug, this will not be considered as discontinuation of study drug.

#### 7.3.3. Discontinuation from the Study

Patients will be discontinued from the study in the following circumstances:

- ~~enrollment in any other clinical trial involving an IP or enrollment in any other type of medical research judged not to be scientifically or medically compatible with this study~~

### 8.1 Summary of Study Design

The primary analysis of the PFS endpoint will occur after approximately 170 PFS events have been observed in Cohort A. An interim analysis will be conducted after approximately 119 PFS events are observed to provide early efficacy information and allow for potential early communication with regulatory agencies.~~allow for early stop of Cohort A due to efficacy~~ (see Section 12.2.6 for details).

The interim analysis of Cohort B will follow the timeline of Cohort A, which. ~~An interim of Cohort B will occur only if the interim of Cohort A turns out to be positive. If patients in Cohort A continue being followed for PFS until final analysis, t~~The final analysis of Cohort B will be conducted at the same time of Cohort A final analysis. If Cohort A stops early at interim due to efficacy, the final analysis of Cohort B may be conducted after approximately 105 PFS events have been observed in Cohort B. (see Section 12.2.14 for details).

For each cohort, ~~a~~All patients will be followed for progression and survival information until death or study completion, whichever occurs first.

...

- Continued Access Period: begins after study completion and ends at the end of trial. During the continued access period, patients on study treatment who continue to experience clinical benefit may continue to receive study treatment (~~except placebo~~) until one of the criteria for discontinuation is met.

### 8.1.1 Study Completion and End of Trial

This study will be considered complete following the last required PFS event from Cohort A ~~or Cohort B~~ (Figure JPBQ.8.2), ~~whichever is longer~~, as determined by Lilly, ~~when all of the required short-term follow-up assessment is completed~~. In case Cohort A stops early at interim due to efficacy and Cohort B continues thereafter, Cohort B will be considered complete following the final analysis of PFS in Cohort B. Investigators will continue to follow the study schedule for all patients until notified by Lilly that study completion has occurred.

### 8.1.2 Continued Access Period

After study completion, all patients who are on study treatment and who are eligible for continued access will be unblinded. Patients receiving study treatment and experiencing ongoing clinical benefit and no undue risks may continue to receive study treatment in the continued access period until one of the criteria for discontinuation is met (see Section 7.3). ~~During the continued access period, placebo will no longer be administered, and crossover will not be permitted.~~ Lilly will notify investigators when the continued access period begins.

Table JPBQ.9.1. Treatment Regimens/Dosing Schedule

Regimen	Period/Cycle	Dose Day
<b>Arm A1</b>		
Abemaciclib	Treatment/28-day cycle	150 mg PO Q12H on Days 1-28
Anastrozole		1 mg PO Q24H on Days 1-28 <sup>a</sup>
or	Treatment/28-day cycle	or
Letrozole		2.5 mg PO Q24H on Days 1-28 <sup>a</sup>
<b>Arm A2<sup>b</sup></b>		
Placebo	Treatment/28-day cycle	PO Q12H on Days 1-28
Anastrozole		1 mg PO Q24H on Days 1-28 <sup>a</sup>
or	Treatment/28-day cycle	or



Letrozole	2.5 mg PO Q24H on Days 1-28 <sup>a</sup>
-----------	--

**Arm B1**

Abemaciclib	Treatment/28-day cycle	150 mg PO Q12H on Days 1-28
Fulvestrant	Treatment/28-day cycle	500 mg IM on Days 1 and 15 of Cycle 1, then Day 1 of Cycle 2 and beyond <sup>εb</sup>

**Arm B2<sup>d</sup>**

Placebo	Treatment/28-day cycle	PO Q12H on Days 1-28
Fulvestrant	Treatment/28-day cycle	500 mg IM on Days 1 and 15 of Cycle 1, then Day 1 of Cycle 2 and beyond <sup>bc</sup>

Abbreviations: IM = intramuscular; NSAID = nonsteroidal aromatase inhibitor; Q12H = once every 12 hours; Q24H = once every 24 hours; PK = pharmacokinetic; PO = orally.

<sup>a</sup> For PK purposes, NSAID should be administered at the same time (or up to 20 minutes after) the first dose of blinded study drug through Cycle 4, Day 1. Subsequently, the interval between administration of blinded study drug and NSAID may be adjusted based on the judgment of the investigator.

<sup>b</sup> For patients in Arm A2 who crossover to Arm A1, the Arm A1 treatment schedule should be followed.

<sup>εb</sup> For PK purposes, fulvestrant should be administered at the same time as (or up to 20 minutes after) the first dose of blinded study drug, except when specified otherwise in the PK Sampling Schedule (Attachment 7) through Cycle 4 Day 1. Subsequently, the interval between administration of blinded study drug and fulvestrant may be adjusted based on the judgment of the investigator.

<sup>d</sup> For patients in Arm B2 who crossover to Arm B1, the Arm B1 treatment schedule should be followed.

Table JPBQ.9.2. Toxicity Dose Adjustments and Delays of Blinded Study Drug for Study JPBQ

Toxicity Type	Toxicity Profile and Severity	Dose Suspension	Dose Reduction
Hematologic Toxicity Section 9.4.1.1.3	Grade 3	Dose <b>MUST</b> be suspended until toxicity resolves to at least Grade 2	Dose <b>MAY</b> be reduced by 1 dose level at investigator's discretion

Hematologic Toxicity Section 9.4.1.1.3	Recurrent Grade 3 within 8 weeks	Dose <b>MUST</b> be suspended until toxicity resolves to at least Grade 2	Dose <b>MUST</b> be reduced by 1 dose level.
Hematologic toxicity: <b>Patient requires administration of blood cell growth factors</b> Sections 9.4.1.1.3 and 9.6.4	Grade 3	Dose <b>MUST</b> be suspended for at least 48 hours after the last dose of blood cell growth factors was administered and until toxicity resolves to at least Grade 2	Dose <b>MUST</b> be reduced by 1 dose level unless already performed for incidence of toxicity that led to the use of growth factor.
Hematologic Toxicity Section	Recurrent Grade 3 within 8 weeks	Dose <b>MUST</b> be suspended until toxicity resolves to at least Grade 2	Dose <b>MUST</b> be reduced by 1 dose level.
Hematologic Toxicity Section 9.4.1.1.3	Grade 4	Dose <b>MUST</b> be suspended until toxicity resolves to at least Grade 2	Dose <b>MUST</b> be reduced by 1 dose level.
Hematologic toxicity: <b>If patient requires administration of blood cell growth factors</b> Sections 9.4.1.1.3 and 9.6.4	Regardless of severity (Use growth factors according to ASCO Guidelines)	Dose <b>MUST</b> be suspended for at least 48 hours after the last dose of blood cell growth factors was administered and until toxicity resolves to at least Grade 2.	Dose <b>MUST</b> be reduced by 1 dose level unless already performed for incidence of toxicity that led to the use of growth factor.
Nonhematologic Toxicity <sup>b</sup> (except diarrhea and ALT increased) Section 9.4.1.1.4	Persistent or recurrent Grade 2 that does not resolve with maximal supportive measures within 7 days to baseline or Grade 1	Dose <del>MAY</del> <b>MUST</b> be suspended until toxicity resolves to either baseline or Grade 1.	Dose <del>MAY</del> <b>MUST</b> be reduced by 1 dose level <del>at investigator's discretion.</del>
Nonhematologic Toxicity Section 9.4.1.1.4	Grade 3 or 4	Dose <b>MUST</b> be suspended until toxicity resolves to either baseline or Grade 1	Dose <b>MUST</b> be reduced by 1 dose level.
Diarrhea Sections 9.4.1.1.4.1 and 9.6.5	<u>Grade 2 that does not resolve within 24 hours to at least Grade 1</u> Requires	Dose <b>MUST</b> be suspended until toxicity resolves to at least Grade 1.	Dose <del>MUST</del> <b>reduction is NOT required</b> by 1 dose level.
Diarrhea Sections 9.4.1.1.4.1 and 9.6.5	Persistent or recurrent Grade 2 that does not resolve with maximal supportive measures, or any Grade of diarrhea that	Dose <del>SHOULD</del> <b>MUST</b> be suspended until toxicity resolves to at least Grade 1.	Dose <del>MAY</del> <b>MUST</b> be reduced by 1 dose level <del>at investigator's discretion.</del>
Diarrhea Sections 9.4.1.1.4.1 and 9.6.5	<del>Grade 3 or 4</del> Diarrhea recurs despite maximal supportive measures after resuming same dose level after initial	Dose <b>MUST</b> be suspended until toxicity resolves to at least Grade 1.	Dose <b>MUST</b> be reduced by 1 dose level.
ALT Increased (Sections 9.4.1.1.4.2, and 10.3.3.1)	Persistent or recurrent <sup>a</sup> Grade 2 (>3.0-5.0×ULN), or	Dose <b>MUST</b> be suspended until toxicity resolves to baseline or Grade 1.	Dose <b>MUST</b> be reduced by 1 dose level.

ALT Increased (Sections 9.4.1.1.4.2 and 10.3.3.1)	Grade 4 (>20.0×ULN)	Blinded study drug <b>MUST</b> be discontinued.	Blinded study drug <b>MUST</b> be discontinued.
ALT Increased with increased total bilirubin, in the absence of cholestasis (Sections 9.4.1.1.4.2)	Grade 3 increased ALT (>5.0 x ULN) with total bilirubin >2 x ULN	Blinded study drug <b>MUST</b> be discontinued	Blinded study drug <b>MUST</b> be discontinued

Abbreviation: ALT = alanine transaminase; ASCO = American Society of Clinical Oncology.

Note: -MAY = per the investigator’s clinical judgment; SHOULD = not mandatory but highly recommended; MUST = mandatory.

a Determination of persistent events will be at the discretion of the investigator. Recurrent toxicity refers to the same event occurring within the next 8 weeks (as measured from the stop date of the preceding event). As a general guidance, based on the risk/benefit balance assessment per the investigator, for a patient who experiences a new episode of Grade 3 hematological toxicity after more than 8 weeks following the last episode of same Grade 3 hematological toxicity, the investigator may consider resuming the patient on the same drug dose should the patient satisfy the following conditions:

- shows stable hematological counts (Grade ≤2) during that timeframe
- has absence of any signs or risk of infection
- is benefiting from study treatment

b Additional guidance for renal and hepatic monitoring is in Sections 10.3.3.1 and 10.3.3.2

c Grade 3 ALT increased is a trigger for additional assessments and possibly hepatic monitoring. See Section 10.3.1.1 ~~10.3.1.1~~ for additional guidance for hepatic monitoring

**9.4.1.1.3. Hematologic Toxicity**

If the patient experiences a recurrent episode of Grade 3 hematologic toxicity within 8 weeks, then dosing must be suspended (until the toxicity resolves to at least Grade 2) and the dose of blinded study must be reduced by 1 dose level as outline in Table JPBQ.9.3

Recurrent toxicity refers to the same event occurring within the next 8 weeks (as measured from the stop date of the preceding event). As a general guidance, based on the risk/benefit balance assessment per the investigator, for a patient who experiences a new episode of Grade 3 hematological toxicity after more than 8 weeks following the last episode of same Grade 3 hematological toxicity, the investigator may consider resuming the patient on the same drug dose should the patient satisfy the following conditions:

- The patient showed stable hematological counts (Grade ≤2) during that timeframe

- In the absence of any signs or risk of infection
- The patient is benefiting from study treatment

If a patient ~~experiences Grade 3 hematologic toxicity and~~ requires administration of blood cell growth factors

#### **9.4.1.1.4. Nonhematologic Toxicity**

If a patient experiences persistent or recurrent Grade 2 nonhematologic toxicity (except diarrhea; see Section 9.4.1.1.4.1 ALT increased, refer to Section 9.4.1.1.4.2 ) possibly related to blinded study drug that does not resolve with maximal supportive measures within 7 days to either baseline or Grade 1, then dosing ~~may~~must be suspended (until the toxicity resolves to either baseline or at least Grade 1) and the dose of blinded study drug ~~may~~must be reduced by 1 dose level as outlined in Table JPBQ.9.3.

##### **9.4.1.1.4.1. Diarrhea**

A patient experiencing diarrhea requiring hospitalization (irrespective of grade, that is, requiring intravenous [IV] rehydration) or severe diarrhea (Grade 3 or 4; see Attachment 9) must have study treatment suspended (until the toxicity resolves to at least Grade 1) and must have the blinded study drug dose reduced by 1 dose level ~~as outlined in Table JPBQ.9.3.~~ Table JPBQ.9.3

If a patient experiences persistent or recurrent diarrhea that does not resolve with maximal supportive measures (refer to Section 9.6.5) within 24 hours to at least Grade 1, then study treatment ~~should~~must be suspended (until the toxicity resolves to at least Grade 1) and the dose of blinded study drug ~~may~~must be reduced by 1 dose level as outlined in Table JPBQ.9.3 ~~at the discretion of the investigator. If the same dose level was resumed and diarrhea recurs despite maximal supportive measures, the dose of blinded study drug must be reduced by 1 dose level as outlined in Table JPBQ.9.3.~~

##### **9.4.1.1.4.2. Hepatic Toxicity**

Does modifications and management for increased ALT are provided in Table JPBQ 9.2. For persistent or recurrent Grade 2 ALT increased that does not resolve with maximal supportive measures within 7 days to baseline or Grade 1, or Grade 3 ALT increased, blinded study drug must be suspended until the toxicity has resolved to at least Grade 1 and the dose must be reduced by 1 dose level. Discontinue blinded study drug for Grade 3 increased ALT (>5.0 x ULN) with total bilirubin >2 x ULN, in the absence of cholestasis. For Grade 4 ALT increased, the patient must be discontinued from blinded study drug. Refer to Section 9.4.1.1.4.2 for additional hepatic monitoring guidance.

### **10.3.1 Adverse Events**

The investigator will record all AE/SAE information in the CRF. Investigators will be instructed to report to Lilly or its designee their assessment of the potential relatedness of each AE to protocol procedure and/or study drugs via eCRF.

#### **10.3.1.1. Serious Adverse Events**

All AEs occurring after signing the ICF are recorded in the eCRF and assessed for serious criteria. An SAE is any AE from this study that results in 1 of the following outcomes:

### **10.3.3. Safety Monitoring**

- AEs
- ~~If a patient experiences elevated ALT  $\geq 5 \times$  ULN and elevated total bilirubin  $\geq 2 \times$  ULN, clinical and laboratory monitoring should be initiated by the investigator. For patients entering the study with ALT  $\geq 3 \times$  ULN, monitoring should be triggered at ALT  $\geq 2 \times$  baseline.~~
- ~~Details for hepatic monitoring depend upon the severity and persistence of observed laboratory test abnormalities. To ensure patient safety and comply with regulatory guidance, the investigator is to consult with the Lilly CRP regarding collection of specific recommended clinical information and follow-up laboratory tests (see Attachment 3).~~

#### **10.3.3.1. Special Hepatic Safety Data Collection**

If a study patient experiences elevated ALT  $\geq 5 \times$  ULN and elevated total bilirubin (TBL)  $\geq 2 \times$  ULN, or ALT  $> 8 \times$  ULN for patients with underlying baseline hepatic metastases, liver tests (Attachment 4), including ALT, AST, TBL, direct bilirubin, gamma glutamyl transferase (GGT), and creatine phosphokinase (CPK), should be repeated within 3 to 5 days to confirm the abnormality and to determine if it is increasing or decreasing. If the abnormality persists or worsens, clinical and laboratory monitoring should be initiated by the investigator, based on the hepatic monitoring tests (Attachment 3) and in consultation with the Lilly CRP. Monitoring of ALT, AST, and TBL should continue until levels normalize or return to approximate baseline levels. Additional diagnostic testing should be considered to rule out cause of increased liver enzymes per the investigator's discretion.

Hepatic monitoring tests (Attachment 3) should be collected in the event that 1 or more of the following conditions is met for the patient during the course of the study:

- ALT  $\geq 5 \times$  ULN and TBL  $\geq 2 \times$  ULN
- ALT  $> 8 \times$  ULN for patients with underlying hepatic metastasis
- discontinuation from study treatment due to a hepatic event or an abnormality of liver tests

#### **10.3.3.2. Renal Function**

Abemaciclib has been shown to increase serum creatinine due to inhibition of renal tubular secretion of creatinine without affecting cystatin C-calculated glomerular filtration rate. Increases in serum creatinine occurred within the first 2 weeks of treatment, remained stable through the treatment period, and were reversible upon treatment discontinuation. If deterioration of renal function is suspected, serum creatinine should not be the only measure used to assess a patient's renal function.

Dose adjustment (omission, reduction, or discontinuation) should not solely be based on interpretation of serum creatinine values because these may not reflect renal function. If

deterioration of renal function is suspected per the investigator's clinical assessment, dose alteration should follow the protocol guidance for non-hematological toxicities (Table JPBO 9.2).

### **10.3.3.3. Venous Thromboembolic Events**

In the randomized Phase 3 studies in breast cancer patients who received abemaciclib in combination with endocrine therapy, there was a greater number of patients who experienced VTEs in the abemaciclib plus endocrine therapy arm than in the placebo plus endocrine therapy arm. The majority of the events were non-serious and were treated with low-molecular-weight heparin. Generally, these events did not result in discontinuation of the study treatment. At this time, the mechanism underlying the association between abemaciclib and the occurrence of VTEs is not known. For suspected or confirmed VTE (eg. deep vein thrombosis or pulmonary embolism), treatment should occur according to usual clinical practice.

### **12.2.1. General Considerations**

Safety analyses will be based on the randomized and treated population (ie, Safety Population), defined as all randomized patients receiving at least 1 dose of blinded study drug or NSAI/fulvestrant-control.

### **12.2.6. Primary Outcome and Methodology**

The purpose of the interim analysis is to provide early efficacy information and allow for potential early communication with regulatory agencies ~~stop the study early for positive efficacy.~~

### **12.2.7.1 Progression-Free Survival in Cohort B**

If patients in Cohort A continue being followed for PFS until final analysis, the final analysis of Cohort B will be conducted at the same time of Cohort A final analysis. If Cohort A stops early at interim due to efficacy, the final analysis of Cohort B may be conducted after approximately 105 PFS events have been observed in Cohort B (that is, an approximately 30% censoring rate) ~~The final analysis of Cohort B will be conducted together with the final analysis of Cohort A.~~

### **12.2.13. Subgroup Analyses**

Subgroup analyses of PFS will be performed for potential prognostic subgroup variables within each cohort, including:

- All baseline stratification factors
- NSAI received for Cohort A while on study (letrozole vs. anastrozole)
- Study entry disease status ~~Disease setting~~ (de novo metastatic vs. recurrent metastatic vs. locoregionally recurrent)

### **12.2.14. Interim Analysis and Other Planned Analyses**

An interim analysis on Cohort A will be conducted by the DMC after approximately 11970% of the required PFS events have been observed. The interim analysis will be conducted to provide early efficacy information and could potentially result in early communication with regulatory

agencies. The O'Brien Fleming alpha spending function (Lan and DeMets 1983) will be used to preserve the overall type I error. If the analysis of PFS is significant using the cutoff described in Section 12.2.6, the DMC will be instructed to engage the SMD, who may subsequently convene an IRC to propose actions based upon the DMC's recommendation. All patients will continue follow-up for PFS until study completion, and will remain blinded for the duration of the study unless emergency unblinding (Section 9.5.2) are met. If Cohort A show early efficacy at interim, ~~enrollment in this cohort will be terminated and the sponsor may consider early stop, unblinding and crossover for this cohort~~ subjects that randomized to the control group will not be permitted to cross over to the experimental group. In addition, ~~patients will remain blinded for the duration of the study unless emergency unblinding (Section 9.5.2) are met.~~; however, regulatory agencies will be consulted before any action is taken ~~All patients will continue follow-up for PFS until study completion.~~

...

If statistical significance is not declared at the interim, ~~a~~ A final analysis of Cohort A will be conducted with about 170 PFS events, ~~regardless of the result of the Cohort A interim.~~

The interim analysis of Cohort B is triggered only if statistical significance is declared at the Cohort A interim analysis. No DMC is required for the analysis of Cohort B. The analysis will provide both safety and efficacy information of Cohort B and could potentially result in early communication with regulatory agencies, including consultation of potential decisions regarding early stop, unblinding and crossover before any action is taken.

In the case of early stop and crossover for Cohort A or Cohort B after the interim analysis, Lilly will notify investigators when the crossover begins.

If patients in Cohort A continue being followed for PFS until final analysis, the final analysis of Cohort B will be conducted at the same time of Cohort A final analysis. If Cohort A stops early at interim due to efficacy, the final analysis of Cohort B may be conducted after approximately 105 PFS events have been observed in Cohort B ~~The final analysis is planned at the same time of Cohort A final. The sponsor has no intent to stop Cohort B; all patients will continue follow-up for PFS until study completion.~~

## **Attachment 8. Protocol JPBQ Inducers of CYP3A, Strong Inhibitors of CYP3A, or Substrates of CYPs with Narrow Therapeutic Range**

### **Strong inhibitors of CYP3A**

---

All HIV protease inhibitors

Aprepitant

Ciprofloxacin

Clarithromycin

Diltiazem

Erythromycin

Fluconazole

Itraconazole

Ketoconazole

Nefazodone

Verapamil

---

Abbreviations: CYP = cytochrome P450; HIV = human immunodeficiency virus.**Cytochrome P450 Substrates with Narrow Therapeutic Range**

<b>Cytochrome P450</b>	<b>Substrate</b>
CYP1A2	Theophylline Tizanidine
CYP2C8	Paclitaxel



Leo Document ID = 6776d7fb-f6f9-4c46-857a-08ad09e38232

Approver: PPD  
Approval Date & Time: 14-May-2019 09:29:39 GMT  
Signature meaning: Approved

Approver: PPD  
Approval Date & Time: 14-May-2019 11:32:41 GMT  
Signature meaning: Approved